

ACER

OPERATION MANUAL

Vertical Turret Milling Machine

Model: e-mill 3VS & 3VSII, e-mill 3VK

e-mill 3VKH, e-mill 5VK, e-mill 6VK

w/ Toshiba & Fuji Inverter

Taiwan: Ya-Gin Machine Tool Manufacturing Inc.

No. 101, 506 Lane, Seng-Tso Road,

Seng Karng District, Taichung City, Taiwan

Tel: 886-4-2520-4120 Fax: 886-4-2520-4123

CA: Springwood Industrial, Inc.

2320 E. Valencia Drive

Fullerton, CA 92831

Tel: 714-871-5558 Fax: 714-871-5554

NJ: Klim Industrial, Inc.

244 N. Randolphville Rd.

Piscataway, NJ 08854

Tel: 732-752-9100 Fax: 732-752-9101

Revised: 4/18/19

ATTENTION

We are grateful that you have chosen our product! We are confident that our Milling Machines will satisfy your expectations with their many outstanding features, such as: rigidity, high accuracy, versatility, etc. In order to achieve the highest possible performance from our machines, we expect all operators and those concerned with maintenance to **READ THIS MANUAL CAREFULLY BEFORE STARTING**. This manual explains machine operation, inspection, maintenance, lubrication and set up procedures. We hope all operators will consult this Manual for their safety and the machine's.

CONTENT

	Page#
1. SAFETY INSTRUCTIONS	5
1-1. General Safety Instructions For Operating The Machine	5
1-1-1 Safety instructions for work holding	7
1-2. Maintenance Safety Instruction	8
1-3. Installation Precautions	8
1-3-1 Grounding	9
1-3-2 Environmental conditions	10
1-4. Safety Precaution	10
1-4-1 Before powering on the machine	12
1-4-2 Routine inspections	12
1-4-3 Warm-up	13
1-4-4 Preparations	13
1-4-5 Operation	14
1-4-6 Noise level	14
1-4-7 To interrupt machine	15
1-4-8 Completing a job	15
1-4-9 Safety devices	16
1-4-10 Maintenance operation preparations	16
1-4-11 Maintenance operation	16
1-4-12 Unit operation is begun after maintenance	17
1-5. Warning Signs On The Machine	17
2. SPECIFICATION	20
2-1. Machine Specification	20
2-2. Milling Head Specification	30
2-3. Features & Description of Machines	31
3. UNCRATING & CLEANING	34
4. INSTALLATION	34
4-1. Lifting Machine	35
4-2. Solid Foundation	38
4-3. Leveling Machine	42
4-4. Handles	42
4-5. Connecting Power Supply	42
4-6. Wiring Diagram	44
A. Regular Circuit Diagram for 3VS, 3VSII, 3VK, 3VKH, 5VK	44
B. Regular Circuit Diagram for 6VK	52
C. UL Electric Diagram for 3VS, 3VSII, 3VK, 3VKH, 5VK	60
D. UL Electric Diagram for 6VK	65

	Page#
E. Electrical Part List with Part Number Listed	73
F. Amendment of UL Part List (File No: TR14101501; Date: 4/11/19)	76
4-7. Alignment of Head	78
5. LUBRICATION	79
5-1. Lubrication System of e-mill 3VS and 3VSII	79
5-2. Lubrication System of e-mill 3VK	80
5-3. Lubrication System of e-mill 3VKH and 5VK	81
5-4. Lubrication System of e-mill 6VK	82
5-5. Lubrication Schedule for All e-mills	83
5-6. MSDS for Lubricant in Lubrication Pump	84
6. OPERATION	91
6-1. Nomenclature	93
6-2. Draw Bar	95
6-3. Spindle Brake	95
6-4. Forward-Reverse Switch	95
6-5. Hi-Neutral-Lo Lever	95
6-6. Power Feed Engagement Crank	96
6-7. Quill Feed Selector	96
6-8. Feed Reverse Knob	96
6-9. Manual Feed Handwheel	96
6-10. Feed Control Lever	97
6-11. Quill Feed Handle	97
6-12. Quill Stop Knob	97
6-13. Micrometer Adjusting Nut	97
6-14. Quill Lock	97
6-15. Ram Position	98
6-16. Clamping Table, Saddle and Knee	98
6-17. Operation Recommendations	100
6-18. Safety Accessories for All Models	102
7. MAINTENANCE	103
7-1. Adjustment of Table Gib	103
7-2. Adjustment of Saddle and Knee Gibs	103
7-3. Removing Table & Saddle	104
7-4. Leadscrew Backlash Adjustment	104
7-5. Removing the Motor	105
7-6. Changing the Vari-drive Belt—the V Belt	106
7-7. Changing Timing Belt	106
7-8. Returning Spring Replacement	107
7-9. Recommended Spare Part List	108
7-10. Recommended Maintenance Schedule	112

	Page#
7-10-1. Daily maintenance	112
7-10-2. Weekly maintenance	112
7-10-3. Six month maintenance	112
7-10-4. Yearly maintenance	112
7-10-5. Points to watch on doing maintenance	113
7-11. Tables for Material Cutting Information	114
8. MECHANICAL DRAWING & PARTS BREAKDOWN LIST	116
8-1 3HP (Milling Head)	117
8-2. 3HP Head Top Housing	127
8-3. 3HP Head Back Gear	131
8-4. 5HP (Milling Head) Hand Feed Ass'y	137
8-5. 5HP (Milling Head) Spindle Ass'y	141
8-6. 5HP (Milling Head) Auto Feed Ass'y	143
8-7. 5HP e-mill Head Top Housing	149
8-8. 5HP e-mill Head Back Gear	153
8-9. 3VS & 3VSII Basic Machine	157
8-10. 3VK Basic Machine	165
8-11. 3VKH Basic Machine	173
8-12. 5VK Basic Machine	181
8-13. 6VK Basic Machine	189
8-14. 3VS, 3VSII, 3VK, 3VKH & 5VK Leadscrew Assembly	195
8-15. 6VK Leadscrew Assembly	197
8-16. Electric Cabinet	201
8-17. Safety Accessories for All Models	202

1. SAFETY INSTRUCTIONS

WARNING

Do not install, operate or service this machine until:

- 1) You have read and understand the safety instructions on the pages that follow.
- 2) You have read and understand the operator's manual, especially knowing the function and location of all machine controls, and read manuals on all relative accessories.
- 3) You have read and understand all safety and instruction plates attached to the machine and its relative accessories.
- 4) Prior to install or services the machine, please read and understand the maintenance manual.
- 5) To service the machine, it must be done only by competent and trained personnel.

NOTICE: The following safety instructions are general recommendations for most common operations on a milling machine.

Additional safety measures may be required for your particular application. Therefore, manufacturer makes no warranty or representation as the absolute correctness of sufficiency of the instructions.

1-1. General Safety Instructions For Operating The Machine

- 1) The best defense against injuries on a milling machine is to be alert. Never initiate a machine function unless you completely understand what the function will cause the machine to do.
- 2) Never operate the machine with any cover and shield opened or removed.
- 3) Never reach into the work area when the spindle is rotating or if the machine is still in running mode.
- 4) The functions of the machine make it impossible to eliminate all dangerous area. Be particularly aware of the following cautious points:
 - * Spindle rotation
 - * Electric cabinet and power source
 - * Table and saddle movement

- 5) Keep the machine and area around it clean and well lighted. Never allow chips, coolant or oil to remain on the floor. Do not leave loose objects on and around the machine.
- 6) Clothing :
 - * Wear safety glasses with eye shields at all times. Protect your eyes. Never use a compressed air hose to remove chips from a machine.
 - * Never wear loose fitting clothing. Remove all jewelry (rings, watches, necklaces...etc.) since they can be trapped in moving parts of the machine.
 - * Gloves are easily trapped by moving parts. Take them off before turning the machine on.
 - * Always wear safety shoes with steel toes and oil-resistant soles.
 - * Wear a safety helmet when working near overhead hazards.
 - * If operator has long hair, the hair should always be tucked under a cap or tied back up.
- 7) Milling machine are designed to be run by one person. Persons other than the designated operator should stay out of the machine area during the operation.
- 8) Take care, not to bump or accidentally touch the machine control. Doing so can initiate an unintended machine movement which could cause an injury or a wreck.
- 9) Do not paint, alter, deface or remove any warning plates from the machine.
- 10) Report any loose, worn or broken parts to your supervisor. The same action should be taken if any unusual noise or machine action occurs.
- 11) Never operate the machine after taking strong medication, using non-prescription drugs, or consuming alcoholic beverages. Persons with illness, which might cause dizziness or fainting, should never operate this machine.
- 13) The electric components are protected from normal moisture resulting from humidity use of water base soluble coolant, etc. Do not, however, use water hose to clean the machine or the area around it.
- 14) Never touch a machine control device or electrical component when your hand is wet. Keep flammable liquids and materials away from the work area and chips.
- 15) Never clean up chips while the machine is running or is in automatic mode.
- 16) Do not file work pieces while spindle is still rotating under power.
- 17) At the end of the work day the machine should be placed in “power off” mode.
- 18) When restarting a machine after it has been shut down, please always assume it has been tampered with. Recheck all phases of the job as though you were running the first piece.
- 19) Never switch-on spindle until hands, feet, and body are well clear of the work area.

20) Coolant and oil can make surfaces on the machine slippery. They can also present an electrical hazard if the machine has power on. For these reasons, please do not stand on any part of the machine at any time.

1-1-1 Safety instructions for work holding

- 1) Never run a job on this machine until you are 100% sure the work piece is being held in such a manner as withstand the centrifugal force from rotation and cutting forces of the tooling. If there is any doubt, whatsoever, please consult with your supervisor.
- 2) A vise is the most common work holding device used on this machine. Some of the factors affecting the holding device on this machine.

The factors which affect the holding ability of a vise are:

- * Clamping force of the jaws on the vise
- * Rotational speed of the spindle
- * Type of jaw surface (serrated, smooth, etc.)
- * Area of vise holding and configuration of the work piece...shape, weight and balance.
- * Vise's weight and location

- 3) With air or hydraulic actuated power vise (optional accessory), make sure the jaws are gripping the work securely before they reach the end of their travel. When using a power vise, please check the hydraulic or air pressure before every operation. Low air pressure will diminish jaw-gripping force, which may allow the work piece to fly out of the jaws. Excessive pressure can also damage a power vise, which could cause a loss of jaw force. The gripping force of a power vise can be diminished as much as 50% because of lacking of lubrication or periodic cleaning. Components of a vise are subject to wear and damage which also can lessen gripping force. Oil the vise at the beginning of every shift. Please use only the vise manufacturer's recommended lubricant.

A. A weekly examination of the condition of the vise should be made. This examination should include the measurement of jaw clamping force with a jaw-force gage to insure that the vise is functioning as it is intended.

B. Refer to manufacturer's manual for vise and cylinder for any other maintenance requirements. As the cutter's R.P.M. increase the gripping force of the jaws on the vise decreases. The larger the vise opening the more loss becomes. Various types of vise's jaws are serrated contact surfaces on work piece. Improper usage could cause serious injury or death. Remember-vise gripping a work piece safely involves many variables. If you have the slightest doubt regarding the safety of your set-up for a job, please consult with your supervisor.

- 4) Never operate spindle-mounted accessories over their rated speed. If the cutting tool or accessory is not supplied by the original maker, please verify the safety operating speed with the manufacturer.

- 5) Always be sure the tool holder or accessory is located correctly on the spindle taper and it is securely pulled to the face of the spindle.
- 6) Be sure any item bolted or clamped to a vise or fixture is securely fastened before starting the spindle.
- 7) Proper lifting equipment should be used for heavy vises, fixtures, and work pieces.
- 8) Always be aware of that closing vise's jaws may trap fingers or hands.
- 9) The same safety instructions that apply to power vises also apply to manual operated vises. The following additional precautions should be taken when using a manual vise :
 - A. Always use spring-loaded, self-ejecting type safety wrenches.
 - B. Never put an extension bar on a vise wrench or hit with hammer.
 - C. Always slightly tap the workpiece after clamping with the jaws. This is done to make sure workpiece is securely tightened to the vise. Without confirming the tightness, the workpiece may fly out of the vise if the cutting force is too greater!
- 10) If a work piece is extended from the vise a distance of 3 to 4 times of its capacity, without being supported by other means, poor cutting finish will normally occur. Under no circumstances extend an unsupported workpiece more than this amount without supporting with other devices. Doing so can cause the part to bend or break or flying out!

1-2. Maintenance Safety Instruction

WARNING

High voltage is used to power the machine; only authorized electricians should service any electrical component failure. Disconnect main power and lock it in off position before attempting any repair. Tag disconnect switch "DO NOT START"

- 1) Read and understand safety instructions for machine operation before servicing this machine.
- 2) Know all points where high voltages are present on this machine and in electrical boxes.
- 3) Residual voltages can exist in electrical cabinets for a period of time after power has been turned off. Check any component inside cabinet with a voltmeter before touching.

1-3. Installation Precautions

To ensure the safe operation of the milling machine, note the following during installation.

Wiring

- 1) Be sure to use electrical conductors with performance ratings equivalent or superior to those described in the Maintenance Manual.
- 2) Do not connect to the same power distribution panel that is intended for devices, which can cause line noise, such as, welders and high frequency quenching machines.
- 3) Arrange for a qualified electrician to connect the power lines.

1-3-1. Grounding

Use a grounding wire with a cross section of more than 14 mm and a resistance to ground less than 100 ohms.

This wire size should be greater than AWB (American Wire Gauge) No. 5 and SWG (British Legal Standard Wire Gauge) No.6.

Generally, the milling machine should be ground to a separate grounding rod. If an independent ground cannot be provided for the machine, prepare the ground connection as follow:

- 1) Connect a single conductor to its grounding terminal. This will avoid possible serious accidents resulting from ground currents, which might otherwise flow thru the milling machine and damage an electrical component or device within the electric cabinet.
- 2) Be careful when using concrete reinforcing rods as grounding points. These reinforcing rods often are used to ground equipment because they usually offer a resistance to ground of less than 100 ohms. In doing so, please make the connections as follow:
 - A. Do not use the same grounding-reinforcing rod or grounding terminal for other devices, since this could lead to line noise such as produced by electric welders and high frequency quenching machine.
 - B. Use a grounding terminal with an adequate electrical performance rating and is durable in usage.
- 3) A separate grounding wire should be used, one whose length is as short as possible.
- 4) Check the resistance to ground by actual measurement. This should measure less than 100 ohms if the single device is connected to its own grounding rod.

Desirable independent grounding:

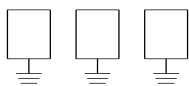

Earth resistance: Less than 100 ohms

Common grounds:

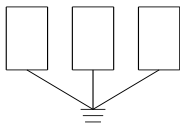

Resistance to ground = 100 the number of devices connected to the grounding (Ω)

Never ground equipment as shown in the lower figure (FORBADE!) :

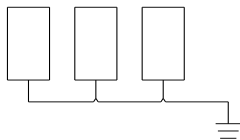

(Wrong)

1-3-2. Environmental conditions

Generally, the machine will be installed at the places with the following conditions. However, these may change over a period of time or in response to seasonal changes.

- 1) Supply voltage : 90% to 110% of nominal supply voltage
- 2) Source frequency : ± 2 hz of nominal frequency
- 3) Ambient temperature : 0°C to 45°C (32°F to 113°F)
- 4) Relative humidity : Less than 80%

Temperature changes should not cause condensation.

- 5) Atmosphere: Free from excessive dust, acid fumes corrosive gases and salt.
- 6) It should be avoided to expose the machine to direct sunlight or heat rays which can change the surrounding temperature.
- 7) Avoid exposing the milling machine to abnormal vibration.

***If it is difficult to observe or meet these conditions, please contact us immediately.

1-4. Safety Precaution

This machine is provided with a number of safety devices to protect operator and equipment from being injured and damaged. Operators should not, however, rely solely upon these safety devices but should operate the machine after fully understanding what special precautions to take by reading the following details thoroughly.

Basic Operating Practices

DANGER

- 1) Some control panels, transformers, motors junction boxes and other parts have high-voltage terminals, these should not be touched or a severe electric shock will be sustained.
- 2) Do not touch a switch with wet hands. This, too, can cause an electric shock.

WARNING

- 1) The emergency stop push-button should be well known so that it can be operated at any time without having to look for it.
- 2) Before replacing a fuse, please power off the machine.
- 3) Provide sufficient working space to avoid hazard. To prevent accidents all floors should be dry and clean.
- 4) Water or oil can make floors slippery and hazardous. To prevent accidents all floors should be dry and clean.
- 5) Before operating switches, please always check that they are the right ones.
- 6) Never touch a switch accidentally.
- 7) Work benches near the machine must be strong enough to prevent accidents. Articles should be prevented from slipping off the bench surface.
- 8) If a job is to be done by two or more persons, coordinating signals should be given at each step of the operation. Unless a signal is given and acknowledged, the next step should not be taken.

CAUTION

- 1) In the event of power failure, turn off the main circuit breaker immediately.
- 2) Use the recommended lubricants and grease or acceptable equivalents.
- 3) Replacement fuses should have the proper current ratings.
- 4) Protect the inverter unit, operation panel (6VK), control panel, etc. from shocks, since this could cause a failure or malfunction.
- 5) Do not change parameters, values and other electrical settings unnecessarily. If such changes are unavoidable, record the values prior to the change so that they can be returned to their original settings if necessary.
- 6) Do not soil, scratch or remove the caution plate. Should it become illegible or missing, please order another caution plate from the supplier. (Please specify the part number shown at the lower right of the plate.)

1-4-1. Before powering on the machine

DANGER

Cables, cords or electric wires whose insulation is damaged can cause current leaks and electric shocks. Before using them on any machine, please check their conditions.

WARNING

- 1) Be sure the instruction manual or the operation manual is fully understood. Every function and operation should be completely clear.
- 2) Use safety shoes, which are not, damageable by oil, safety goggles with side covers, safe clothes and other safety protection.
- 3) Close all electric cabinet doors and table guarding doors (optional) before switching the machine on.

CAUTION

- 1) The power cable from the factory power fuse blocks to the machine's main circuit breaker should have a sufficient cross-sectional area to handle the electric power used.
- 2) Cables which have to lie on the floor must be protected against chips so that short circuit will not occur.
- 3) Each sliding part must be freshly lubricated before starting to operate the machine after unpacking or keeping the machine idle for a long period (several months or more). For initial lubrication and so forth, please keep lubricating oil pump working until oil oozes out from wipers. Contact manufacturer's service station in connection with what procedure should be taken since it depends on the type of machine.
- 4) Oil reservoirs should be filled to indicate levels, check and add oil, if necessary.
- 5) For lubricating points, oil brands and appropriate levels, please see the lubrication chart at later section.
- 6) Switches and handles should operate smoothly.
- 7) Check the coolant level, and add coolant, if necessary (only for 6VK).
- 8) When switching the machine on, connect the factory feeder switch to the machine's circuit breaker, and then turn the power switch to the ON position in this sequence.

1-4-2. Routine inspections

WARNING

When checking V belt tension, please do not get your fingers caught in between the belt and pulley.

CAUTION

- 1) Check lubrication gauge for proper reading (only for 6VK).
- 2) Check spindle, coolant motor (only for 6VK), powerfeeds (only for 6VK) and other parts for abnormal noises.
- 3) Check the motor lubrication and sliding parts for evidence of proper lubrication.
- 4) Check safety covers and safety devices for proper operation (optional accessories).
- 2) Check belt tension. Replace any belt that has become stretched with a fresh matching belt.

1-4-3. Warm-up

- 1) Warm up machine, especially the spindle and lubrication pump by running them for 10 to 20 minutes at about half or one-third the maximum speed indicated on the manual.
- 2) This self-warming-up program should activate each machine's component to operate. At the same time please check their operations' correctness.
- 3) Be particularly careful to warming up the spindle, which can turn up to 4500rpm. If the machine is used for actual machining immediately after spindle start, following a long idle period, sliding parts such as bearings may be worn due to lack of lubrication oil. Also, thermal expansion of the machine's components can jeopardize machining accuracy. To prevent this from happening, always warm the machine up.

1-4-4. Preparations

WARNING

- 1) Tooling should conform to the machine specification and dimensions' types.
- 2) Seriously worn-out tools can cause injuries. Replace all such tools with new ones before intended operation.
- 3) The work area should be adequately lighted to allow for safety checks.
- 4) Tools and other items around the machine or equipment should be stored to ensure good footing and clear aisles.
- 5) Tools or any items must not be place on the head housing, table, ram and other similar places.

CAUTION

- 1) Tool lengths should be within specified tolerances to prevent interference.
- 2) After installing a new tool, please make a trial cut.

1-4-5. Operation

WARNING

- 1) Do not work with long hair that can be caught by the machine. Tie it up at the back and out of the way.
- 2) Do not operate switches with gloves on. This could cause malfunctions, etc.
- 3) Whenever a heavy work piece must be moved, two or more persons should always work together if there is any risk involved.
- 4) Only trained, qualified workers should operate forklift trucks, cranes or similar care should be taken to prevent collisions and damage to surroundings.
- 5) Whenever operating a forklift truck, crane or similar equipment, special care should be taken to prevent collisions and damage to surroundings.
- 6) Wire ropes or slings should be strong enough to handle the loads to be lifted and should conform to the mandatory provision.
- 7) Grip work pieces securely and tightly.
- 8) Stop the machine before adjusting the coolant nozzle at the tip (only on 6VK).
- 9) Never touch a cutting work piece or spindle with bare hands or in any other way.
- 10) While a work piece is cutting, do not wipe it off or remove chips with a cloth or by hand. Always stop the machine first and then use a brush and a sweeper.
- 11) Use a brush to remove chips from the tool tip not with bare hands.
- 12) Stop the machine whenever installing or removing a tool.
- 13) Whenever machining magnesium alloy parts, please wear a protective mask.

CAUTION

- 1) When performing heavy-duty machining, carefully prevent chips from being accumulated since hot chips can cause fire.

1-4-6. Noise level

All machineries make sound when operating. With an assistance from noise dosimeter, the noise level generated when cutting a work piece on ACER mills is recorded at 76.07 dB(A). This is documented as follows,

Equivalent A-weighted Sound pressure level according to EN ISO 3746: 76.07 dB(A)

Uncertainty, K in decibels: 4.0 dB (A) according to EN ISO 4871

The figure quoted is emission levels and are not necessarily safe working levels. Whilst there is a correlation between the emission and exposure levels, this cannot

be used reliably to determine whether or not further precautions are required. Factors that influence the actual level of exposure of the workforce include characteristics of the work room, the other sources of noise, etc. i.e. the number of machines and other adjacent processes. Also the permissible exposure level can vary from country to country, this information, however, will enable the user of the machine to make a better evaluation of the hazard and risk.

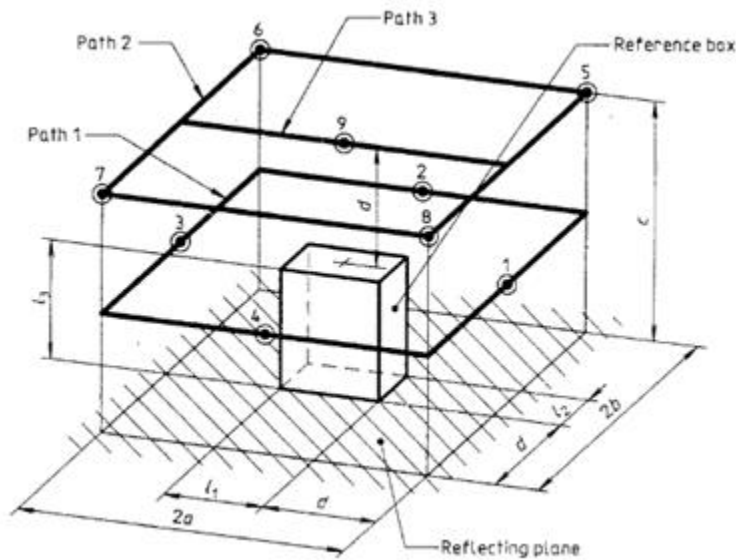

1-4-7. To interrupt machine

WARNING

When leaving the machine temporarily after completing a job, please turn off the power switch on the operation panel and the main circuit breaker.

1-4-8. Completing a job

CAUTION

- 1) Always clean the machine or equipment. Remove and dispose of chips and clean cover, guard and windows, etc.
- 2) Do not clean the machine or equipment before it has been stopped.
- 3) Return each machine component to its initial condition.
- 4) Check wipers for breakage. Replace broken wipers.
- 5) Check coolant, and lubrication oil for contamination. Change them if they are seriously contaminated.
- 6) Check coolant and lubricant levels. Add, if necessary.
- 7) Before leaving the machine at the end of the shift, please turn off the power switch on the operation (only on 6VK) and control panel, machine main circuit breaker, and factory power source breaker in that order.

8) Clean the coolant filter and tank routinely.

1-4-9. Safety devices

- 1) Table guard with doors (optional).
- 2) Chip pan (6VK only).
- 3) Column side guard (optional).
- 4) Travel limit switches (6VK only).
- 5) Emergency stop push buttons.

1-4-10. Maintenance operation preparations

- 1) Do not proceed with any maintenance operation unless being instructed to do by the foreman.
- 2) Replacement parts, consumable such as wipers, oil cups, bearings, oil and grease etc., should be arranged in advance.
- 3) Prepare to record preventive and corrective maintenance operations.

DANGER

- 1) Thoroughly read and understand the safety precautions in the instruction manual.
- 2) Thoroughly read the whole maintenance manual and fully understand the principles, constructions and precautions involved.

1-4-11. Maintenance operation

DANGER

- 1) Those not engaged in the maintenance work should not operate the main circuit breaker or the control power ON switch on the operation or control panel. For this purpose, “Do not touch the switch, maintenance operation in progress” or similar marking should be indicated on such switches and at any other appropriate locations, such indication should be secured by a semi-permanent means in a readable manner.
- 2) With the machine turned on, any maintenance operation can be dangerous. In principle, the main circuit breaker should be turned off throughout the maintenance procedure.

WARNING

- 1) Maintenance operation should be done by qualified personnel. Keep close communication with the responsible person. Do not decide by yourself.

- 2) Over-travel limit and interlock mechanisms including functional parts should not be removed or modified.
- 3) When working at a height level, please use steps or ladders which are maintained and controlled daily for safety.
- 4) Fuses, cables, etc. should be made by qualified manufacturers and then they can be deployed.

1-4-12. Unit operation is begun after maintenance

WARNING

- 1) Arrange tools and items in order around the working area to achieve easy maintenance, and clean working environment. Wipe water and oil off, and provide safe working environments.
- 2) All parts and waste oil should be removed by the operator and placed them far enough away from the machine to be safe.

CAUTION

- 1) The maintenance person should make sure that the machine operation is safe.
- 2) Maintenance and inspection data should be recorded and kept for reference.

1-5. Warning Signs On The Machine

Ya-Gin Machine Tool Manufacturing Inc.-[4 Wire System]	
Model No.	
Serial Number	
Electrical Ratings	
Short Circuit Current Rating	
Largest Motor	
Control Voltage	
Wiring Configuration	
Electrical Drawing No.	
MFG Date	
Enclosure Type	SUITABLE FOR INDOOR USE- NEMA 1
Over Current Protection Provided At Machine Supply Terminals	

Labels are numbered as above!

The label positions for e-mill 3VS, 3VSII, 3VK, 3VKH, and 5VK are indicated on the photo by numbers. (Model machine shown is e-mill 3VK!)



The label positions for e-mill 6VK are indicated on the photo by numbers. (Note: Label #1 for 5VK is also located at the shown position.)

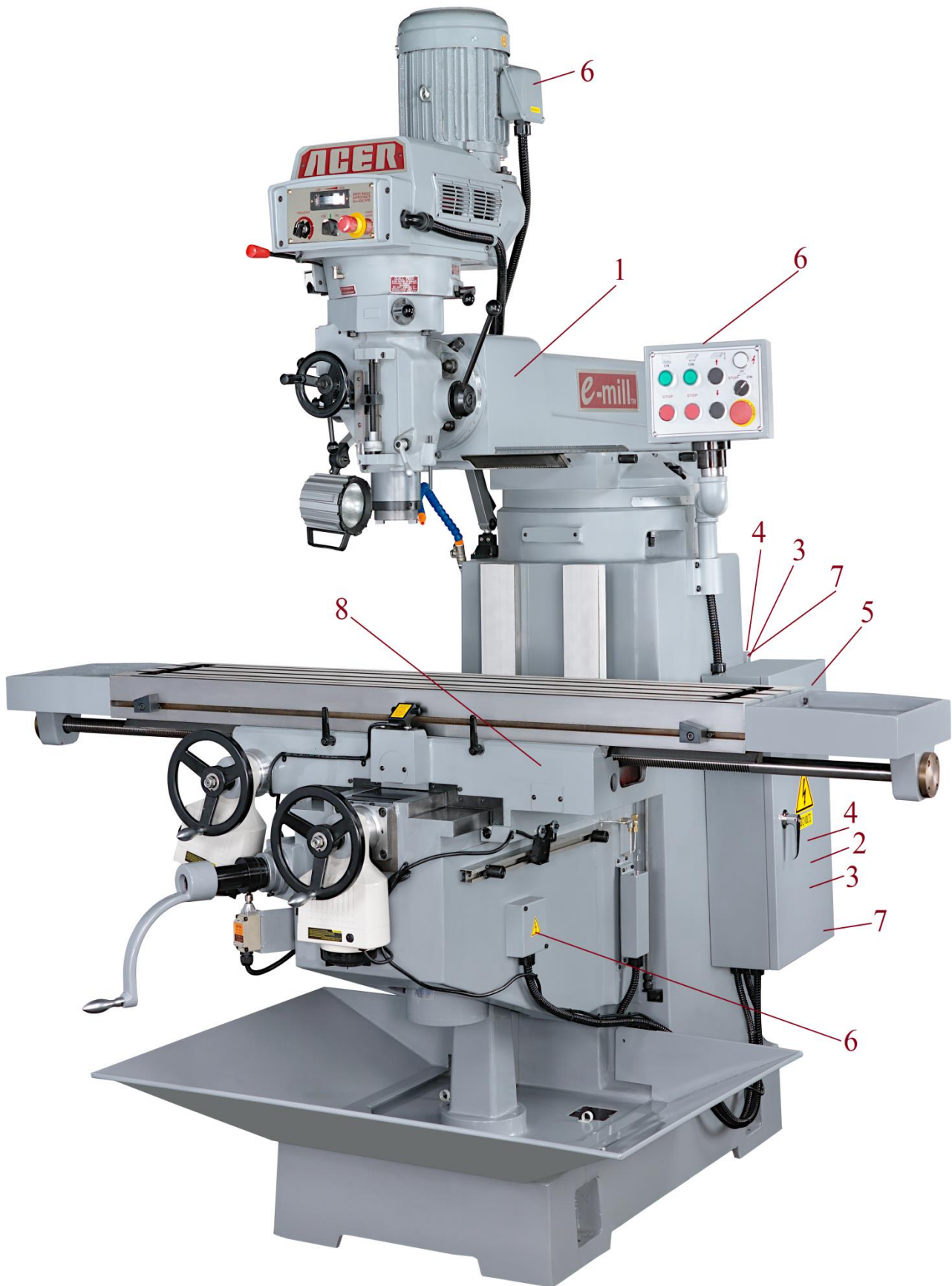

2. SPECIFICATION

2-1 Machine Specification

e-mill 3VS & e-mill 3VSII

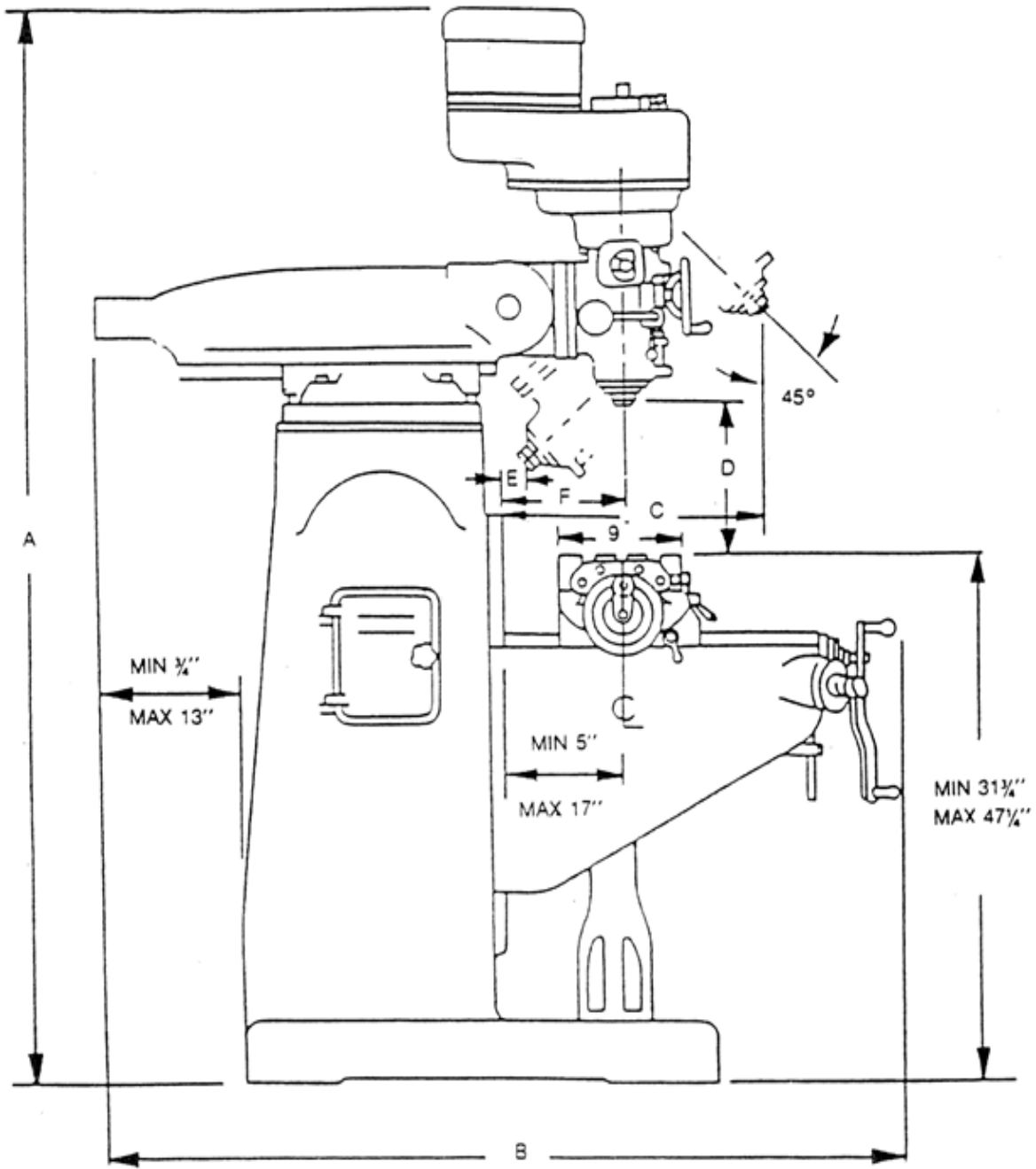

	A	B	C	D	E	F
Min.		51"	8 3/4"	2 1/2"	0	6 3/4"
		1295mm	222mm	64mm		171mm
Max.	88"	63"	20 3/4"	18 1/2"	12"	18 3/4"
	2235mm	1600mm	527mm	470mm	305mm	476mm

Figure 1. Principal Dimension of 3VS & 3VSII

E-MILL 3VS, 3VSII MACHINE SPECIFICATIONS:

Range

Table Travel (X-axis)	42" Table: 24"/ 610mm	49" Table: 28"/ 711mm
Saddle Travel (Y-axis)	12 in. (305mm)	
Quill Travel	5 in. (127mm)	
Knee Travel (Z-axis manual)	16 in. (406mm)	
Ram Travel	12 in. (305mm)	
Throat Distance (min.)	4 1/4 in. (171mm)	
Throat Distance (max.)	28 1/4 in. (476mm)	
Table to Spindle Nose Gage line (min.)	1 in. (25.4mm)	
Max. Weight of Workpiece	750 lbs. (340 kgs.)	

Table

Overall Sizes	9 x 42 in. (229 x 1067mm)	9 x 49 in. (229 x 1245mm)
T-Slots	3 on 2 1/2 in. (64mm) centers	
T-Slot Size	5/8 in. (16mm)	
Height above floor (max.)	48 5/8 in. (1235mm)	

Milling

Feed Rate (Power Optional) Please see Chart

Space and Weight

Floor Area	7 x 10 ft. (2.1 x 3.1m)	
Height	87 in. (2210mm)	
Net Weight	2330 lbs. (1060kgs)	2380 lbs. (1080kgs)
Shipping Weight	2530 lbs. (1150kgs)	2580 lbs. (1173kgs)

Power

Electrical Supply – 60/50 Hz. 3 phase 220/230/380/415/440/460/575V

Color

Standard Machine Gray/ACER White with Burgundy Stripes

e-mill 3VK

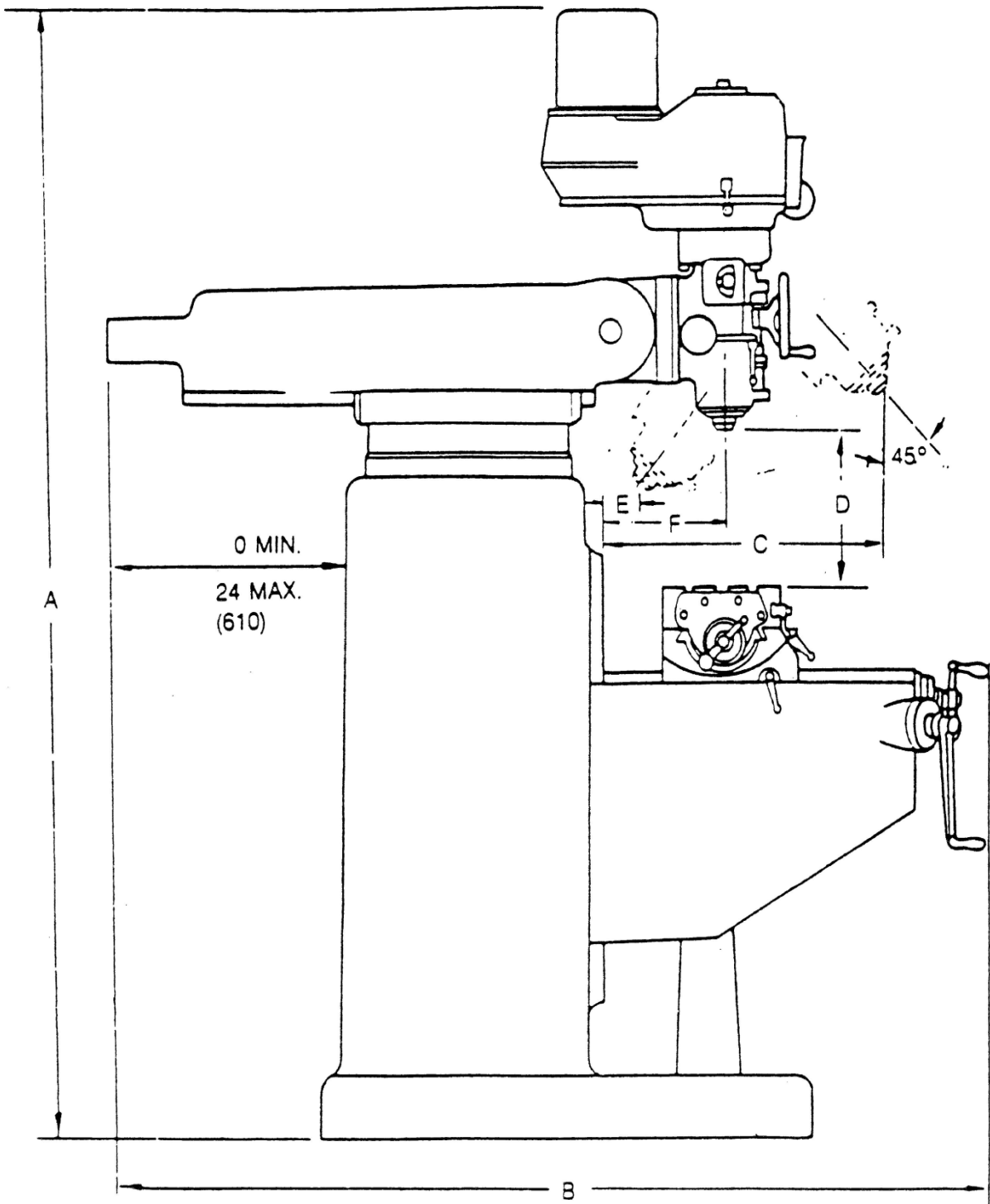

	A	B	C	D	E	F
Min.		56"	11 1/4"	2 1/2"	1	4"
		1422mm	285mm	64mm		102mm
Max.	88"	78"	35 1/4"	18 1/2"	18"	27"
	2235mm	1981mm	895mm	470mm	458mm	686mm

Figure 2. Principal Dimension of 3VK

E-MILL 3VK MACHINE SPECIFICATIONS:

Range

Table Travel (X-axis)	50" Table: 28"/ 711mm
Saddle Travel (Y-axis)	16 in. (406mm)
Quill Travel	5 in. (127mm)
Knee Travel (Z-axis manual)	16 in. (406mm)
Ram Travel	24 in. (610mm)
Throat Distance (min.)	4 1/4 in. (171mm)
Throat Distance (max.)	28 1/4 in. (476mm)
Table to Spindle Nose Gage line (min.)	1 in. (25.4mm)
Max. Weight of Workpiece	850 lbs. (386 kgs.)

Table

Overall Sizes	10 x 50 in. (254 x 1270mm)
T-Slots	3 on 2 1/2 in. (64mm) centers
T-Slot Size	5/8 in. (16mm)
Height above floor (max.)	48 5/8 in. (1235mm)

Milling

Feed Rate (Power Optional) Please see Chart

Space and Weight

Floor Area	7 x 10 ft. (2.1 x 3.1m)
Height	96 in. (2438mm)
Net Weight	3300 lbs. (1500kgs)
Shipping Weight	3498 lbs. (1590kgs)

Power

Electrical Supply – 60/50 3 phase
Hz. 220/230/380/415/
440/460/575V

Color

Standard Machine Gray/ACER
White with Burgundy
Stripes

e-mill 3VKH

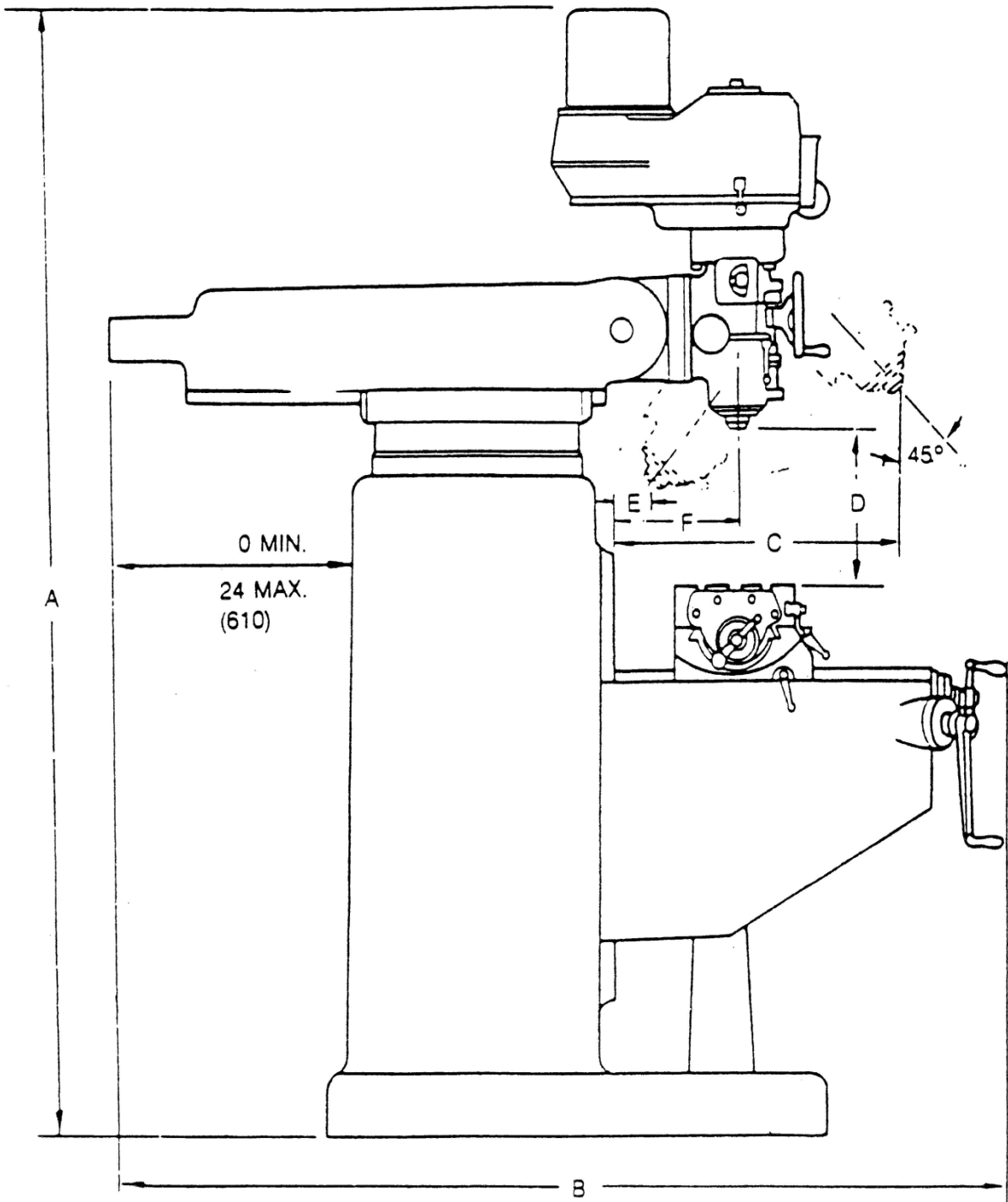

	A	B	C	D	E	F
Min.		56"	11 1/4"	2 1/2"	1	4"
		1422mm	285mm	64mm		102mm
Max.	94"	79"	35 1/4"	22 1/2"	18"	27"
	2388mm	2007mm	895mm	572mm	533mm	686mm

Figure 3. Principal Dimension of 3VKH

E-MILL 3VKH MACHINE SPECIFICATIONS:

Range

Table Travel (X-axis)	50" Table: 27"/ 686mm	54" Table: 31"/ 787mm
Saddle Travel (Y-axis)	17 in. (432mm)	
Quill Travel	5 in. (127mm)	
Knee Travel (Z-axis manual)	19 in. (483mm)	
Ram Travel	20 in. (508mm)	
Throat Distance (min.)	4 1/4 in. (171mm)	
Throat Distance (max.)	28 1/4 in. (476mm)	
Table to Spindle Nose Gage line (min.)	3 in. (76.2mm)	
Max. Weight of Workpiece	850 lbs. (386 kgs.)	

Table

Overall Sizes	10 x 50 in. (254 x 1270mm)	10 x 54 in. (254 x 1372mm)
T-Slots	3 on 2 1/2 in. (64mm) centers	
T-Slot Size	5/8 in. (16mm)	
Height above floor (max.)	51 5/8 in. (1311mm)	

Milling

Feed Rate (Power Optional) Please see Chart

Space and Weight

Floor Area	7 x 10 ft. (2.1 x 3.1m)	
Height	96 in. (2439mm)	
Net Weight	3550 lbs. (1614kgs)	3700 lbs. (1682kgs)
Shipping Weight	3749 lbs. (1704kgs)	3899 lbs. (1772kgs)

Power

Electrical Supply – 60/50 Hz. 3 phase
220/230/380/415/
440/460/575V

Color

Standard Machine Gray/ACER
White with Burgundy
Stripes

e-mill 5VK

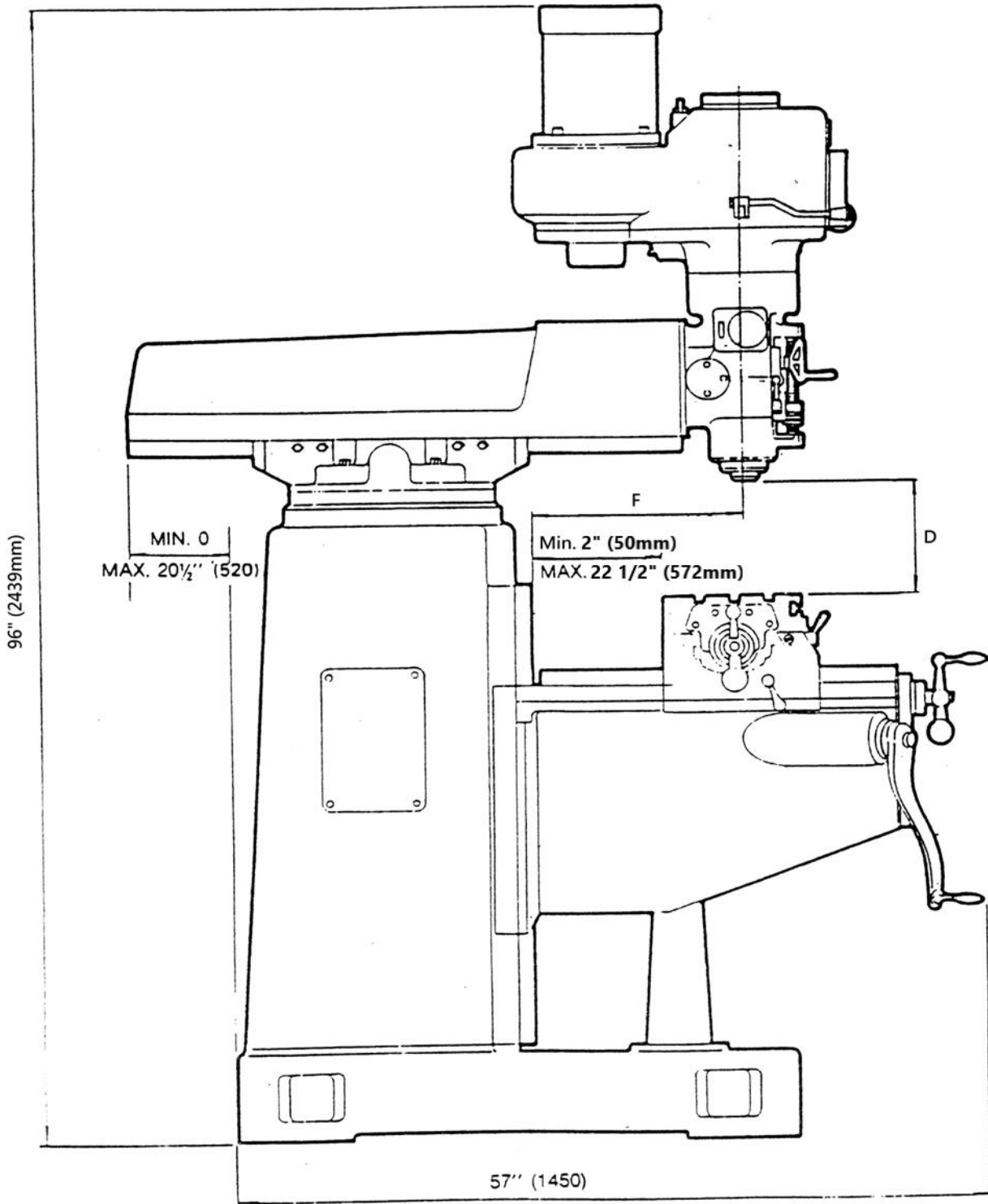

	A	B	C	D	E	F
Min.		-	-	2"	-	2 1/4"
		-	-	50mm		57mm
Max.	-	-	-	22 1/2"	-	23 3/4"
	-	-	-	572mm	-	603mm

Figure 4. Principal Dimension of 5VK

E-MILL 5VK MACHINE SPECIFICATIONS:

Range

Table Travel (X-axis)	50" Table: 27"/ 686mm	54" Table: 31"/ 787mm
Saddle Travel (Y-axis)	17 in. (432mm)	
Quill Travel	5 in. (127mm)	
Knee Travel (Z-axis manual)	19 in. (483mm)	
Ram Travel	24 in. (610mm)	
Throat Distance (min.)	4 1/4 in. (171mm)	
Throat Distance (max.)	28 1/4 in. (476mm)	
Table to Spindle Nose Gage line (min.)	4 in. (100mm)	
Max. Weight of Workpiece	850 lbs. (386 kgs.)	

Table

Overall Sizes	10 x 50 in. (254 x 1270mm)	10 x 54 in. (254 x 1372mm)
T-Slots	3 on 2 1/2 in. (64mm) centers	
T-Slot Size	5/8 in. (16mm)	
Height above floor (max.)	51 5/8 in. (1311mm)	

Milling

Feed Rate (Power Optional) Please see Chart

Space and Weight

Floor Area	7 x 10 ft. (2.1 x 3.1m)	
Height	96 in. (2439mm)	
Net Weight	3750 lbs. (1705kgs)	3900 lbs. (1773kgs)
Shipping Weight	3949 lbs. (1795kgs)	4099 lbs. (1863kgs)

Power

Electrical Supply – 60/50 Hz. 3 phase
220/230/380/415/
440/460/575V

Color

Standard Machine Gray/ACER
White with Burgundy
Stripes

e-mill 6VK

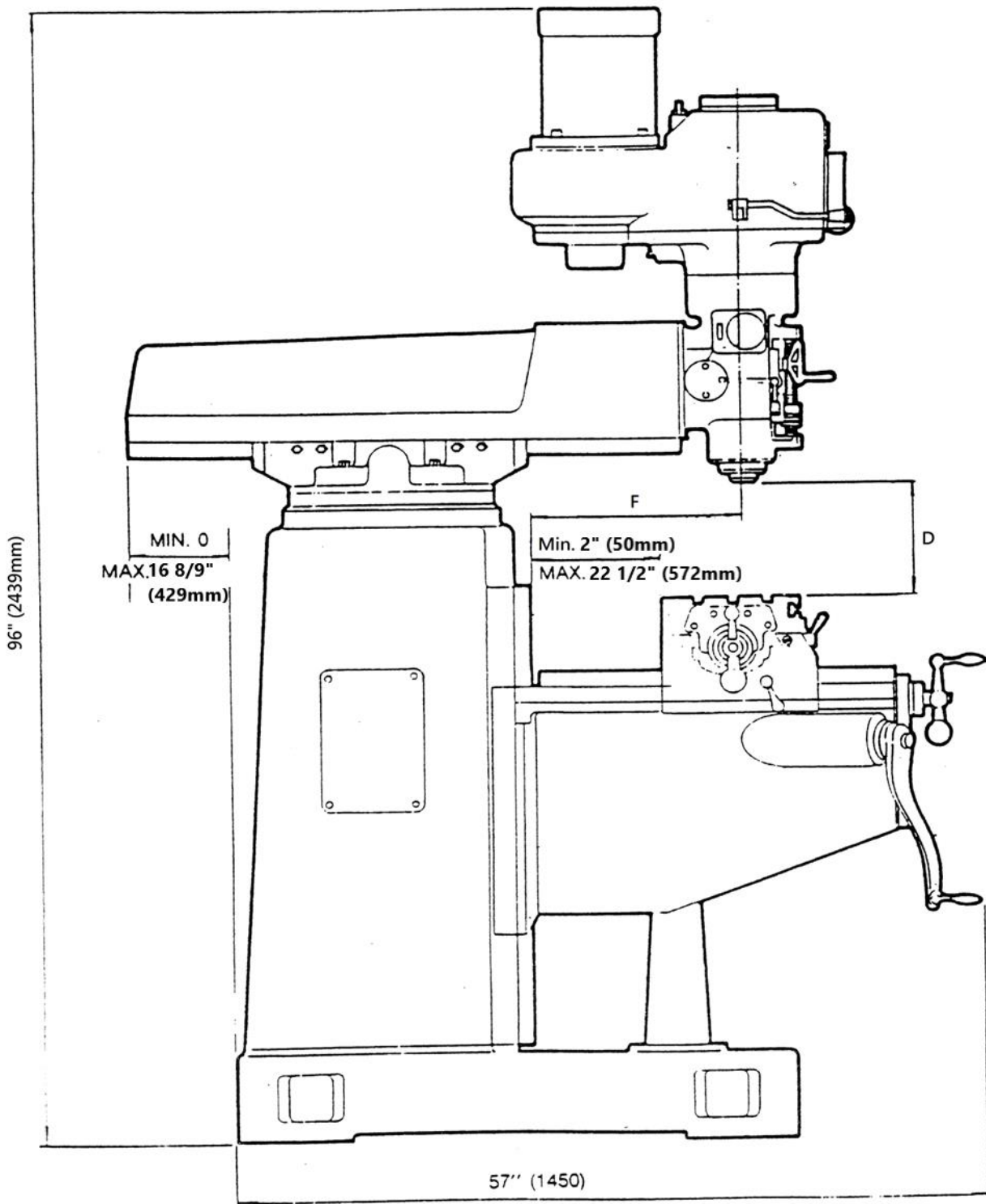

	A	B	C	D	E	F
Min.		-	-	2"	-	2 1/4"
		-	-	50mm		57mm
Max.	-	-	-	22 1/2"	-	23 3/4"
	-	-	-	572mm	-	603mm

Figure 5. Principal Dimension of 6VK

E-MILL 6VK MACHINE SPECIFICATIONS:

Range

Table Travel (X-axis)	59" Table: 47 1/4"/ 1200mm
Saddle Travel (Y-axis)	15 in. (381mm)
Quill Travel	5 in. (127mm)
Knee Travel (Z-axis manual)	19 3/4in. (502mm)
Ram Travel	16 8/9 in. (429mm)
Throat Distance (min.)	4 1/4 in. (171mm)
Throat Distance (max.)	28 1/4 in. (476mm)
Table to Spindle Nose Gage line (min.)	3 2/7 in. (84mm)
Max. Weight of Workpiece	1100 lbs. (500 kgs.)

Table

Overall Sizes	11 3/4 x 59 in. (300 x 1500mm)
T-Slots	3 on 2 1/2 in. (64mm) centers
T-Slot Size	5/8 in. (16mm)
Height above floor (max.)	52 in. (1321mm)

Milling

Feed Rate (Power Optional) Please see Chart

Space and Weight

Floor Area	7 x 10 ft. (2.1 x 3.1m)
Height	95 in. (2413mm)
Net Weight	4960 lbs. (2255kgs)
Shipping Weight	5181 lbs. (2355kgs)

Power

Electrical Supply – 60/50 3 phase
Hz. 220/230/380/415/
440/460/575V

Color

Standard Machine Gray/ACER
White with Burgundy
Stripes

2-2 Milling Head Specification

Milling Head Specification				
Model	3VS/3VSII/3VK	3VKH	5VK	6VK
Power	3 HP (2.25KW)		5 HP (3.75KW)	
Motor RPM	1750			
Speed Range RPM	Variable Speed			
Low	0~520		0~560	
High	500~4500		500~4500	
Quill Travel	5" (127mm)			
Quill Diameter	3.375" (86mm)		3.94" (100mm)	
Spindle Taper	R 8		NST/ISO #40	
Spindle Diameter	2.677" (68mm)		3.5" (89mm)	
Spindle Feed Rate	0.0015"/rev. (0.038mm)			
	0.003/rev. (0.076mm)			
	0.006/rev. (0.152mm)			
Drill Capacity Manual Power	Φ 0.875" (22mm)		Φ 1.25" (32mm)	
	Φ 0.37" (9.4mm)		Φ 0.625" (16mm)	
Boring Capacity	Φ 6" (125.4mm)		Φ 8" (200mm)	
Milling Capacity	2.0 in ³ /min		2.5 in ³ /min	
Spindle to Column Minimum Maximum				
	4" (101.6mm)			
	20" (508mm)		27" (685.8mm)	

2-3 Features & Description of Machines

e-mill 3VS & 3VSII (Note: e-mill 3VK has similar features!)

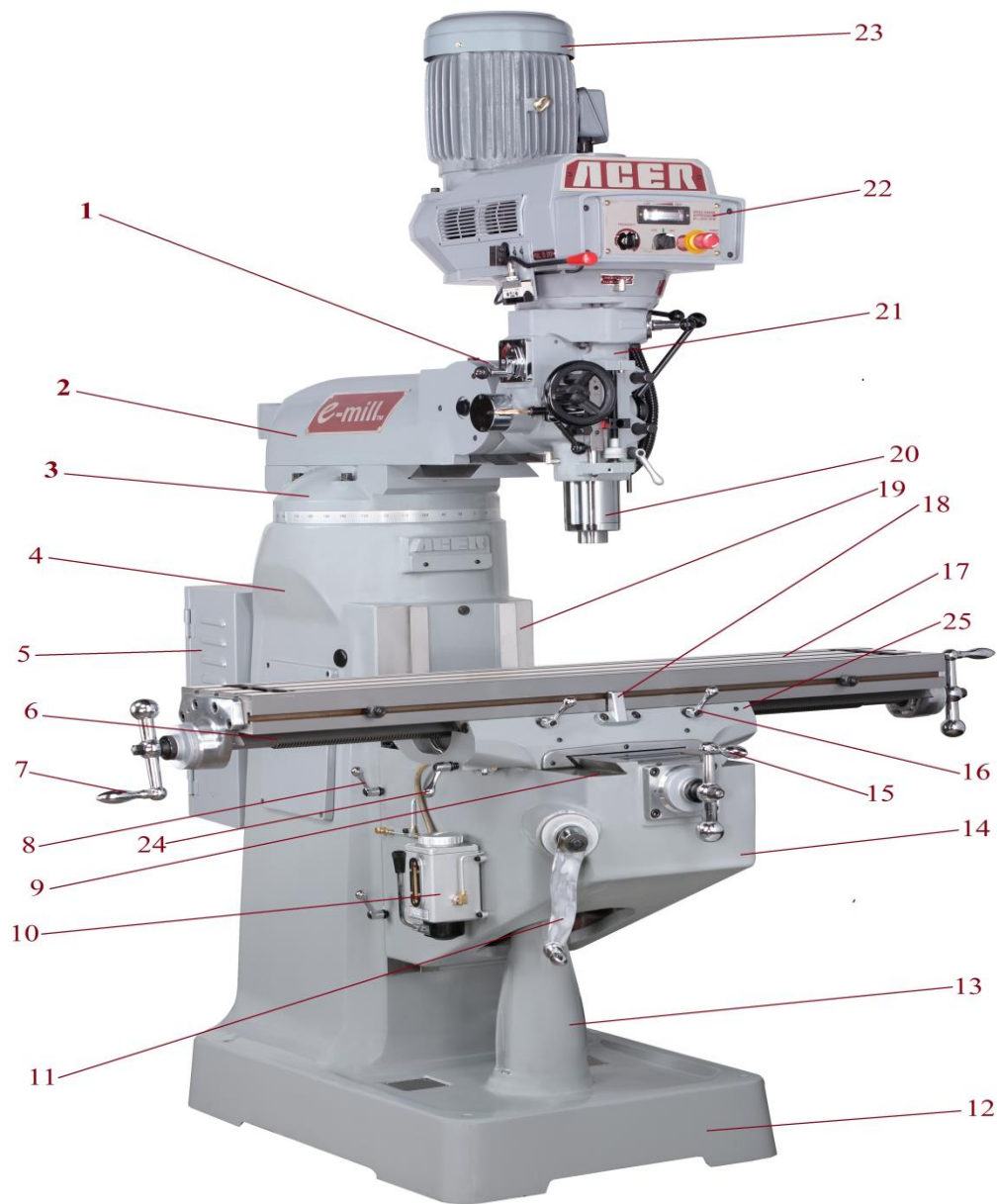

Features of 3VS & 3VSII					
Item#	Description	Item#	Description	Item#	Description
1	Ram Adaptor	10	One-shot Lube	19	Column Dovetail Way
2	Ram	11	Knee Crank Handle	20	Spindle
3	Turret	12	Dish-in Base	21	Head Housing
4	Column	13	Pedestal	22	Control Panel
5	Electric Cabinet	14	Knee	23	Spindle Motor
6	Table Dovetail Way	15	Saddle Crank Handle	24	Saddle Lock
7	Table Crank Handle	16	Table Lock	25	Saddle
8	Knee Lock	17	Table		
9	Knee Dovetail Way	18	Table Stop Bracket		

e-mill 3VKH (Note: e-mill 5VK has similar features except no ram adaptor!)

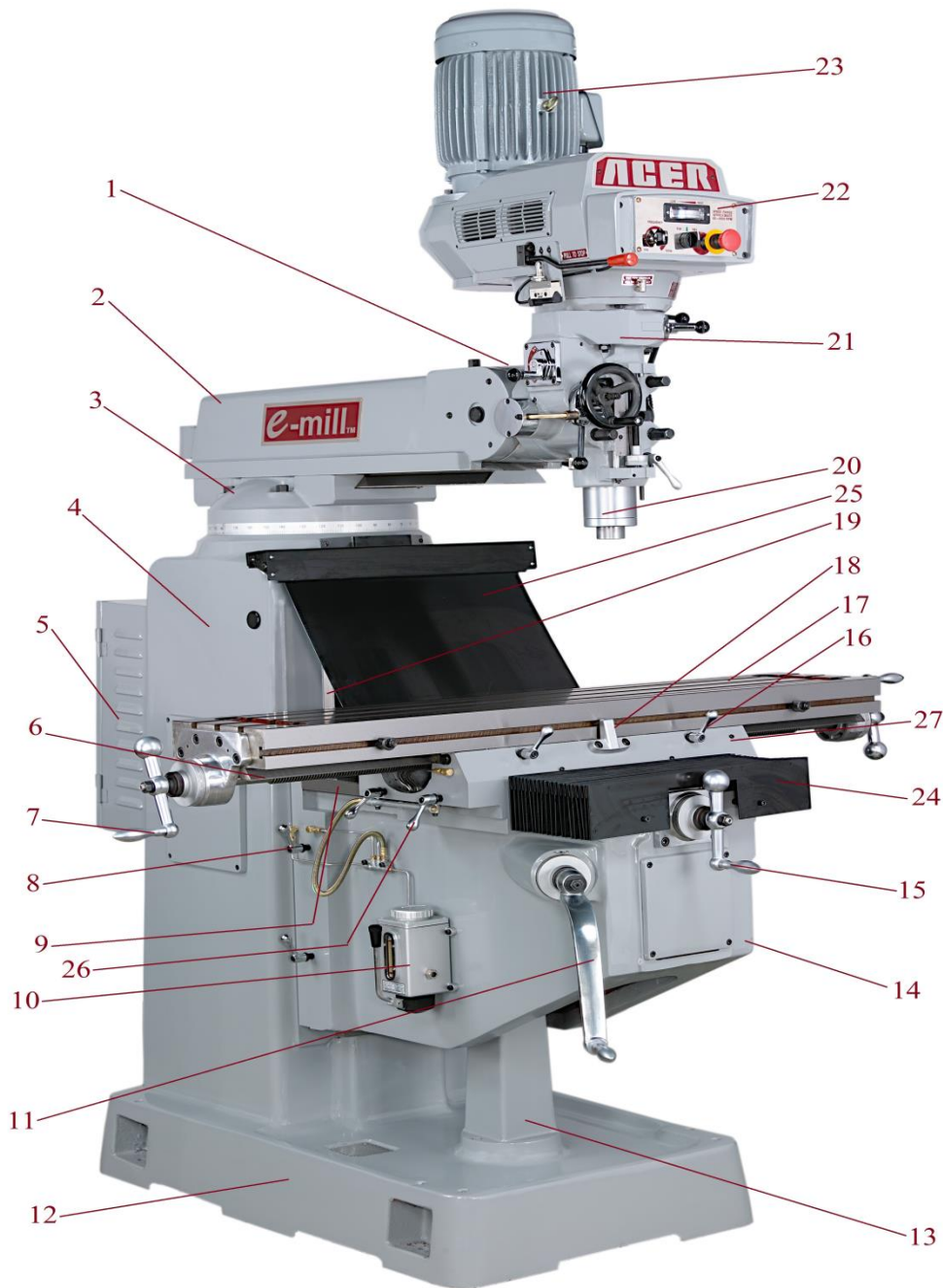

Features of 3VKH					
Item#	Description	Item#	Description	Item#	Description
1	Ram Adaptor	10	One-shot Lube	19	Column Dovetail Way
2	Ram	11	Knee Crank Handle	20	Spindle
3	Turret	12	Dish-in Base	21	Head Housing
4	Column	13	Pedestal	22	Control Panel
5	Electric Cabinet	14	Knee	23	Spindle Motor
6	Table Dovetail Way	15	Saddle Crank Handle	24	Front Bellow Cover
7	Table Crank Handle	16	Table Lock	25	Back Roller Cover
8	Knee Lock	17	Table	26	Saddle Lock
9	Knee Dovetail Way	18	Table Stop Bracket	27	Saddle

e-mill 6VK

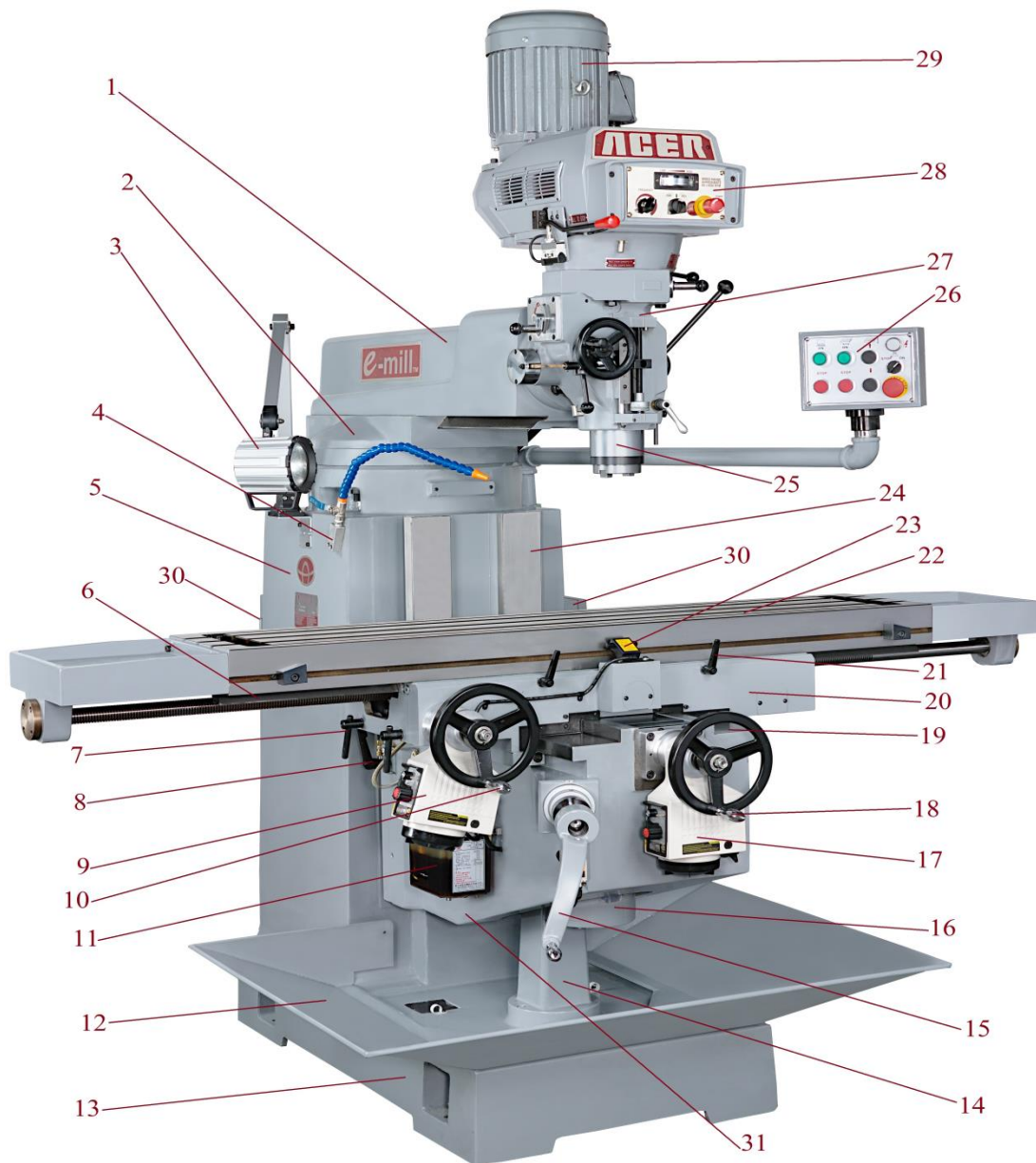

Features of 6VK					
Item#	Description	Item#	Description	Item#	Description
1	Ram	11	Auto Lubricator	21	Table Lock
2	Turret	12	Chip Pan	22	Table
3	Halogen Light	13	Dish-in Base	23	Table Stop Bracket
4	Coolant Nozzle	14	Pedestal	24	Column Square Way
5	Column	15	Knee Crank Handle	25	Spindle
6	Table Dovetail Way	16	Elevation Motor	26	Operation Panel
7	Saddle Lock	17	Saddle Powerfeed	27	Head Housing
8	Knee Lock	18	Saddle Crank Handle	28	Control Panel
9	Table Powerfeed	19	Saddle/Knee Square Way	29	Spindle Motor
10	Table Crank Handle	20	Saddle	30	Electric Cabinet
				31	Knee

3. UNCRATING & CLEANING

Carefully remove protective crating so machine and parts are not marred or damaged. In the event of damage in transit, immediately notify the distributor from whom the machine was purchased, as well as the transportation company making delivery.

Machine should be lifted by placing a sling under the ram as illustrated on page 33, 34, 35.

Thoroughly clean protective coating from machine with suitable cleaning solution.

<p style="text-align: center;">WARNING! IT IS NOT RECOMMENDED THAT GASOLINE OR ANY OTHER HIGHLY INFLAMMABLE CLEANING AGENT BE USED.</p>
--

Do not move the table, knee, saddle or ram until all slideways have been well cleaned and lubricated. Then, by hand, move table, saddle and knee to limit stop in one direction. Clean and lubricate exposed ways and then move each unit to the opposite limit stop and similarly clean lubricate the exposed ways. Loosen bolts to unlock ram and move forward and backward the full length to clean and lubricate.

4. INSTALLATION

Loosen four locknuts in front of milling head out to detent and rotate head to vertical position. Proceed with alignment of head as described on page 71. Tighten nuts evenly, using normal pressure. Care should be taken to avoid excessive tightening since this will cause distortion in the quill. Tighten all nuts to 25 ft-lbs torque, and then repeat the procedure to 50 ft-lbs.

4-1 Lifting Machine

The column and base are a one-piece casting. Machine should be lifted by placing a sling under the ram. (Sling is made from polyester webbing and flat nylon, 2" wide, 1/5" thickness, 8 meters length and rated breaking strength at 4,400lbs or 2,000kgs.)

Note: Position of ram and table when lifting with a sling.

e-mill 3VS, 3VSII & e-mill 6VK

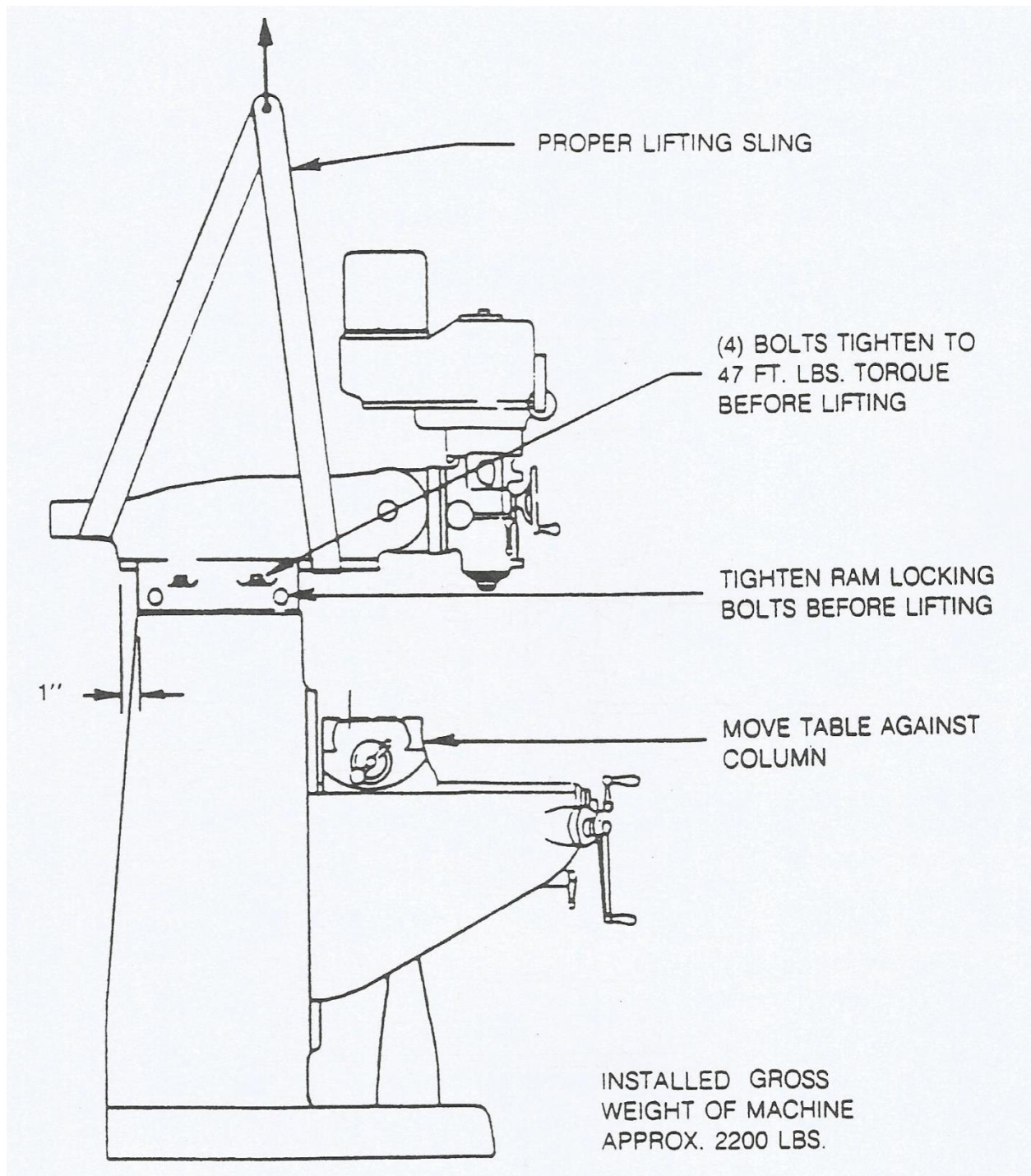

Figure 6. Lifting method of e-mill 3VS & e-mill 6VK

e-mill 3VK

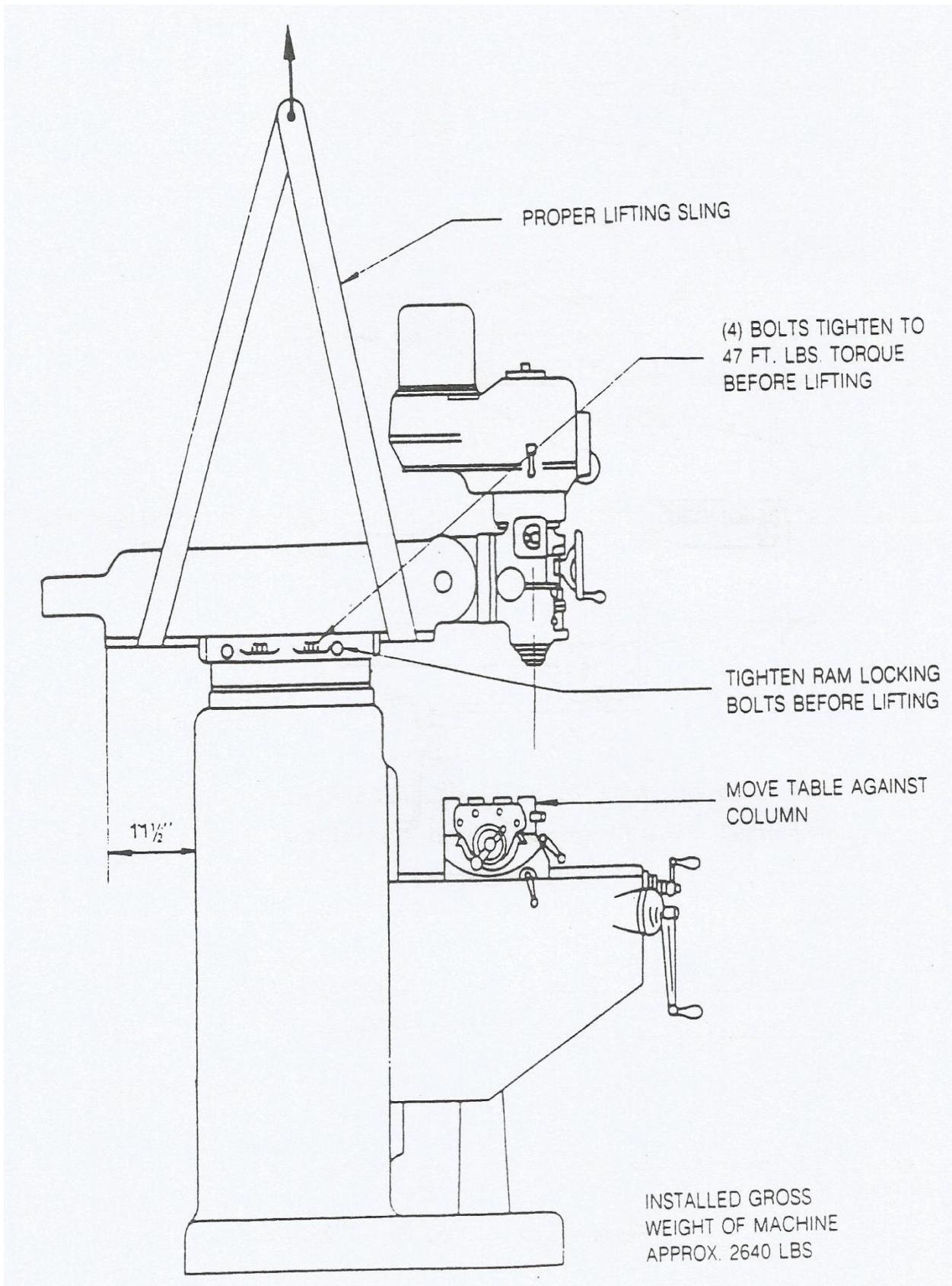

Figure 7. Lifting method of e-mill 3VK

e-mill 3VKH & e-mill 5VK

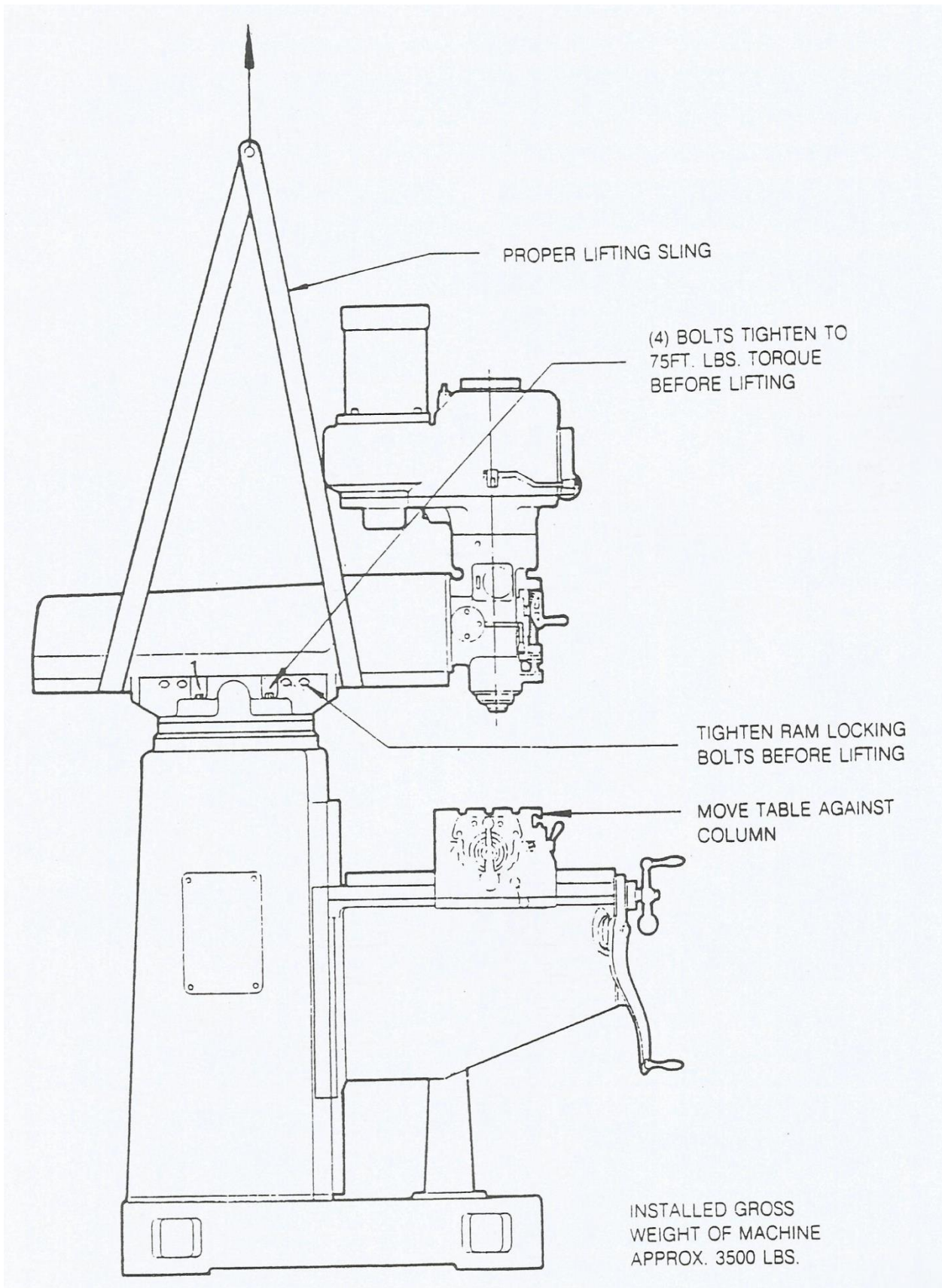

Figure 8. Lifting method of e-mill 3VKH & e-mill 5VK

4-2 Solid Foundation

When setting machine on a concrete foundation, it is advisable to use a little grout (thin mortar) to take care of any unevenness in the concrete, as well as to provide a solid foundation at all points.

When setting machine on a floor that has any surface irregularities, shims should be used to correct this condition to the greatest extent possible.

See figure illustrated for installation layout.

e-mill 3VS & e-mill 3VSII

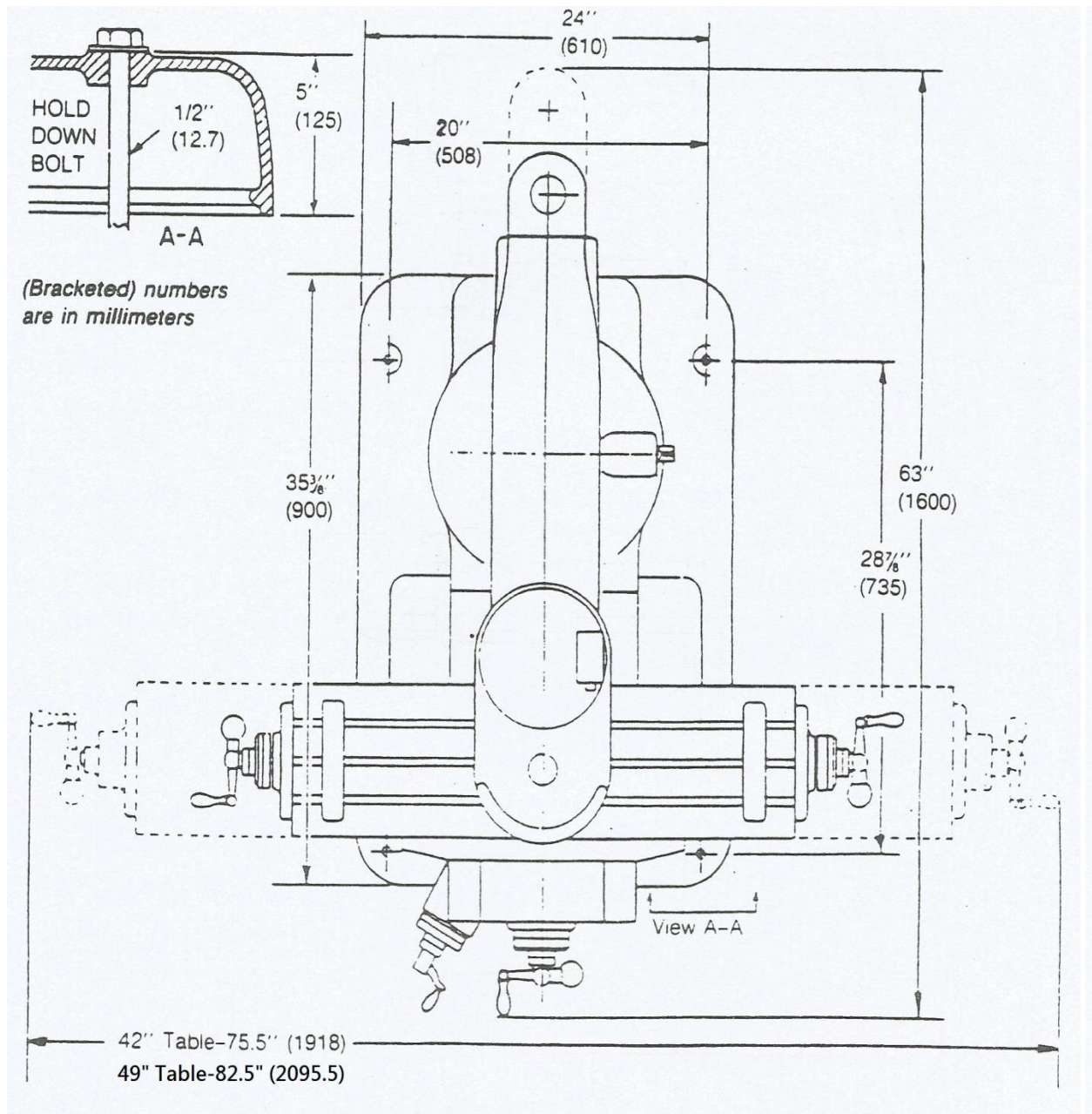

Figure 9. Installation layout

NOTE
IT IS RECOMMENDED THAT THE MACHINE BE SECURED TO THE FLOOR TO PREVENT MOVEMENT OR TIPPING DUE TO OFF-CENTER LOADING.

Before securing machine to floor (i.e. tightening hold down bolts) make certain all four corners are making contact with floor after machine is leveled. If above condition is not met, it is possible to twist the column and put a bind into the ways.

e-mill 3VK

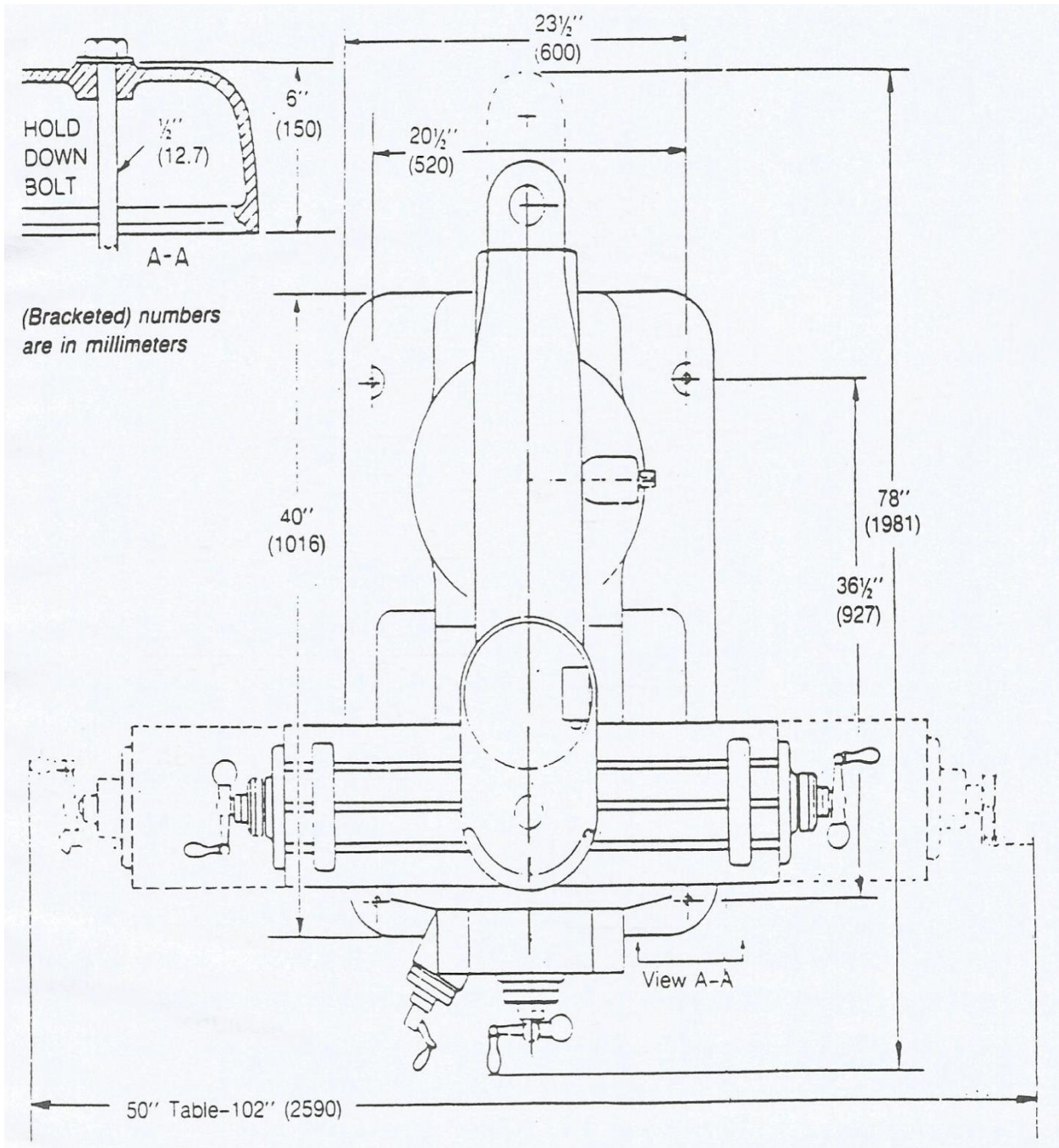

Figure 10. Installation layout

e-mill 3VKH & e-mill 5VK

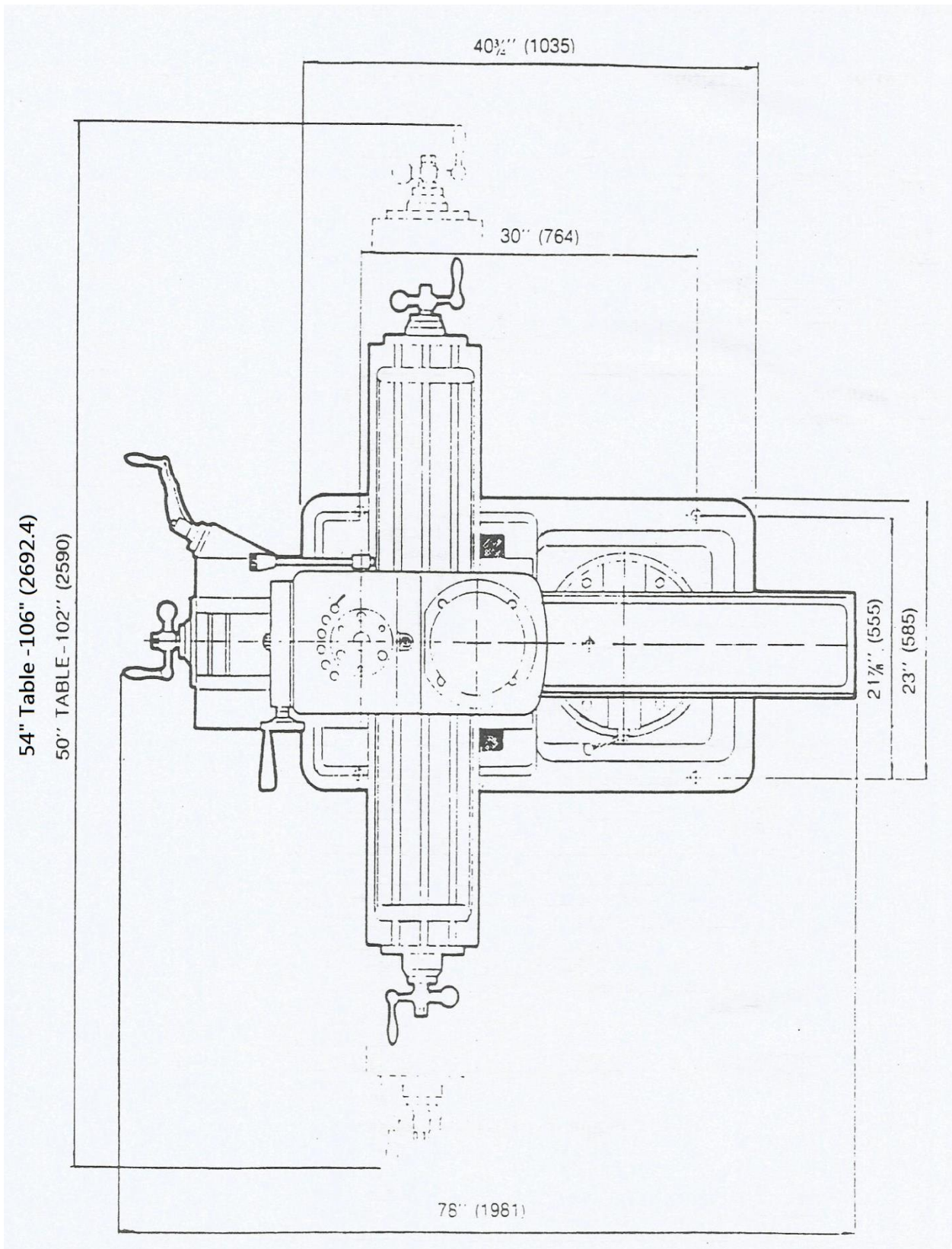

Figure 11. Installation layout

e-mill 6VK

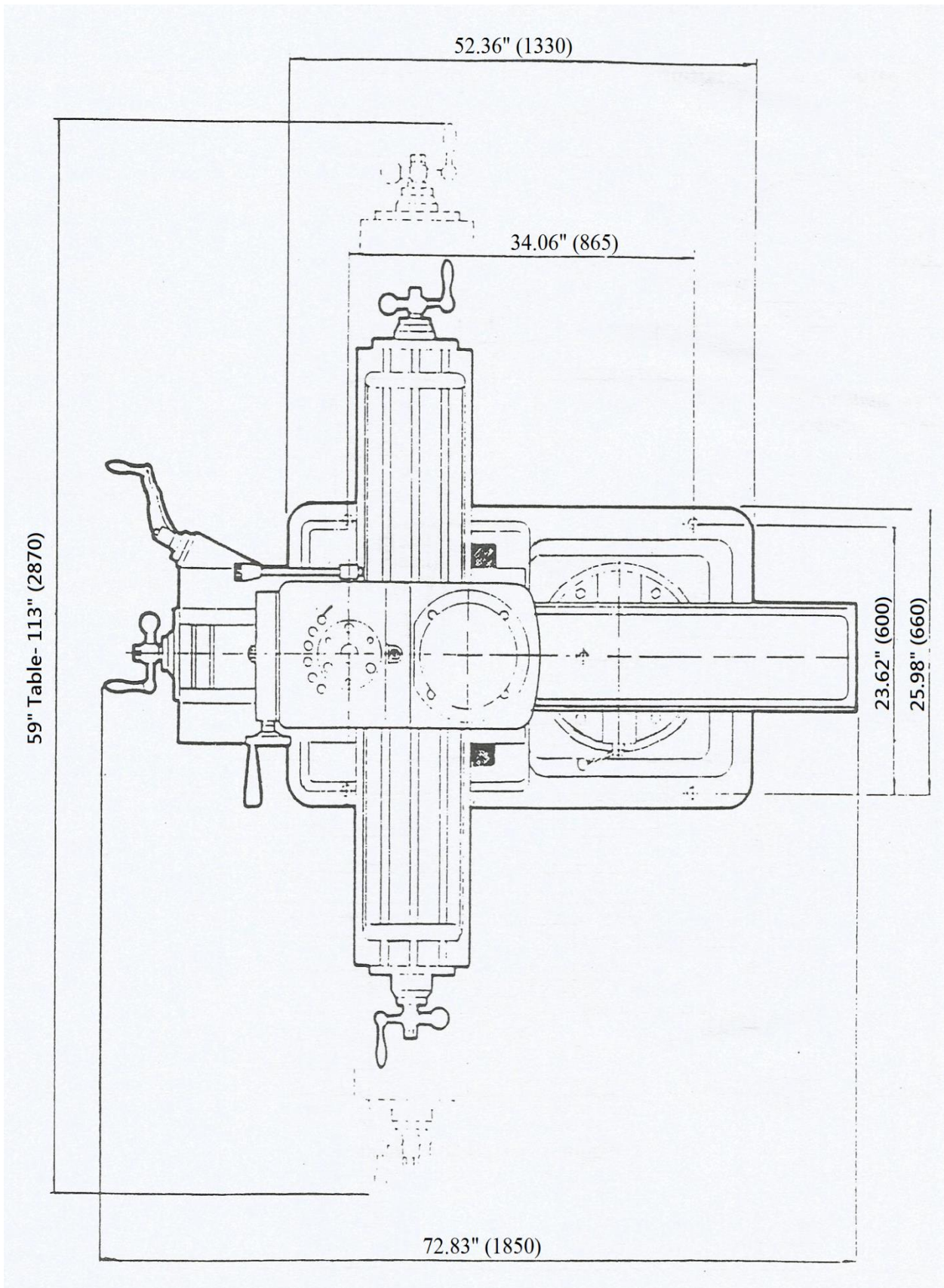
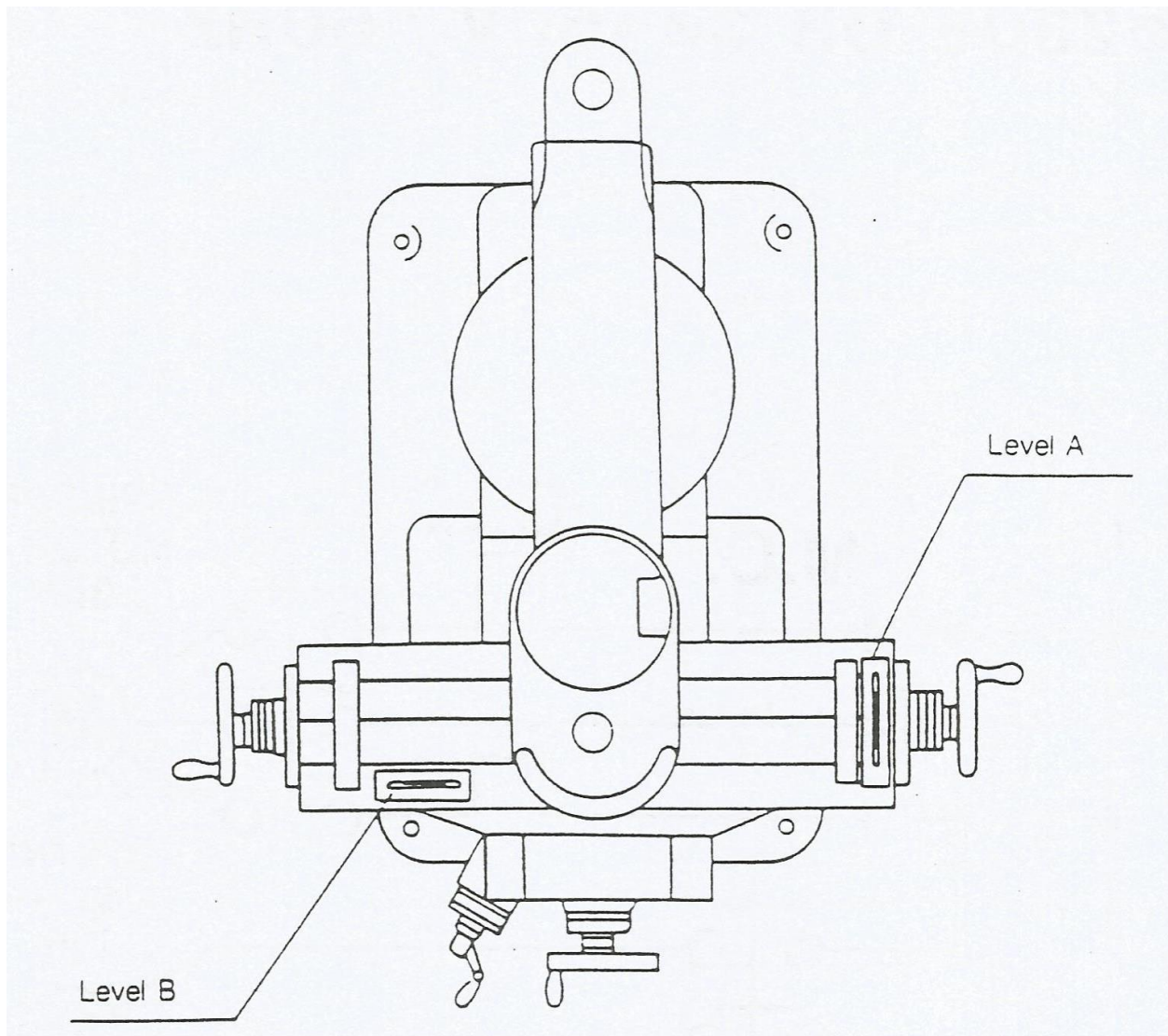

Figure 12. Installation layout

4-3 Leveling Machine

Set machine by leveling the work table lengthwise and crosswise with engineering precision levels.



4-4 Handles

When crating, the three ball crank handles are sometimes turned to face the machine. In this case the handles should be reversed before operation.

4-5 Connecting Power Supply

To connect the machine to the plant's power source, please have a qualified electrician proceed as follows:

1. Check required machine voltage against power source to ensure it is compatible with the power supply.

2. Connect machine wiring to power supply making sure connection is in compliance with all local electrical codes and safety regulations.
3. Check for correct spindle rotation. In the HIGH SPEED range, the spindle should rotate clockwise when viewed from the top of the machine.

<p>NOTE DRUM SWITCH AND HI-NEUTRAL-LO LEVER MUST BE IN "HI" RANGE.</p>
--

4-6 Wiring Diagram

A. Regular Circuit Diagram for 3VS, 3VSII, 3VK, 3VKH, 5VK

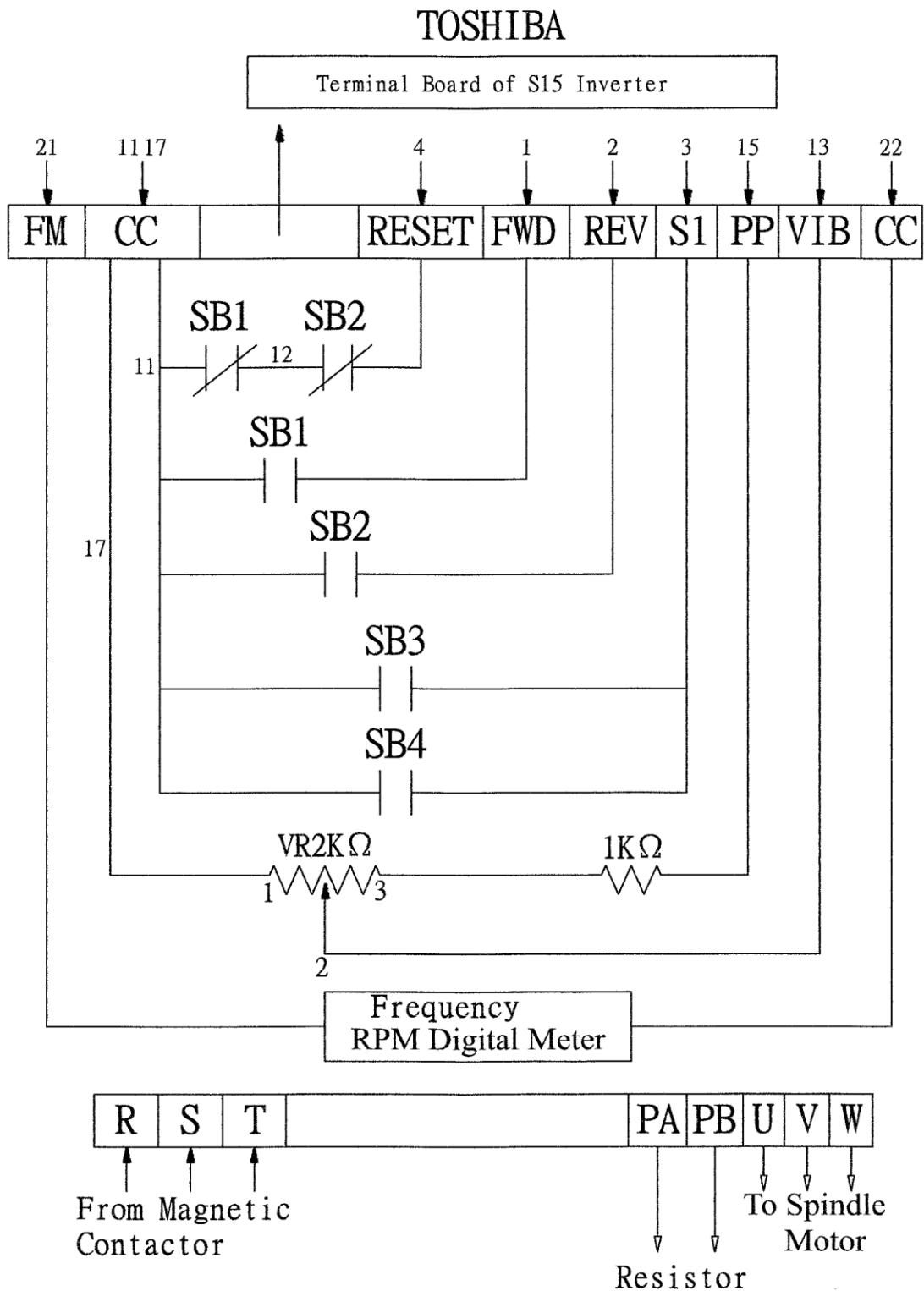

The Circuit Diagram

FUJ I

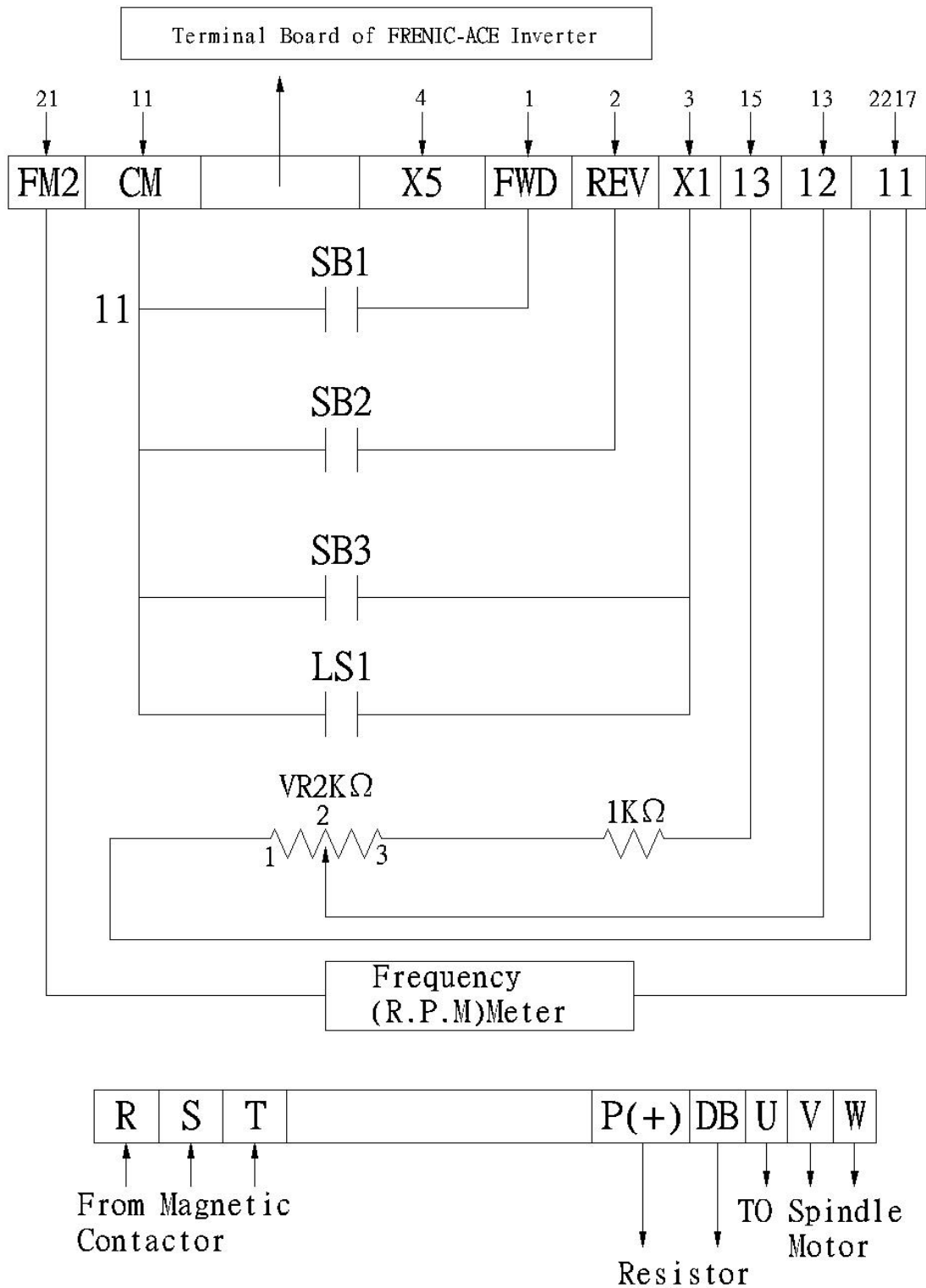

The Circuit diagram

Inverter Wiring Diagram

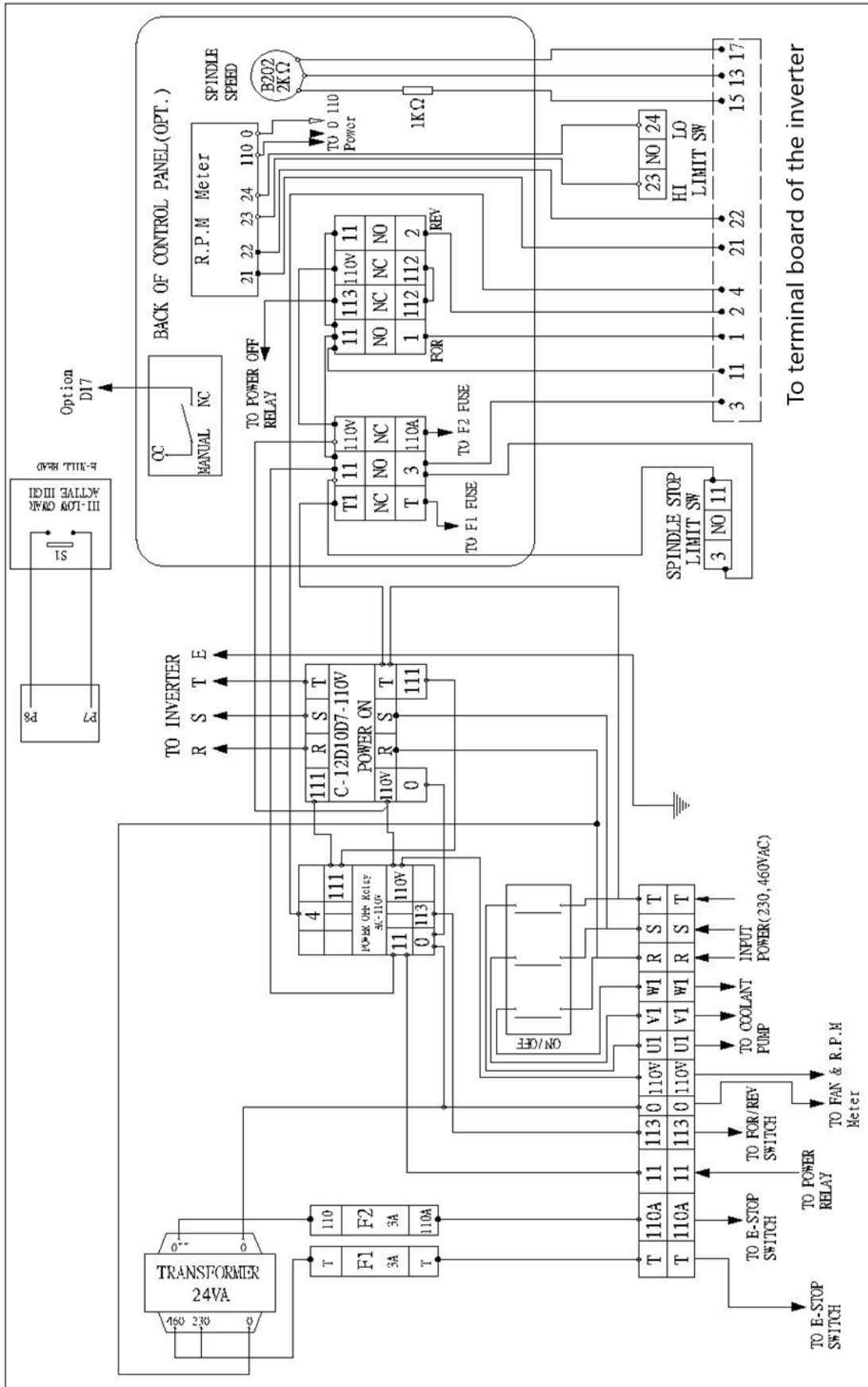

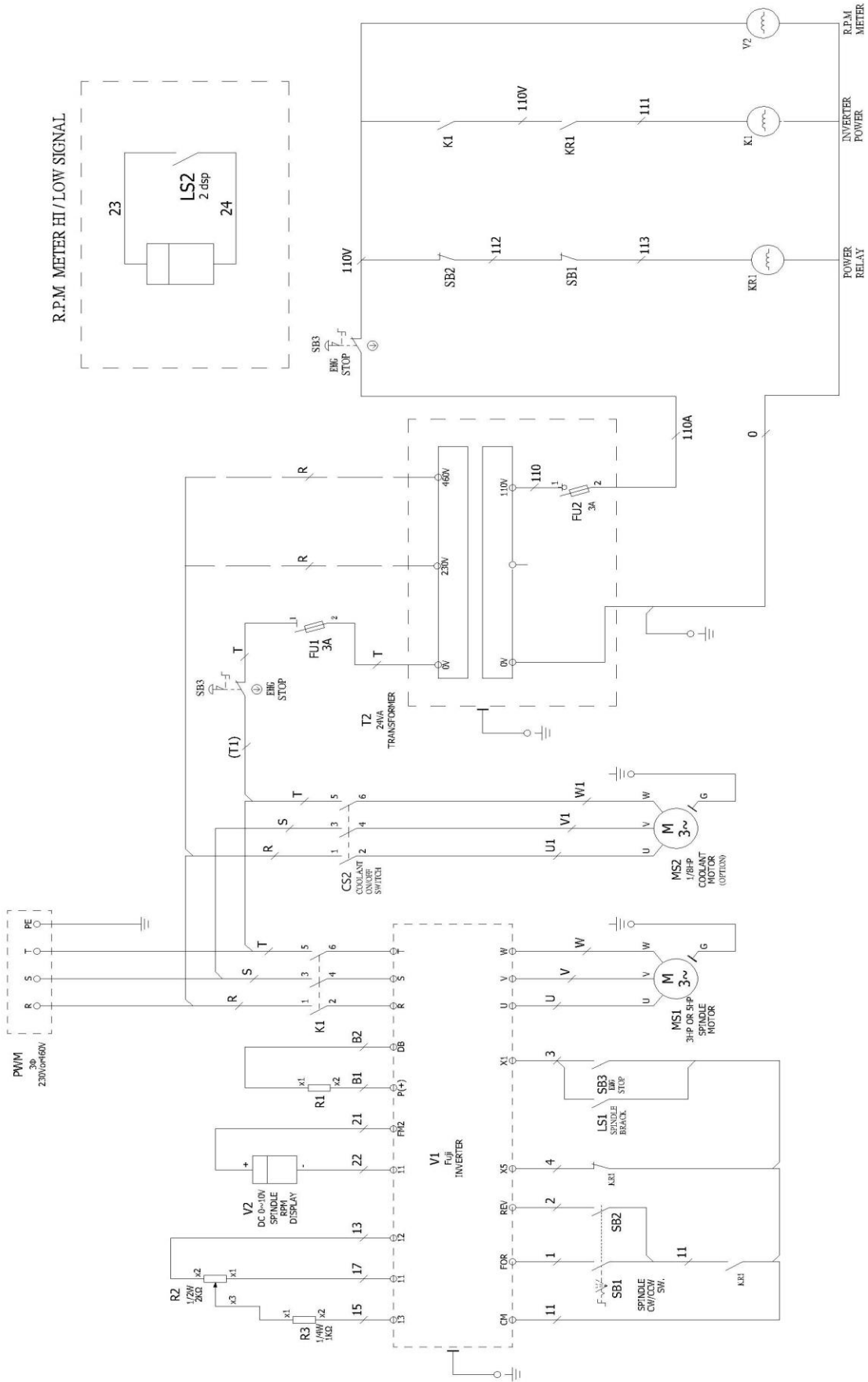

R.P.M METER HI/LOW SIGNAL

Back of the Control Panel

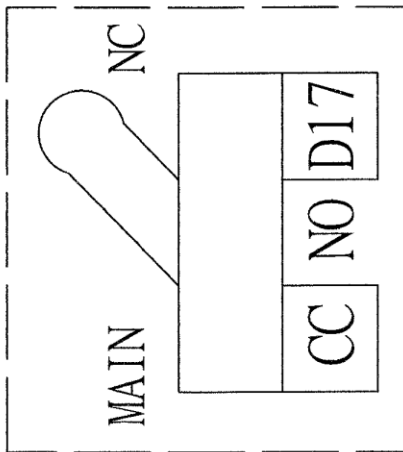

OPT.

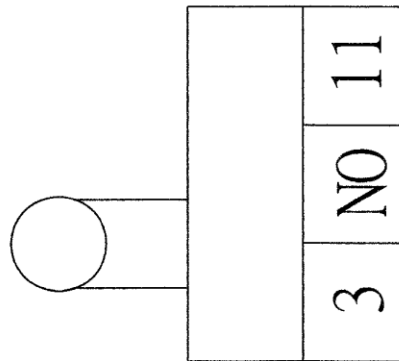

SB3

T1	11	110V
T	3	110A



SB1 SB2

11	113	110V	11
1	112	112	2

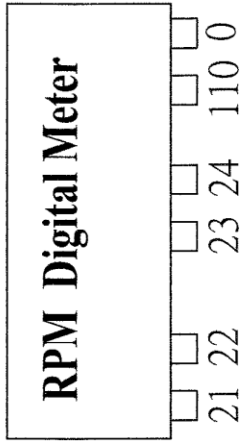
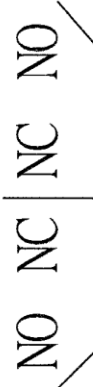

FOR
SPINDLE
SPEED

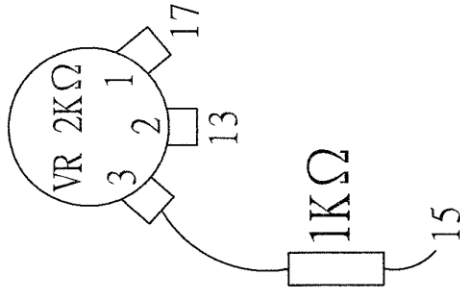

Control Panel

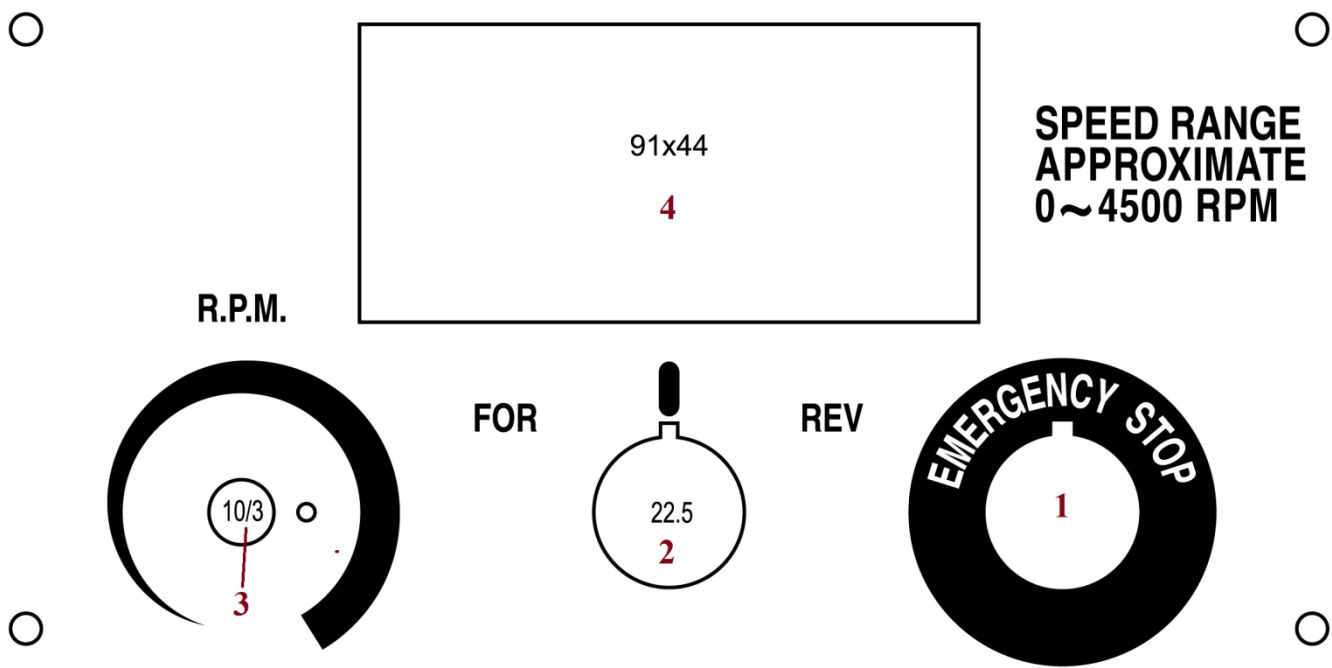

Item#	Part#	Description	QTY
1	9500	Emergency Switch	1
2	9501	F/R Switch	1
3	9502	Variable Resistor	1
4	9503-2	Digital Counter	1

Electric Cabinet Layout

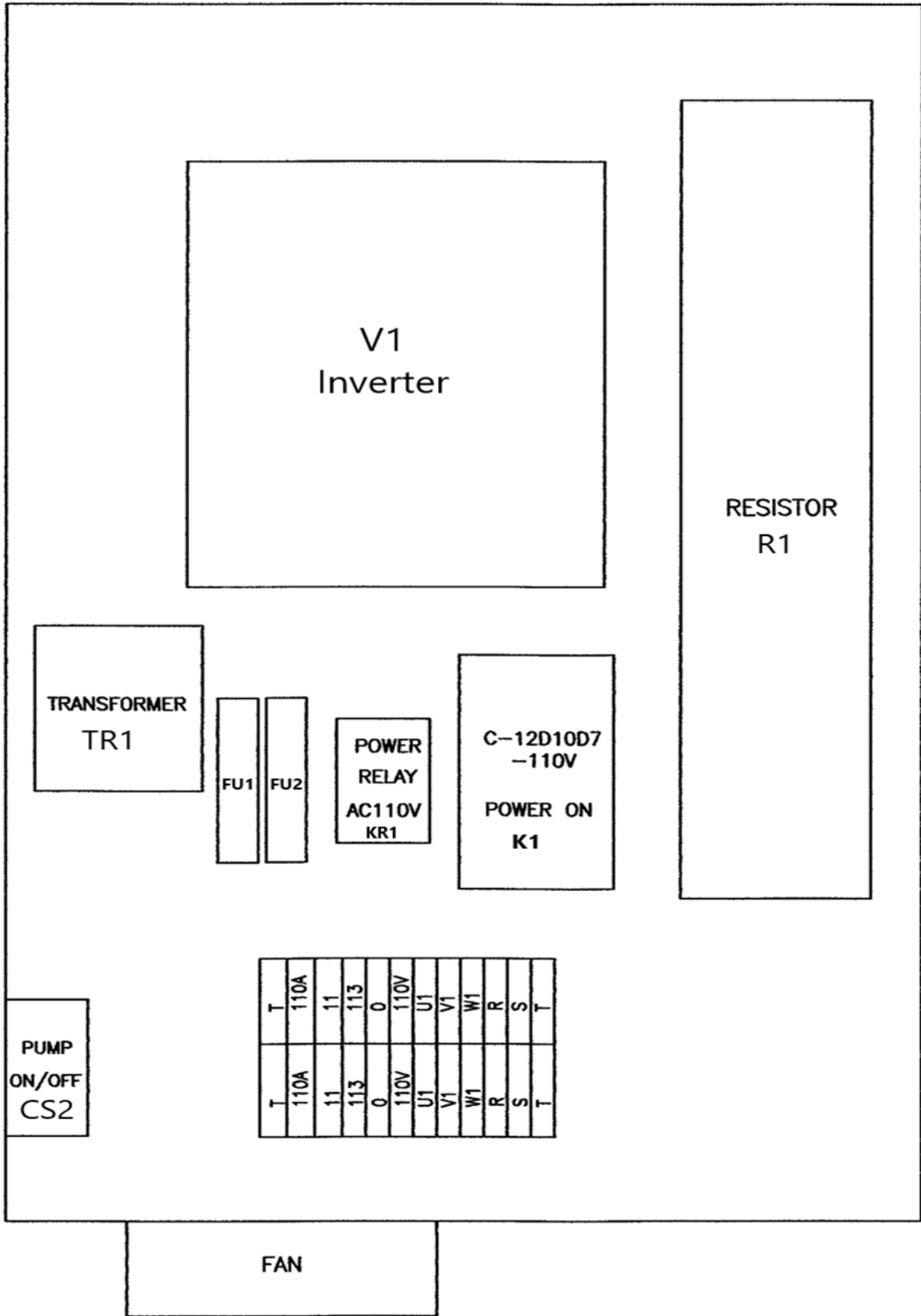

Electric Component List

ITEM NAME	ACER DESCRIPTION	Model: SUPPLIER	PARTS CATALOG NUMBER	QTY
V1	Spindle Inverter	Fuji	FRN0020E2S-2GB/3PH/185-250V	1
R1	Resistor		ZQR-450W/11Ω	3
V1	Spindle Inverter	Fuji	FRN0012E2S-4GB/3PH/350-528V	1
R1	Resistor		ZQR-450W/43.3Ω	3
V1	Spindle Inverter	Toshiba	VF-S15	1
R1	Resistor		ZQR-450W/6.5Ω	3
V1	Spindle Inverter	Toshiba	VF-S15	1
R1	Resistor		ZQR-450W/20Ω	3
FAN	Cooling Fan	Gulf	GA1123XBL/AC110V/120V/18/19W	1
FU1/F1	Fuse		3A	1
FU2/F2	Fuse		3A	1
K1	Magnetic Contactor	NHD	C-12D10D7-110V/50-60HZ	1
VR	Variable Resistor	Jason	RV24YN20S/B202/157C	1
R2	Resistor		1kΩ	1
TB1	Terminal Block	WAGO	20A-12P	1
LS1	Spindle Brack Limit	Tend	TZ-7311	1
LS2	Hi/Low Signal Limit	OMRON	SHL-02255	1
V2	RPM Meter	PWR	PWRMX-1A13A+C	1
SB1	Switch Forward	Allen-Bradley	S04509-RW A800FPMT32	1
SB2	Switch Reverse	Allen-Bradley	S04509-RW A800FPMT32	1
SB3	Emergency Stop	Allen-Bradley	S04509-RW A800FPMT35	1
E-STOP	Emergency Stop	Allen-Bradley	S04509-RW A800FPMT34	1
CS2	Coolant On/Off Switch		3P 10A 500V 2.2KW	1
KR1	Power Off Relay	OMRON	MY2N-GS 100/110VAC	1
T2	Transformer	Cheng Ten	IQ 24VA	1
MS1	Spindle Motor	Min-Loooun Electric	AEVF	1
MS2	Coolant Pump		1/8HP Option	1

B. Regular Circuit Diagram for 6VK

TOSHIBA S15 WIRING DIAGARM

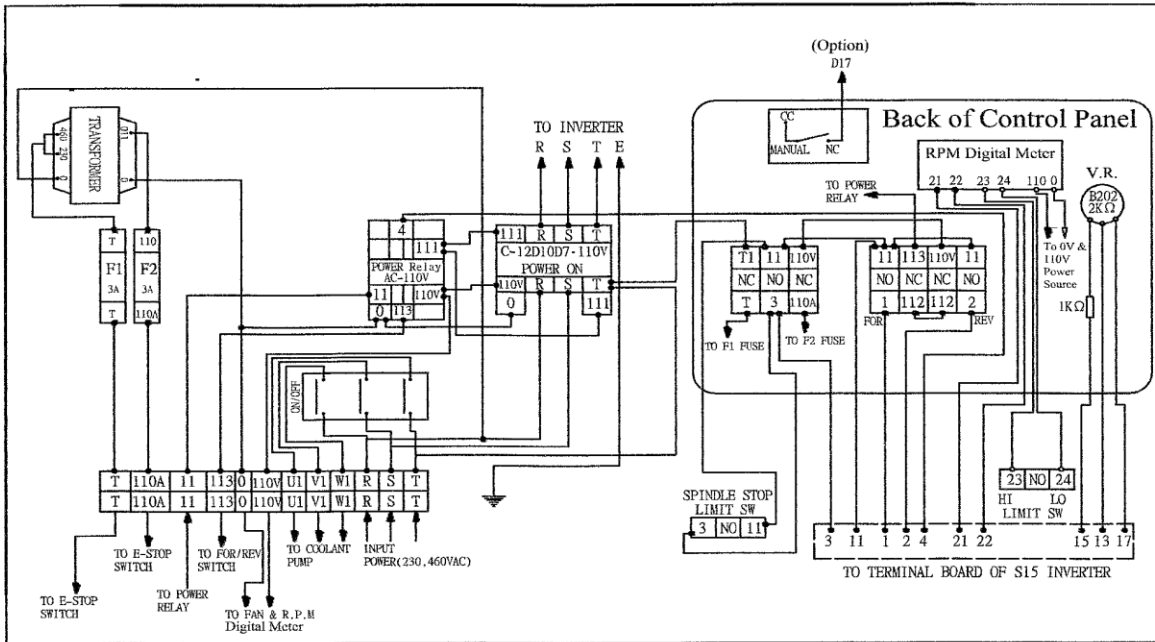

TOSHIBA

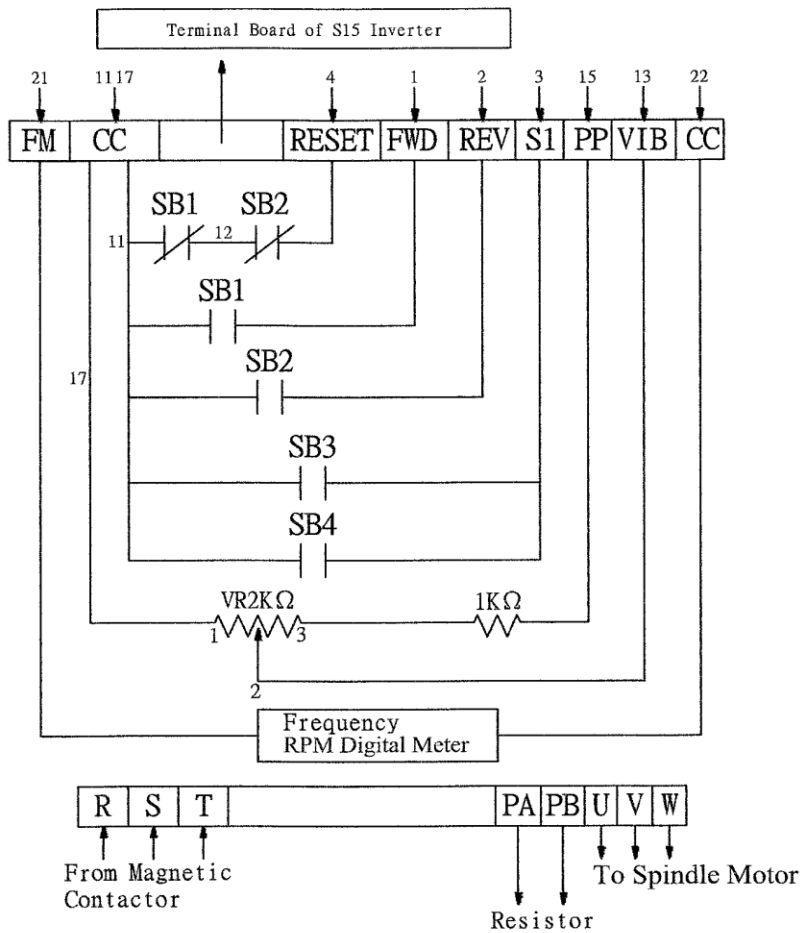

The Circuit Diagram

FUJI FRENIC-ACE WIRING DIAGRAM

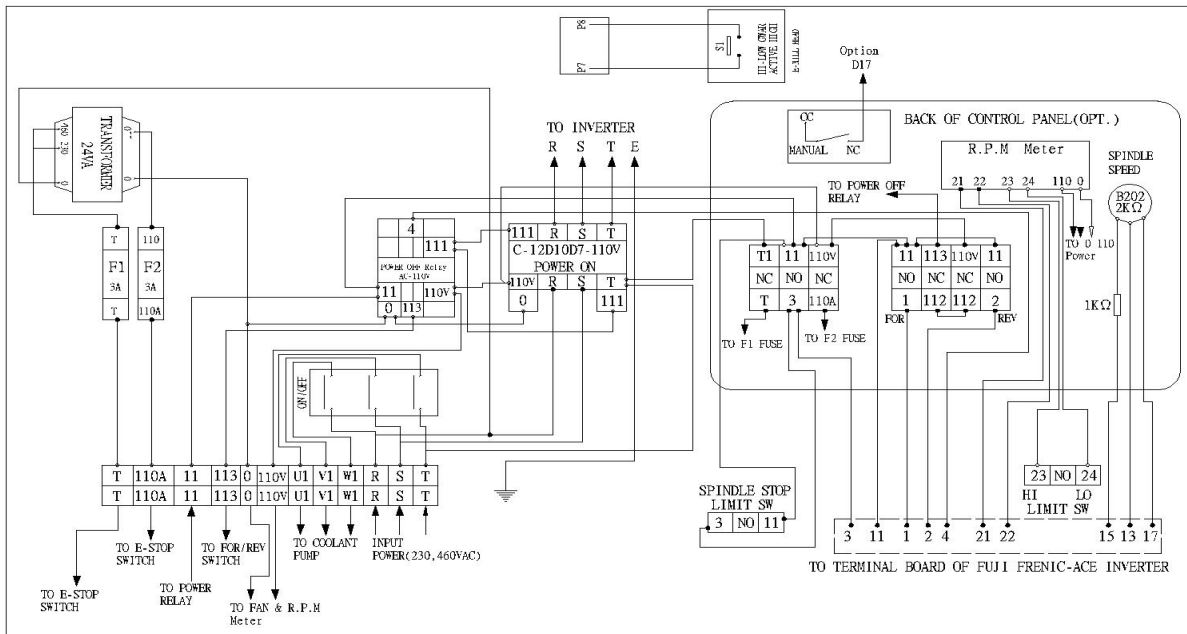

FUJ I

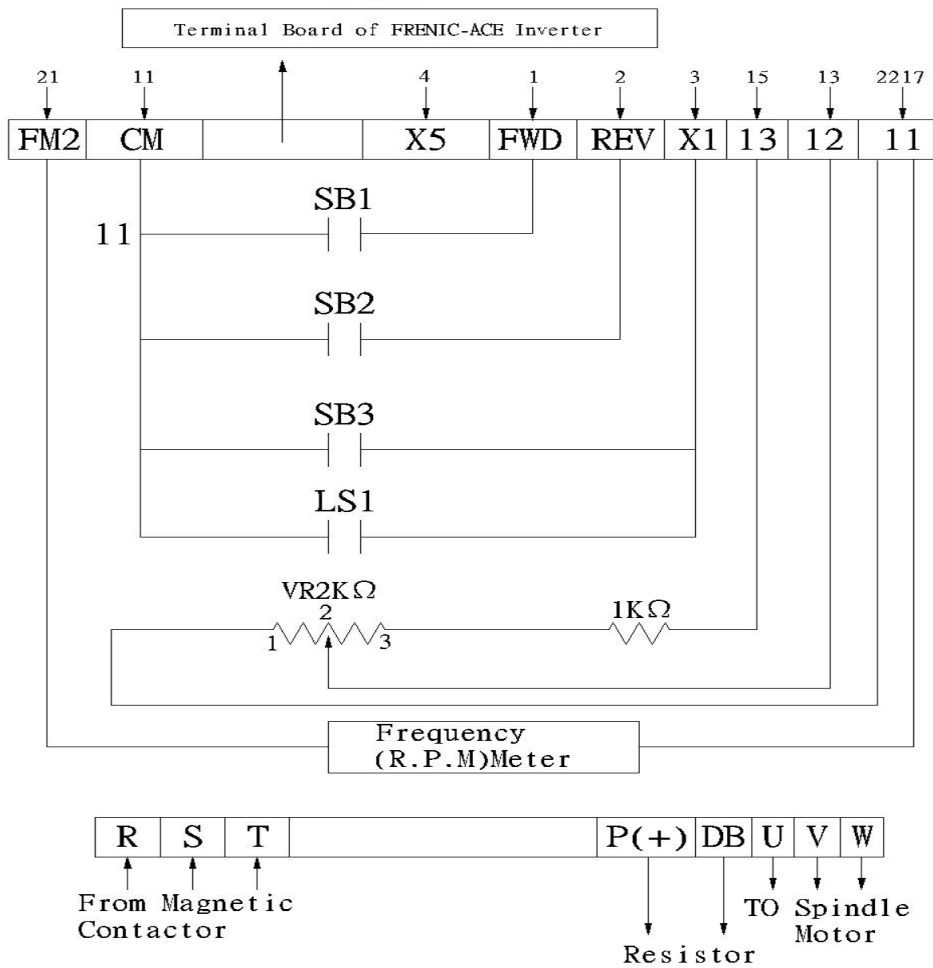

The Circuit diagram

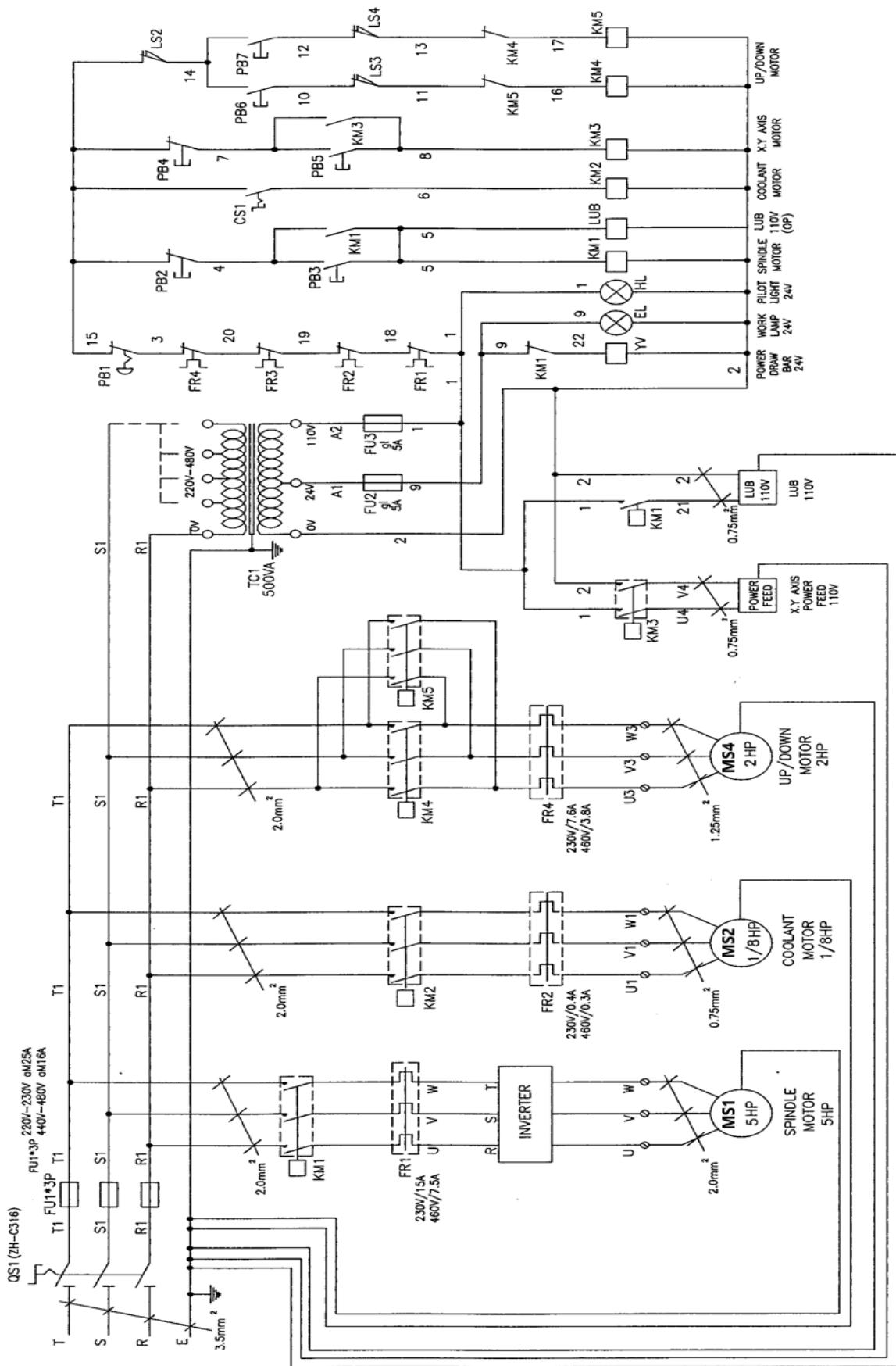

Operation Panel

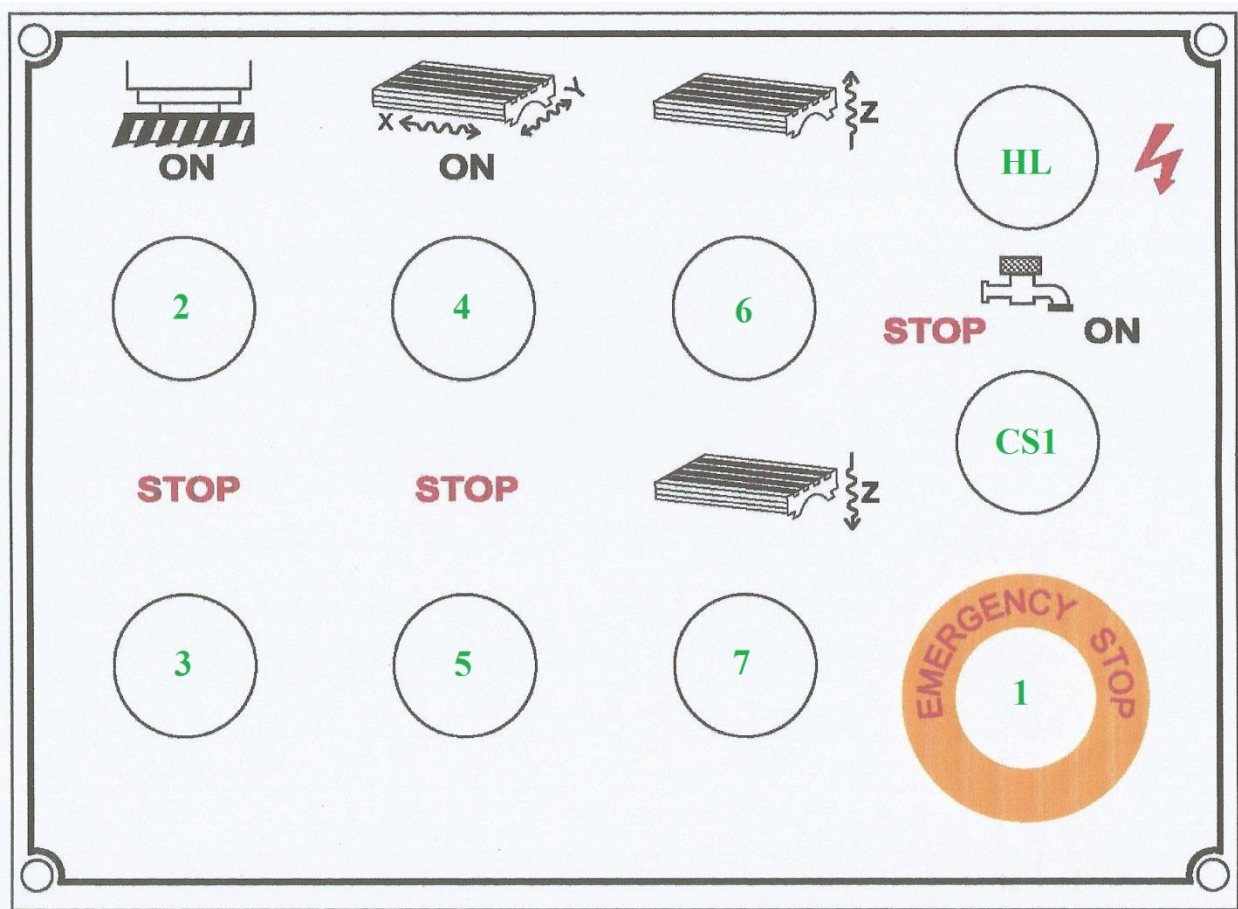

Description of Control Panel

1. Emergency Stop Switch
2. Spindle Start Switch
3. Spindle Stop Switch
4. X-Y Axis Start Switch
5. X-Y Axis Stop Switch
6. Up Start Button
7. Down Start Button

HL. Indicator Light Power

CS1. Coolant Switch On/Off

Second Operation Panel (Control Panel)

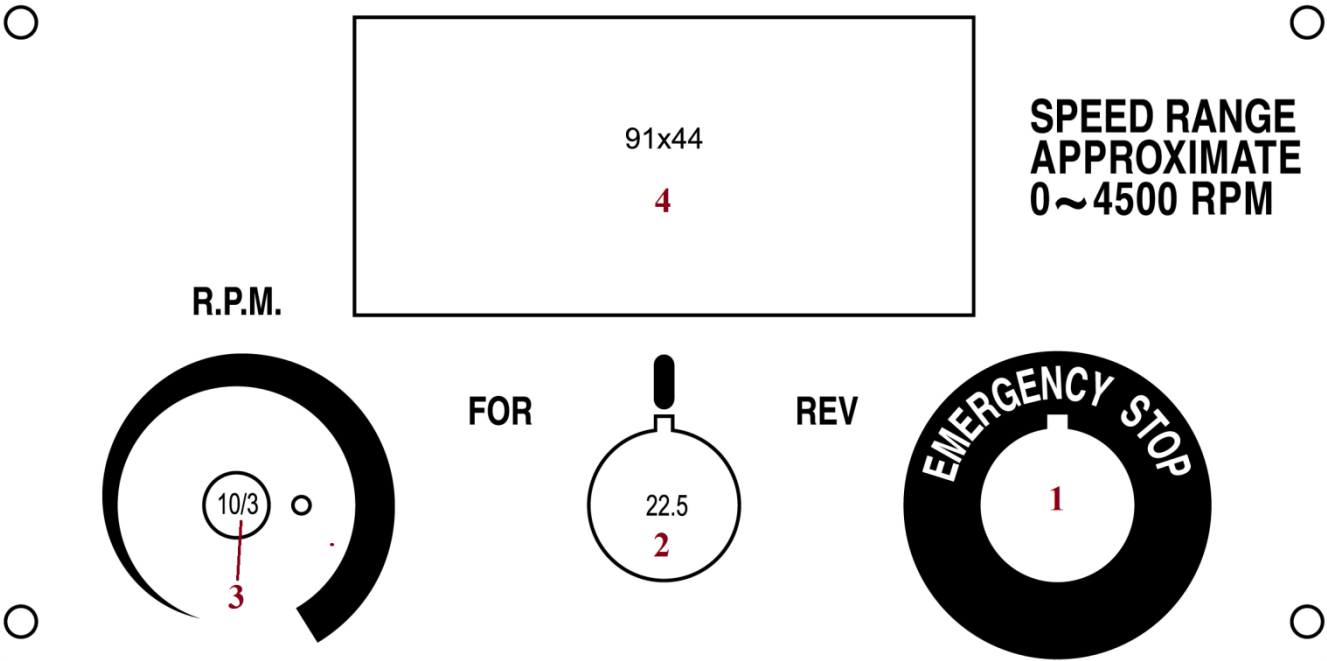

Item#	Part#	Description	QTY
1	9500	Emergency Switch	1
2	9501	F/R Switch	1
3	9502	Variable Resistor	1
4	9503-2	Digital Counter	1

Electric Cabinet Layout

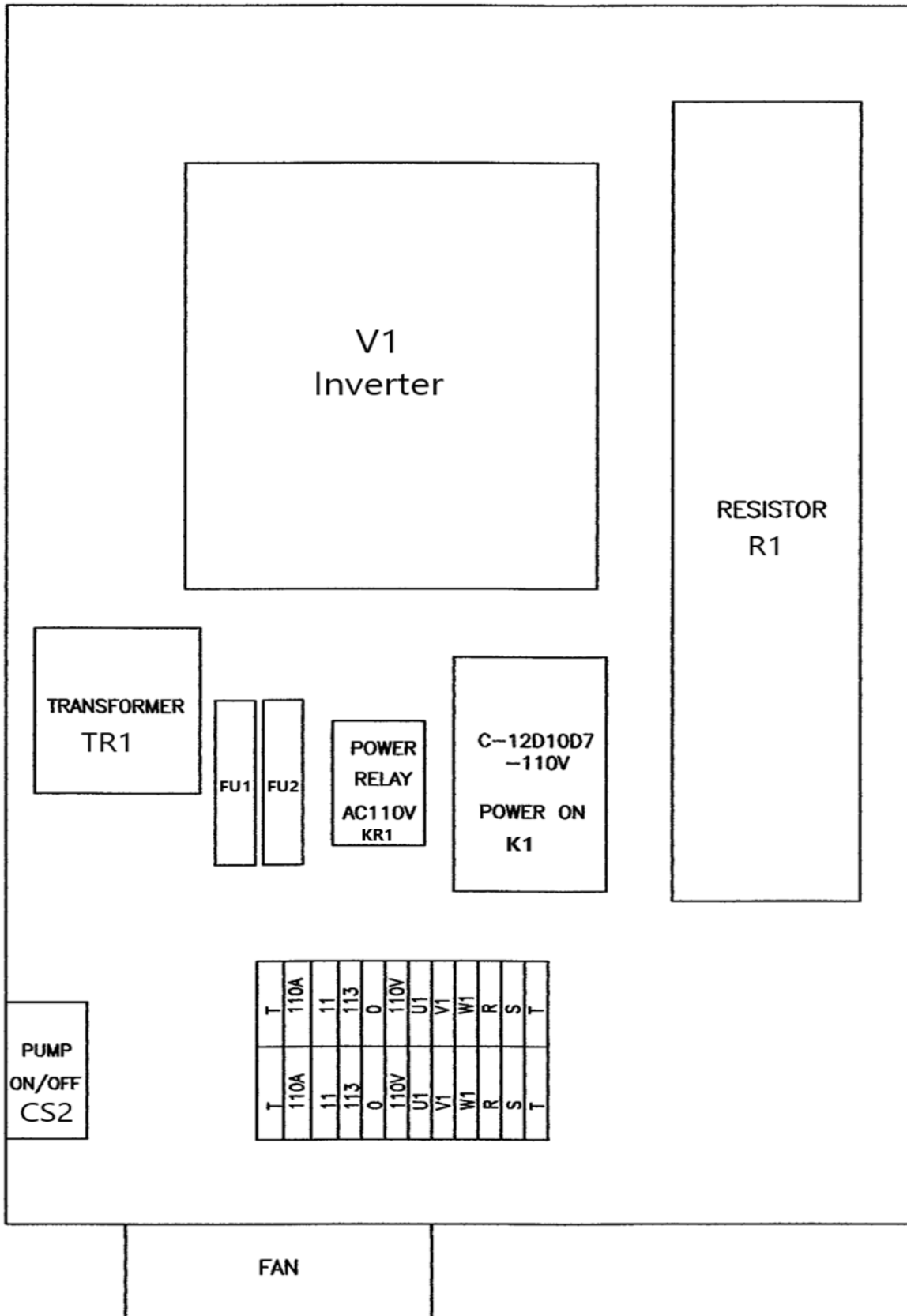

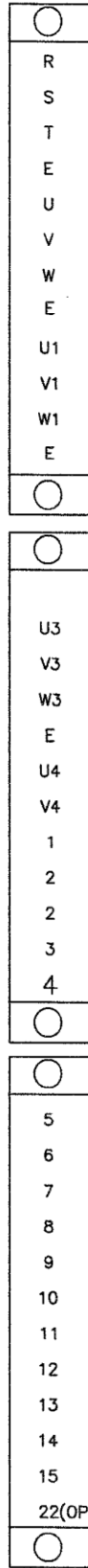
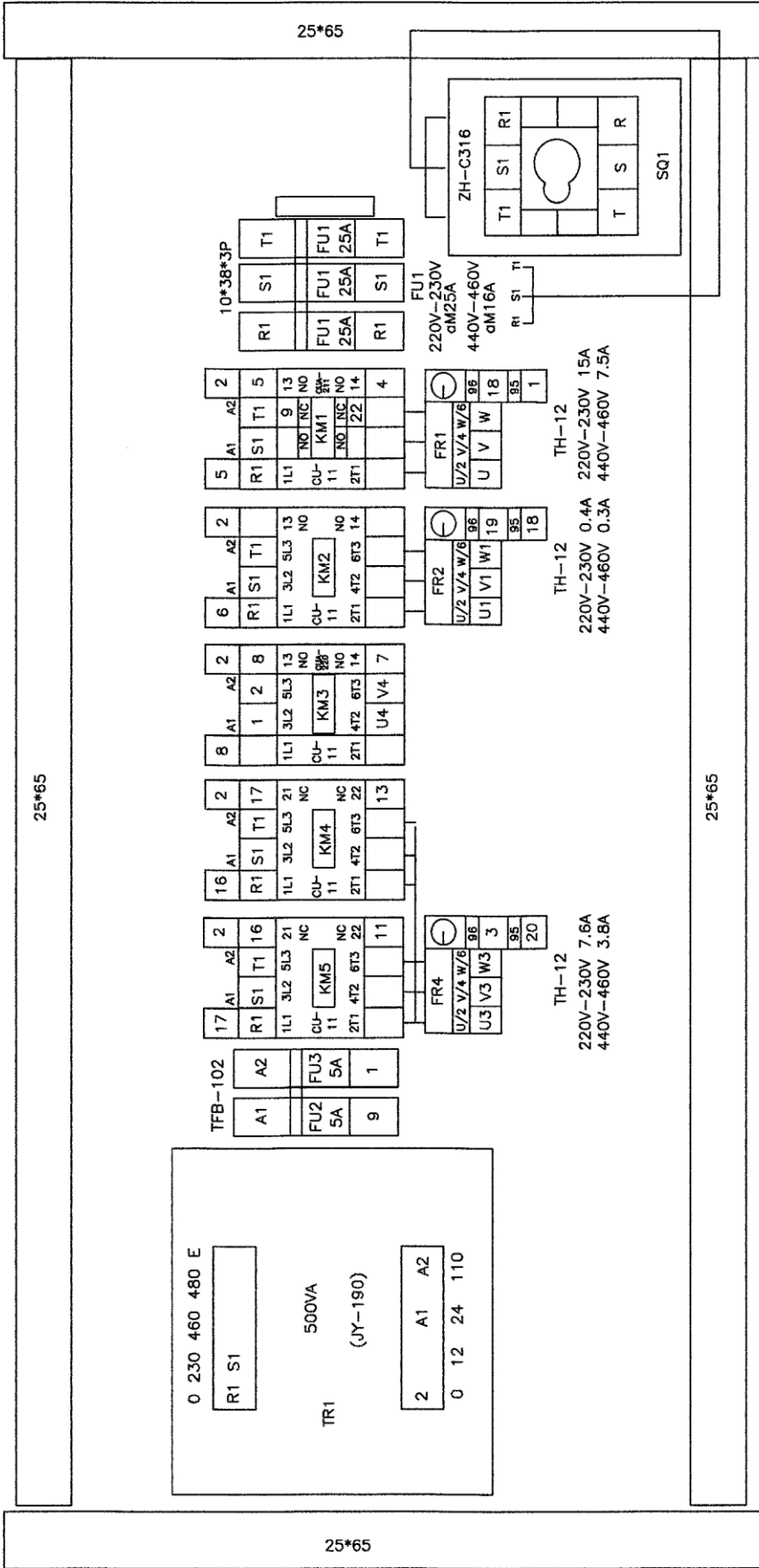

X1
25A*12P

X2
25A*12P

X3
25A*12P

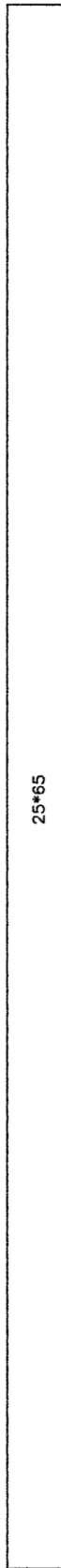

Electric Component List

	ACER	Model:	6VK 230/460V 5HP		
Item #	Description and function	Suppliers Reference	Technical data	Supplier	
1	TR1	Transformer	LCP-TBS JY- 270	500VA 0-480V/0-110V	LUNG GHI
2	SQ1	Supply disconnecting Switch	ZH-C316	440V 15KA/16A	KEDU
3	FU1	Fuse Blocks	RT18-32X	3P -600V/32A	CHANGXIN
4	FU2	Fuse Blocks	TFB-102	250V/10A	TEND
5	FU3	Fuse Blocks	TFB-102	250V/10A	TEND
6	FU1	Fuse	10*38*3P	500V-50KA/Am30a	CHANGXIN
7	FU2	Fuse	30mm	30mm/5A	TEND
8	FU3	Fuse	30mm	30mm/5A	TEND
9	KM1	Spindle Magnetic Contactor	CU-11/Coil 110V	230V/5HP/3KW	TECO
10	KM2	Coolant Magnetic Contactor	CU-11/Coil 110V	230V/5HP/3KW	TECO
11	KM3	X-Y axis Magnetic Contactor	CU-11/Coil 110V	230V/5HP/3KW	TECO
12	KM4	Up Magnetic Contactor	CU-11/Coil 110V	230V/5HP/3KW	TECO
13	KM5	Down Magnetic Contactor	CU-11/Coil 110V	230V/5HP/3KW	TECO
14	FR1	Spindle Overload Relay	TH-12	12-18A/230V(15A)	TENYU
15	FR2	Coolant Overload Relay	TH-12	0.9-1.5A/230V(0.9)	TENYU
16	FR4	Up/down Overload Relay	TH-12	7-10A/230V(7.6A)	TENYU
17	X1 X2 X3	Terminal Blocks	TB25-12P*3P	600V / 25A	TEND
18	PB1	Emergency stop switch	K2BS542	240V/3A/1B(R)	CHANGXIN
19	PB2	Spindle start Switch	K2BW33G1	240V/3A/1A(G)	CHANGXIN
20	PB3	Spindle stop Switch	K2BA42	240V/3A/1B(R)	CHANGXIN
21	PB4	X-Y axis stop Switch	K2BW33G1	240V/3A/1B(R)	CHANGXIN
22	PB5	X-Y axis start Switch	K2BA42	240V/3A/1A(G)	CHANGXIN
23	PB6	Up start Switch	K2BA21	240V/3A/1A(BK)	CHANGXIN
24	PB7	Down start Switch	K2BA21	240V/3A/1A(BK)	CHANGXIN
25	CS1	Coolant start/stop Switch	K2BD21	240V/3A/1A(BK)	CHANGXIN
26	HL	Indicator Light	NLD-22W	AC-110V (W)	NHD
27	LS1	Trip Spindle Limit Switch	TZ7311	10A 250VAC	TEND
28	LS2	Forward Limit Switch	KZ-5109	250V 15A	CHANGXIN
29	LS3	Reverse Limit Switch	KM-1308	250V 15A	CHANGXIN
30	LS4	Reverse Limit Switch	KM-1308	250V 15A	CHANGXIN
31	MS1	Spindle Motor	230V/460V 5HP	230V/460V 3.7KW	ACER
32	MS2	Coolant Motor	230V/460V 1/8HP	230V/460V 0.93KW	FLAIR
33	MS4	Up/down Motor	230V/460V 2HP	230V/460V 1.492KW	JIN-SHIN
34	EL	Halogen Light	HT-L81+GS-20	24V/70W	EGG
35	XS	X-Y axis power feed	LK 3021F	110V/2.5A	SKYEY
36	E-STOP	Emergency stop	S04509-RWA800FPMT34	690V 10A 4KV	Allen-Bradley
37	SB3	Emergency stop	S04509-RWA800FPMT35	690V 10A 4KV	Allen-Bradley
38	LIMIT SW	Spindle Stop Limit Switch	TZ7311	10A 250VAC	TEND
39	LIMIT SW	HI/LOW gear Limit Switch	SHL-Q2255 AC-15 2A 125V	2A 125V	OMRON
40	SB1	FORWARD SWITCH	S04509-RWA800FPMT32	690V 10A 4KV	Allen-Bradley
41	SB2	REVERSE SWITCH	S04509-RWA800FPMT32	690V 10A 4KV	Allen-Bradley
42	R.P.M METER	RPM DIGITAL COUNTER	PWRMMX-1-A13A	DC0-10V 0~5300/660RPM	PWR
43	V1	TOSHIBA S15 INVERTER	VF-S15	230V/460V/3P/3.7KW	Toshiba
44	V1	FRN0020E2S-2GB	FRN0020E2S-2GB	230V/460V/3P/3.7KW	Fuji
45	R1	Braking Resistors	ZQR450W 6.5Ω x 3	1350W	Toshiba
46	R1	Braking Resistors	ZQR450W 11Ω x 3	1350W	Fuji
47	TR 1	Single Phase Transformer	1Q24VA	24VA	Chen-Ten Electronics
48	F1	Circuit Breaker		3A	TEND
49	F2	Circuit Breaker		3A	TEND
50	Power Relay	Power Relay 110V	MY-2NJ+PYF-08A-E-T OMZ	5A 250VAC	OMRON
51	Power On	Power On Contactor	C12D10D7	220V 3P 5.5HP	NHD
52	CS2	Coolant On/Off Button		3P 10A 500V 2.2KW	Suen-An
53	FAN	Cooling Fan	GA1123XBL	AC110/120V 18/19W	Gulf Electronics
54	B202 2K	Variable Resistor	B202 2K	2kΩ	JASON
55	LUB 110V	Lubrication Pump	CESMA-2L	110V/0.1A/4W	CHEN-YING

C. UL Electric Diagram for 3VS, 3VSII, 3VK, 3VKH, 5VK

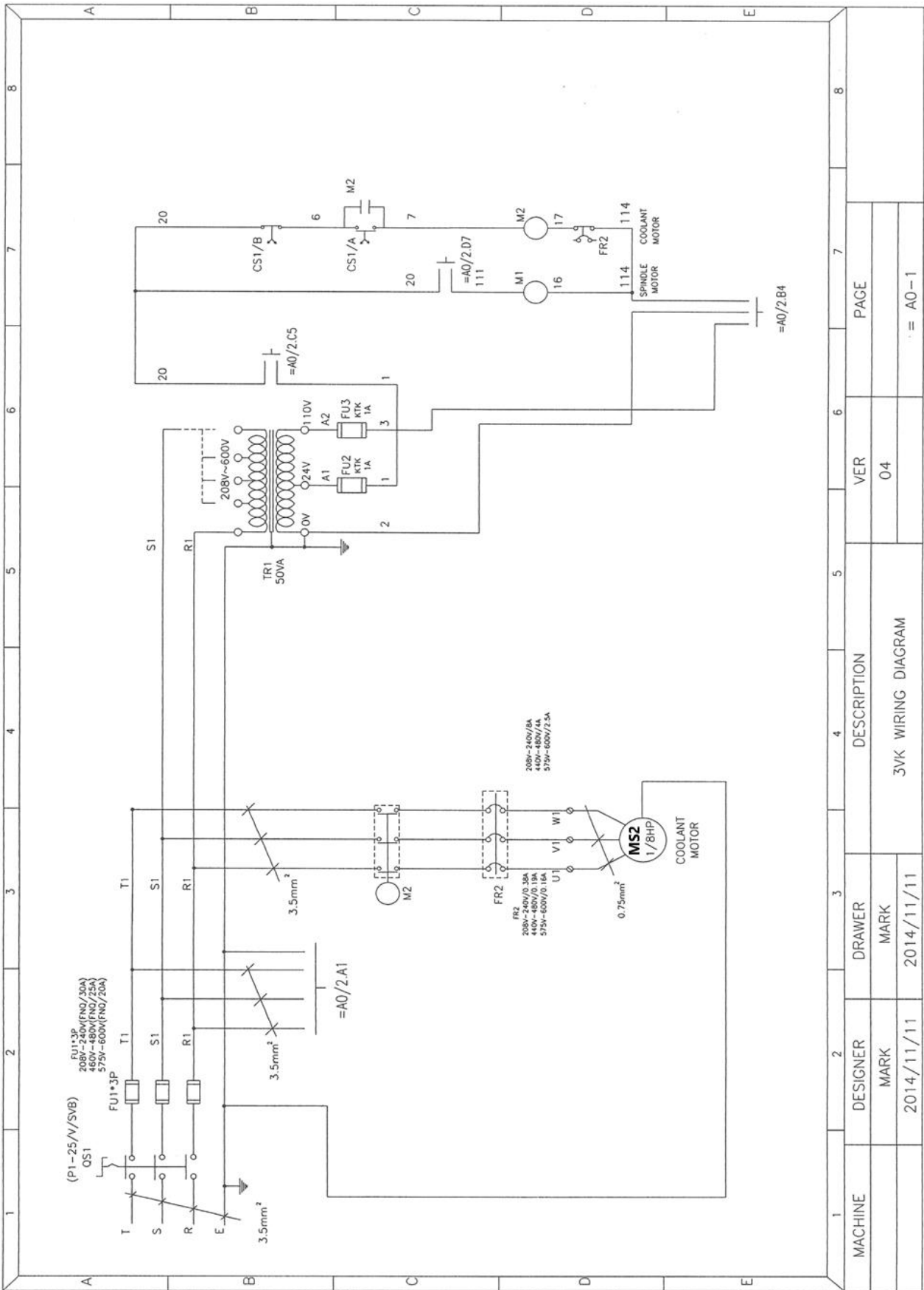

MACHINE	DESIGNER	DRAWER	DESCRIPTION	VER	PAGE
	MARK	MARK	3VK WIRING DIAGRAM	04	
	2014/11/11	2014/11/11			AO-1

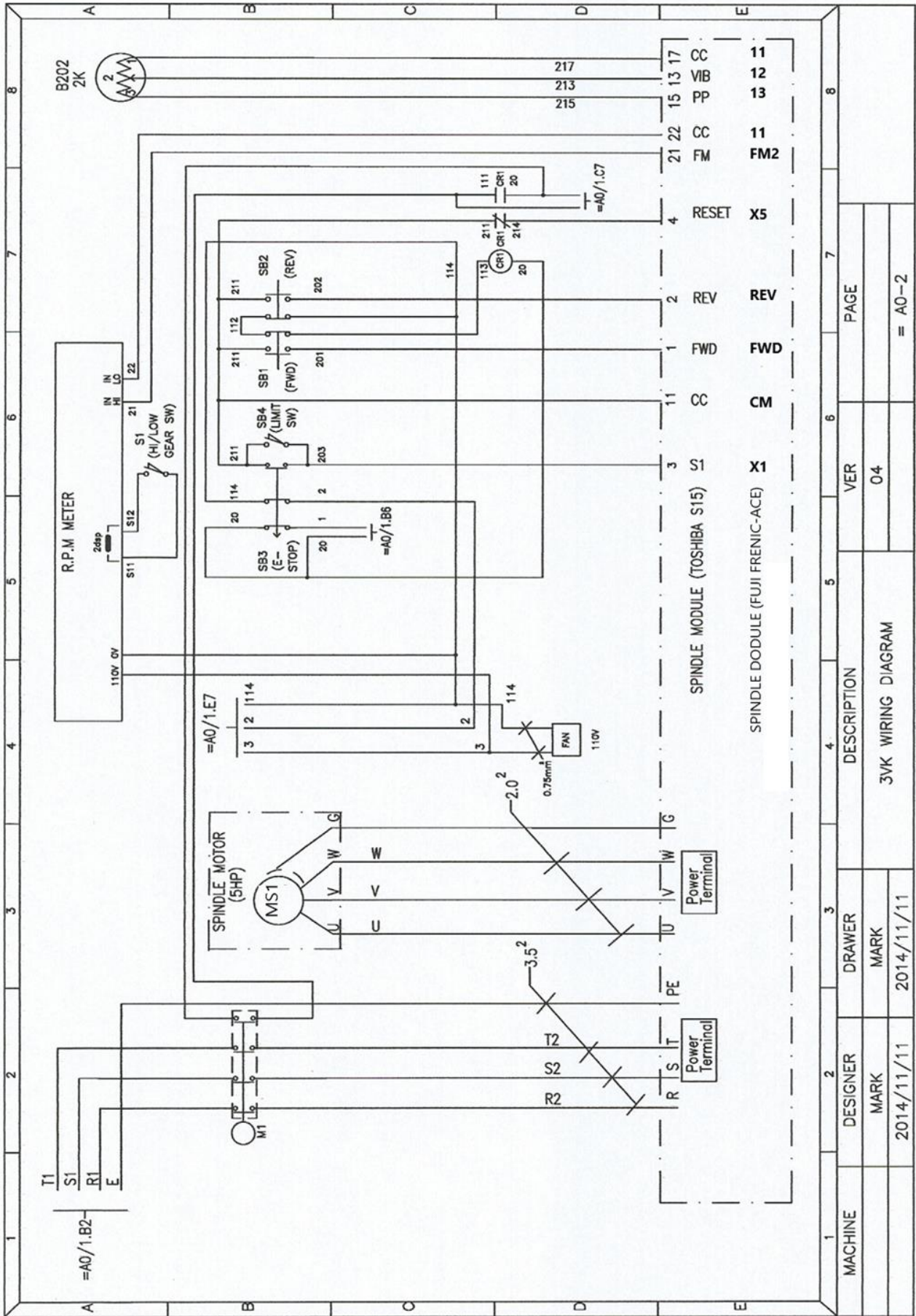

MACHINE	DESIGNER	DRAWER	DESCRIPTION	VER	PAGE
	MARK	MARK	3VK WIRING DIAGRAM	O4	
	2014/11/11	2014/11/11			= A0-2

Control Panel

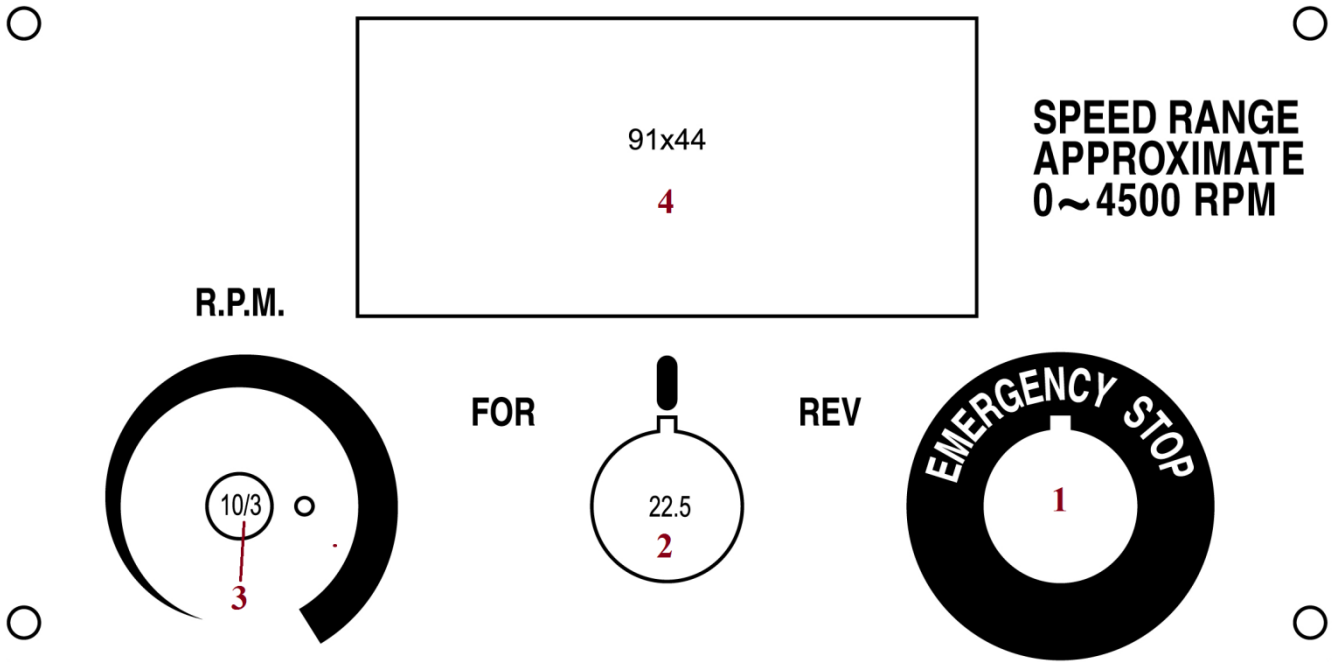

Item#	Part#	Description	QTY
1	9500	Emergency Switch	1
2	9501	F/R Switch	1
3	9502	Variable Resistor	1
4	9503-2	Digital Counter	1

Input power at 230V/3P/60HZ, the power disconnect breaker is at 25A, wiring must be 3.5mm² or greater.

Input power at 460V/3P/60HZ, the power disconnect breaker is at 20A, wiring must be 3.5mm² or greater.

Electric Cabinet Layout

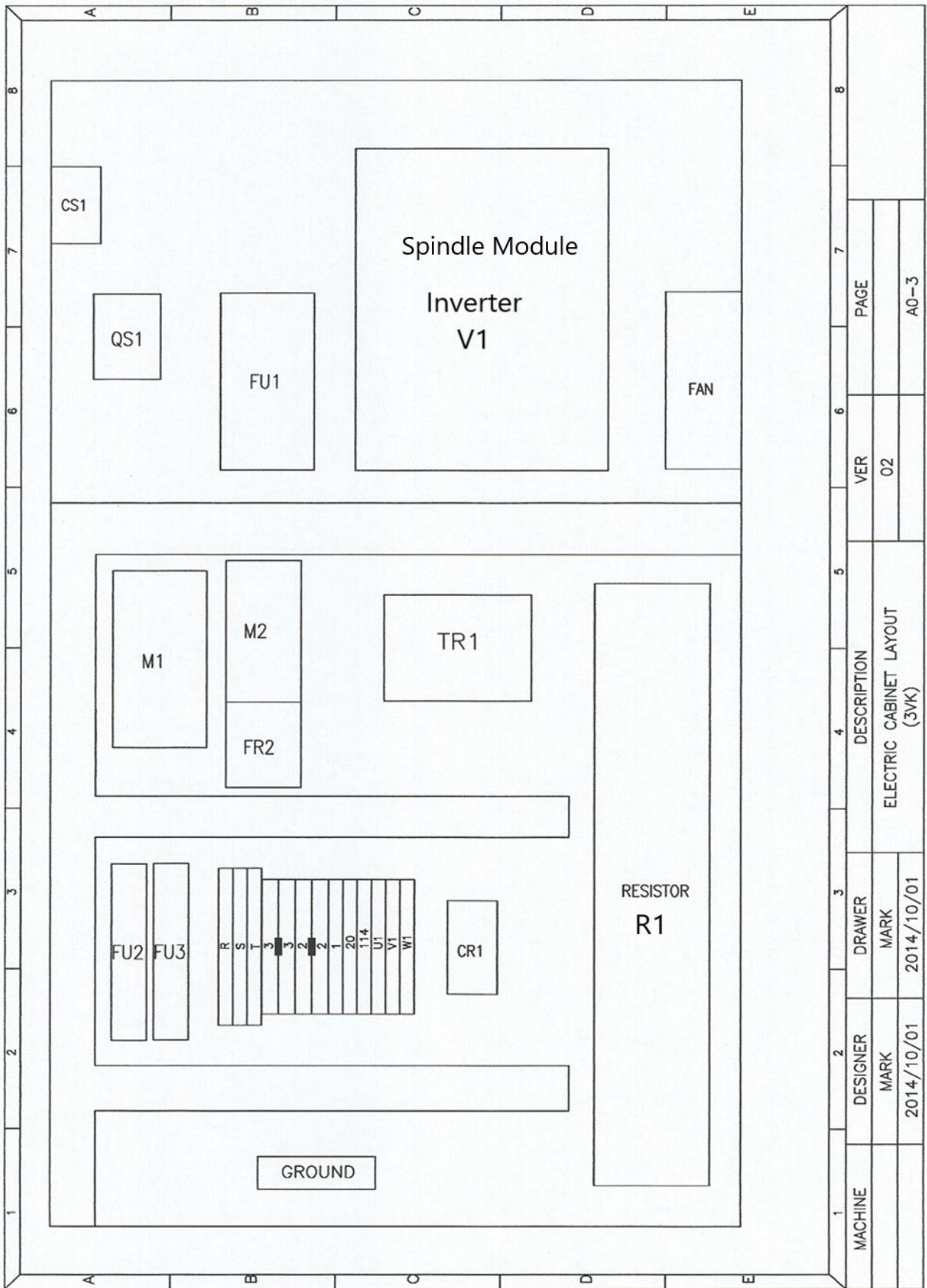

1	2	3	4	5	6	7	8
MACHINE	DESIGNER MARK	DRAWER MARK	DESCRIPTION ELECTRIC CABINET LAYOUT (3VK)		VER 02	PAGE	A0-3
	2014/10/01	2014/10/01					

Electric Component List

PARTS NUMBER IN CIRCUIT DIAGRAM	PARTS NAME	MAKER	PARTS CATALOG NUMBER	QTY	UL No.	UL File
QS1	Main Switch	EATON	TO-2-1/V/SVB	1	E36332	UL508
	Relay Seat	OMRON	PYF-08A-E-T OMZ	1	E41515	
CR1	Relay	OMRON	MY-2NJ AC24V	1	E41515	
SPINDLE MODULE	TOSHIBA S15 INVERTER	Toshiba Electric System	VF-S15	1	E204788	
SPINDLE MODULE	FRN0020E2S-2GB	Fuji	FRN0020E2S-2GB	1	E132902	
R1	Braking Resistors	Toshiba Electric System	ZQR450W 6.5Ω	3		
R1	Braking Resistors	Fuji	ZQR450W 11Ω	3		
FU1	Circuit Breaker	EATON (Moeller)	FAZ-C20/3-NA/1	1	E177451	
FU2,FU3	Circuit Breaker	EATON (Moeller)	FAZ-S1/1	2	E177451	
M1	Contacto	EATON (Moeller)	DILM17-01 A4/AC24V	1	E29096	
M2	Contacto	EATON (Moeller)	DILM9-01 A4/AC24V	1	E29096	
FR2	Thermal Over Load Relay	Moeller	ZB12-0.6	1	E29096	
	Terminal Block	Wago	2002-1301/3C 2.5mm	12	E45172	04CA08683
	Terminal Block	Wago	2004-1301	3	E45172	05CA06105
	Terminal End	Wago	2002-1392/3C 2.5mm	5	E45172	04CA08683
	Terminal End	Wago	2004-1391/Grey	1	E45172	05CA06105
SB4	Limit Switch	Azbil	LCB1-501	1	E81046	
S1	Limit Switch	OMRON	SHL-Q2255	1	E76675	
PB5	Push Button	Allen-Bradley	800FP-SM22/800F-ALP/800F-X10	1	E338755+E14840	UL508
MS1	Spindle Motor	Min-Loon Electrical Engineering	AEVF	1	E222265	
FAN	Cooling Fan	Gulf Electrics Co.	GA1123XBL	1	E330961	
TR 1	Control Transformer	LUNG CHI ELECTRIC CO	TS01C-50VA	1	E323396	
R.P.M METER	RPM DIGITAL COUNTER	PWR	PWRMMX-1-A13A+C	1	CE only	EC48C010
SB1	FORWARD SWITCH	Allen-Bradley	800FP-SM22/800F-ALP/800F-X10	1	E338755+E14840	UL508
SB2	REVERSE SWITCH	Allen-Bradley	800FP-SM22/800F-ALP/800F-X10	1	E338755+E14840	UL508
SB3	EMERGENCY SWITCH	Allen-Bradley	800FP-SM22/800F-ALP/800F-X10	1	E338755+E14840	UL508
B202 2K	Variable Resistor	JASON	2kΩ	1		
	Fan Filter	Etek Chang Sing Enterprise	F4; test to IP degree 54 at TUV	1	Ak50242179 0001	E56070
	Cable	YI HUAN	0.5*1C White		1015	E250011
	Cable	YI HUAN	0.75*1C White		1015	E250011
	Cable	YI HUAN	0.75*1C Red		1015	E250011
	Cable	YI HUAN	1.25*1C White		1015	E250011
	Cable	YI HUAN	1.25*1C Red		1015	E250011
	Cable	YI HUAN	2.0*1C Black		1015	E250011
	Cable	YI HUAN	3.5*1C Black		1015	E250011
	Cable	YI HUAN	22AWG*1P Grey	2464		E250011
	Cable Conduit & Fitting	Kai Suh Suh Enterprise	HD-3, HD-4, HD-5.7		E97527	

D. UL Electric Diagram for 6VK

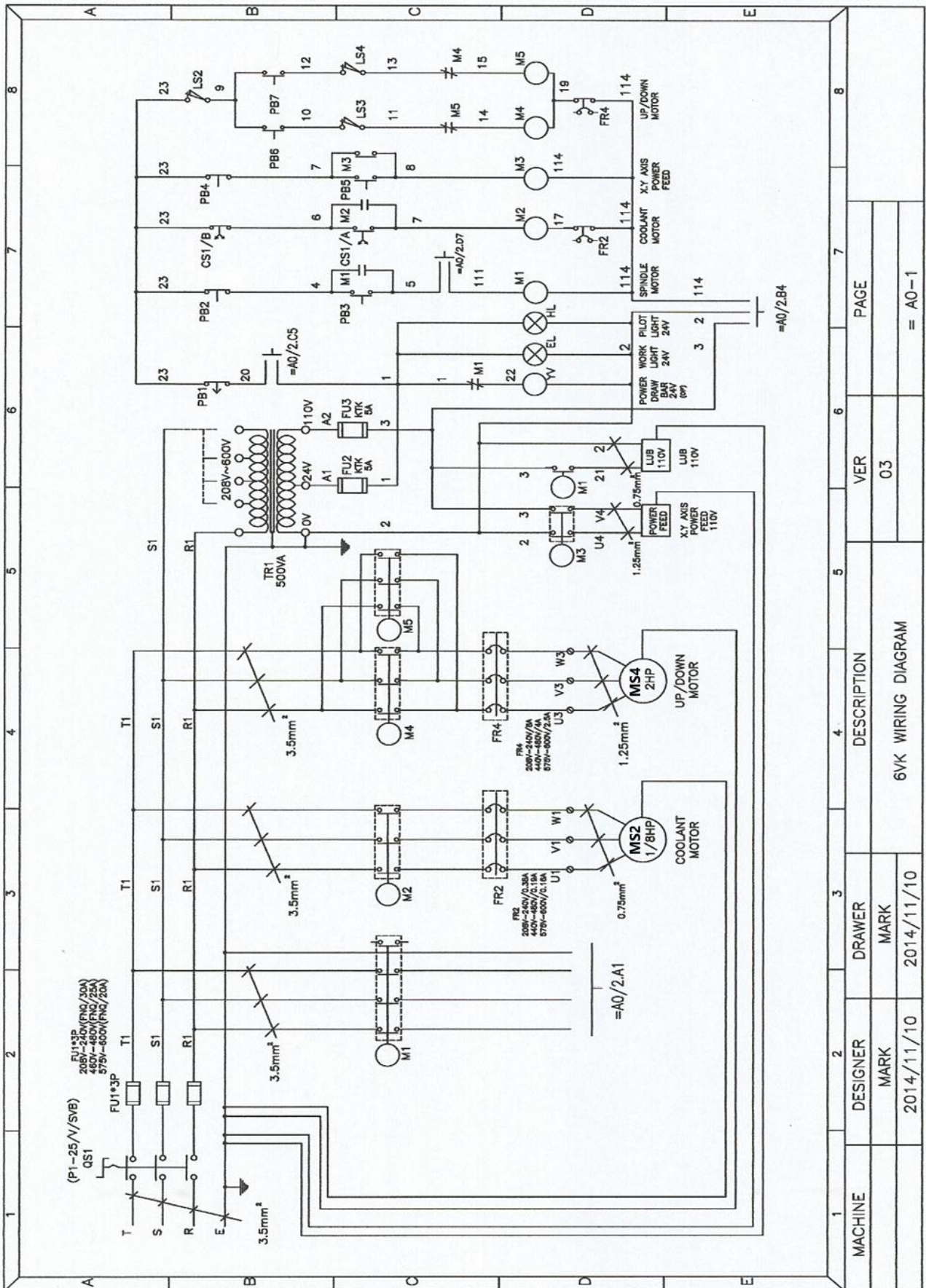

MACHINE	DESIGNER	DRAWER	DESCRIPTION	VER	PAGE
	MARK	MARK	6VK WIRING DIAGRAM	0.3	
	2014/11/10	2014/11/10			= A0-1

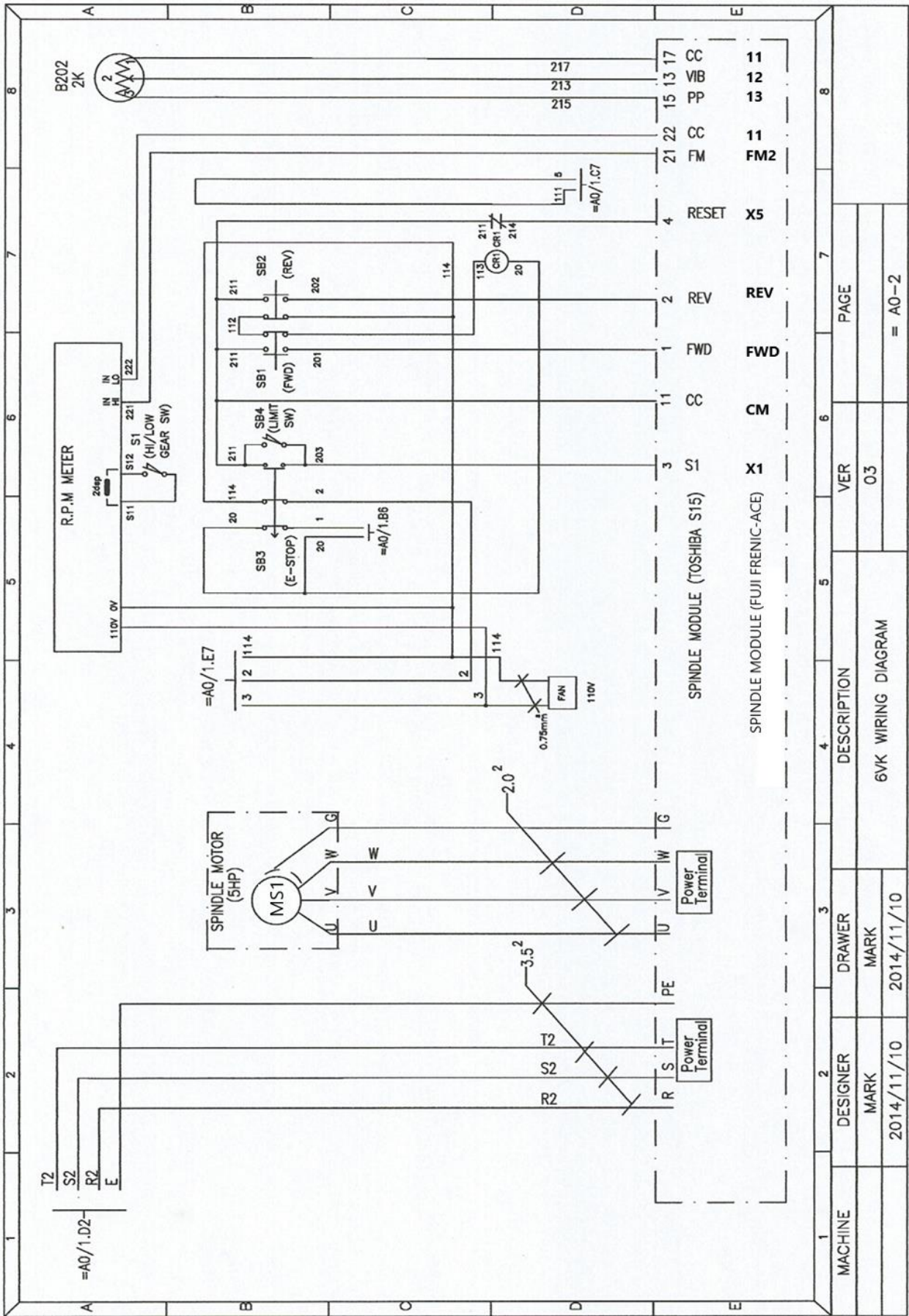

MACHINE	DESIGNER	DRAWER	DESCRIPTION	VER	PAGE
	MARK	MARK	6VK WIRING DIAGRAM	03	
	2014/11/10	2014/11/10			= A0-2

Operation Panel

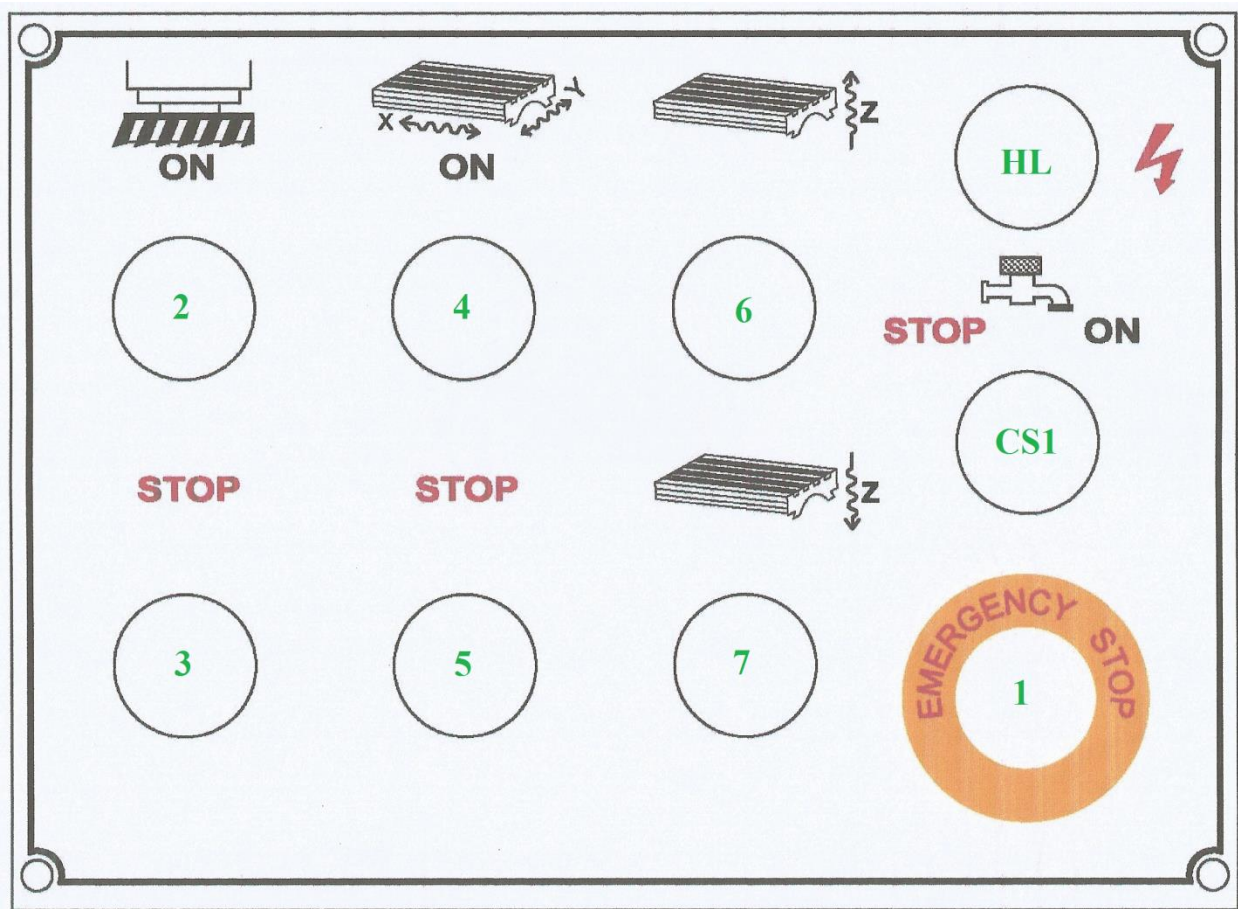

Description of Operation Panel

1. Emergency Stop Switch
2. Spindle Start Switch
3. Spindle Stop Switch
4. X-Y Axis Start Switch
5. X-Y Axis Stop Switch
6. Up Start Button
7. Down Start Button

HL. Indicator Light Power

CS1. Coolant Switch On/Off

Input power at 230V/3P/60HZ, the power disconnect breaker is at 25A, wiring must be 3.5mm² or greater.

Input power at 460V/3P/60HZ, the power disconnect breaker is at 20A, wiring must be 3.5mm² or greater

Second Operation Panel (Control Panel)

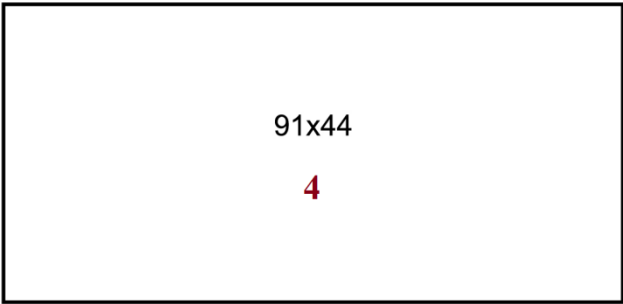

**SPEED RANGE
APPROXIMATE
0~4500 RPM**

R.P.M.

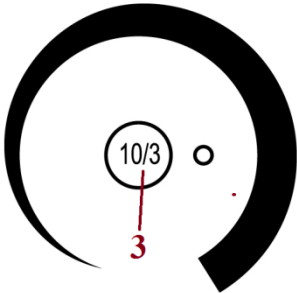

FOR

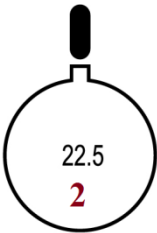

REV



Item#	Part#	Description	QTY
1	9500	Emergency Switch	1
2	9501	F/R Switch	1
3	9502	Variable Resistor	1
4	9503-2	Digital Counter	1

Electric Cabinet Layout

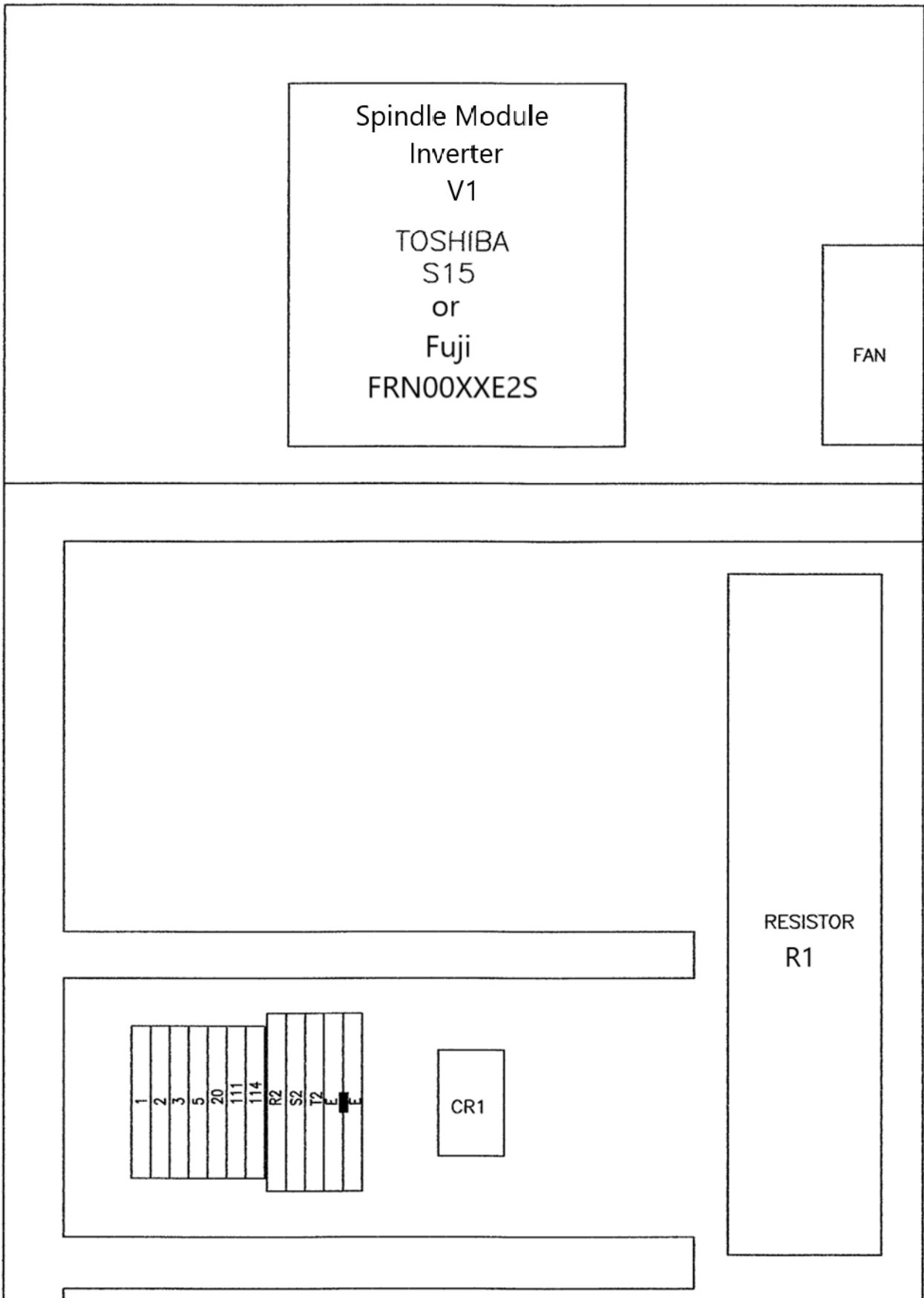

Electric Component List

PARTS NUMBER	PARTS NAME	MAKER	PARTS CATALOG NUMBER	QTY	UL No.	UL File
IN						
PB1	Emergency Switch	SCHNEIDER	XB5-AS542/240V/3A/1B (RED)	1	E164353	
PB2	Spindle Start Switch	SCHNEIDER	XB5-AW33B1/240V/3A/1A (GED)	1	E164353	
PB3	Spindle Stop Switch	SCHNEIDER	XB5-AA42/240V/3A/1B (RED)	1	E164353	
PB4	X-Y Axis Stop Switch	SCHNEIDER	XB5-AA42/240V/3A/1B (RED)	1	E164353	
PB5	X-Y Axis Start Switch	SCHNEIDER	XB5-AW33B1/240V/3A/1A (GED)	1	E164353	
PB6	Start Switch-Up	SCHNEIDER	XB5-AA21/240V/3A/1A (BLACK)	1	E164353	
PB7	Start Switch-Down	SCHNEIDER	XB5-AA21/240V/3A/1A (BLACK)	1	E164353	
CS1	Coolant On/Off Switch	SCHNEIDER	XB5-AD21/240V/3A/1A (BLZCK)	1	E164353	
TR1	Transformer	LUNG GHI	LCP-TBS JY- 270/500VA 0-480V/0-	1	E323396	
QS1	Supply Disconnecting Switch	EATON	PI-25V/SVB/600V 10KA/25A	1	20100923-E36332	
FR2	Coolant Overload Relay	SCHNEIDER	LR3D03/0.25-0.4A/0.38A	1	E164353	
FR4	Up/Down Overload Relay	SCHNEIDER	LR3D14/7-10A/8A	1	E164353	
FU1	Fuse Blocks	BUSSMANN	10*38*3P/3P -600V/32A	1	053787-C-000	
FU2	Fuse Blocks	BUSSMANN	10*38*1P/1P -600V/32A	1	053787-C-000	
FU3	Fuse Blocks	BUSSMANN	10*38*1P/1P -600V/32A	1	053787-C-000	
FU1	Fuse	BUSSMANN	FNQ/30A/3P-600A/20KA	3	053787-C-000	
FU2	Fuse	BUSSMANN	ST2.5 - TWIN 3031241/1P-600A/20KA	1	053787-C-000	
FU3	Fuse	BUSSMANN	ST2.5 - TWIN 3031241/1P-600A/20KA	1	053787-C-000	
KM1	Spindle Magnetic Contactor	SCHNEIDER	LC1D18 B7/COIL AC-24V	1	043364-S-000	
KM2	Coolant Magnetic Contactor	SCHNEIDER	LC1D09 B7/COIL AC-24V	1	043364-S-000	
KM3	X-Y Axis Magnetic Contactor	SCHNEIDER	LC1D09 B7/COIL AC-24V	1	043364-S-000	
KM4	Magnetic Contactor-Up	SCHNEIDER	LC1D09 B7/COIL AC-24V	1	043364-S-000	
KM5	Magnetic Contactor-Down	SCHNEIDER	LC1D09 B7/COIL AC-24V	1	043364-S-000	
X1	Terminal Blocks	PHOENIX	MSB2.5-MS35/600V / 20A	1	13631 0 000	
RI, S1, T1, E	Main Circuit Wires	ZHAO TAI	3.5mm-12AWG-105°C600V	1	2397459	
U3, V3, W3, U4, V4	Control Loop Wire	ZHAO TAI	1.25mm-16AWG-105°C600V	1	2397459	
U1,V1, W1, 21, 2	Signal Wire	ZHAO TAI	0.75mm-18AWG-105°C600V	1	2397459	
HL	Indicator Light	SCHNEIDER	XB7-EV6/LED AC-24V(WHITE)	1	E164353	
LS2	Forward Limit Switch	MOUJEN	MJ-7103B/250V/15A	1	E100182	
LS3	Reveres Limit Switch	MOUJEN	TM-1308/250V/15A	1	E130631	
LS4	Reveres Limit Switch	MOUJEN	TM-1308/250V/15A	1	E130631	
MS1	Spindle Motor	MING-LOOUN	AC-230V/460V-5HP/3.7KW	1	E222265	
MS4	Up/Down Motor	JIN SHIN	AC-230V/460V-2HP/1.492KW	1	E363171	
MS2	Coolant Motor	Taiwan Chang Steel Electric	MC-8180/AC230/460V	1	208361-1148030	
POWER FEED	X-Y Axis Power Feed	ALIGN	AC-110V/90W	2	121154R-ITCEP14V01	
EL	Work Light	GOLDEN	G-L80/AC-24V/70W	1	11035558-001	
LUB 110V	Lubrication Pump	CHEN-YING	CESMA-2L 110V/0.1A/4W	1	AE 50180342 0001	
	Cable Conduits & Fittings	KAI SUH SUH ENTERPRIS	HD-3, HD-4, HD-5.7		E97527	

PARTS NUMBER IN CIRCUIT	PARTS NAME	MAKER	PARTS CATALOG NUMBER	QTY	UL No.	UL File
R.P.M METER	Digital R.P.M Meter	PWR	PWRMMX-1-A13A	1	EM/2000/30055	
E-STOP	Emergency Stop	Rockwell Automation/Allen Bradley	S04509-RWA800FPMT34	1	E338755/E14840	
SB3	Emergency Stop	Rockwell Automation/Allen Bradley	S04509-RWA800FPMT35	1	E338755/E14840	
SB4	LIMIT Switch	Azbil	LCB1-501 10A 250VA	1	E81046	
S1	HI/LOW GEAR SW	OMRON	SHL-Q2255 AC-15 2A 125V	1	E76675	
SB1	Switch Forward	Rockwell Automation/Allen Bradley	S04509-RWA800FPMT32	1	E338755/E14840	
SB2	Switch Reverse	Rockwell Automation/Allen Bradley	S04509-RWA800FPMT32	1	E338755/E14840	
FAN	Cooling Fan	GULF	GA1123XBL AC110/120V 18/19W	1	E330961	
	Relay Seat	OMRON	PYF-08A-E-T OMZ	1	E41515	
CR1	Relay	OMRON	MY-2NJ AC24V	1	E41515	
Spindle Module	Inverter	Toshiba or Fuji	VF-S15 or Fuji FRENIC-ACE	1	E204788/E132902	
	Braking Resistors	Toshiba or Fuji	ZQR450W	3		
	Terminal Block	Wago	2002-1301/3C 2.5mm	7	E45172	04CA08683
	Terminal Block	Wago	2004-1307	2	E45172	05CA06105
	Terminal Block	Wago	281-681	3	E45172	79ME9232
	Terminal End	Wago	2002-1392/3C 2.5mm	3	E45172	04CA08683
	Terminal End	Wago	2004-1391/Grey	1	E45172	05CA06105
	Terminal End	Wago	281-324	1	E45172	79ME9232
B202 2K	Variable Resistor	JASON	2kΩ	1		
	Screwless End		INTBR-F/ Grey	2		
	Fan Filter	Etek Chang Sing Enterprise	F4; test to IP degree 54 at TUV	1	Ak50242179 000	E56070
3	Cable	YI HUAN	0.5*1C White		1015	E250011
	Cable	YI HUAN	0.75*1C White		1015	E250011
2	Cable	YI HUAN	0.75*1C Red		1015	E250011
	Cable	YI HUAN	1.25*1C White		1015	E250011
	Cable	YI HUAN	1.25*1C Red		1015	E250011
U, V, W, G	Cable	YI HUAN	2.0*1C Black		1015	E250011
R2, S2, T2	Cable	YI HUAN	3.5*1C Black		1015	E250011
	Cable	YI HUAN	22AWG*IP Grey		2464	E250011
	Cable Conduit & Fitting	Kai Suh Suh Enterprise	HD-3, HD-4, HD-5.7		E97527	

E. Electrical Part List with Part Number Listed

Regular electrical part list for e-mill 3VS, 3VSII, 3VK, 3VKH, 5VK, 6VK

Part #	Item #	Description and function	ACER	Model:	3VS, 3VSII, 3VK, 3VKH, 5VK, 6VK	Suppliers Reference	QTY
9500	E-STOP	Emergency Stop	Allen Bradley	Technical data	S04509-RWA800FPMT34	1	
9500	SB3	Emergency Stop	Allen Bradley	Technical data	S04509-RWA800FPMT35	1	
9505-1	LIMIT SW	SPINDLE STOP LIMIT SWITCH	TEND	Technical data	TZ7311	1	
9555	LIMIT SW	HI/LOW GEAR SWITCH	OMRON	Technical data	SHL-Q2255 AC-15 2A 125V	1	
9501	SB1	Switch Forward	Allen Bradley	Technical data	S04509-RWA800FPMT32	1	
9501	SB2	Switch Reverse	Allen Bradley	Technical data	S04509-RWA800FPMT32	1	
9503-2	R.P.M METER	Digital R.P.M Meter	PWR ELECTRONICS	Technical data	PWRMMX-1-A13A	1	
9507-10	S15 Inverter	Inverter	Toshiba	Technical data	VF-S15	1	
9507-11	S15 Inverter	Inverter	Toshiba	Technical data	VF-S15	1	
9507-16	FRN0020E2S-2GB	Inverter	Fuji	Technical data	FRN0020E2S-2GB	1	
9507-17	FRN0012E2S-4GB	Inverter	Fuji	Technical data	FRN0012E2S-4GB	1	
9506-10	Resistor R1	Braking Resistors		Technical data	ZQR450W6.5J	3	
9506-11	Resistor R1	Braking Resistors		Technical data	ZQR450W20J	3	
9506-16	Resistor R1	Braking Resistors		Technical data	ZQR-450W/11Ω	3	
9506-17	Resistor R1	Braking Resistors		Technical data	ZQR-450W/43.3Ω	3	
9512	Transformer	Single Phase Transformer	Cheng-Ten Electronics	Technical data	1Q24VA	1	
9512-1	Transformer	Single Phase Transformer	Cheng-Ten Electronics	Technical data	1Q24VA	1	
9700	F1	Fuse 1	TEND	Technical data	3A	1	
9700	F2	Fuse 2	TEND	Technical data	3A	1	
9514	Power Relay	Power Relay 110V	OMRON	Technical data	MY2N-J	1	
9507-4	Power On	Power On Contactor	NHD	Technical data	C12D10D7 24V	1	
9511	ON/OFF	Coolant On/Off Button	SUEN-AN	Technical data	3P 10A 500V 2.2KW	1	
9510-2	Fan	Cooling Fan	Gulf Electronics	Technical data	AC110/120V 18/19W	1	
9502	VR	Variable Resistor	JASON	Technical data	2K Ohms	1	
9570-1	TR1	Transformer	LUNG GHI	Technical data	500VA 0-480V/0-110V	1	
9701	SQ1	Supply Disconnecting Switch	KEDU	Technical data	440V 15KA 16A	1	
9702	FU1	Fuse Blocks	CHANGXIN	Technical data	3P-500V/32A	1	
9703	FU2	Fuse Blocks	TEND	Technical data	250V/10A	1	
9703	FU3	Fuse Blocks	TEND	Technical data	250V/10A	1	
9704	FU1	Fuse	CHANGXIN	Technical data	500V-50KA/aM30A	1	
9705	FU2	Fuse	TEND	Technical data	30mm/5A	1	
9705	FU3	Fuse	TEND	Technical data	30mm/5A	1	
9706	KM1	Spindle Magnetic Contactor	TECO	Technical data	230V / 5HP /3KW	1	
9706	KM2	Coolant Magnetic Contactor	TECO	Technical data	230V / 5HP /3KW	1	

Part #	Item #	ACER	Description and function	Supplier	Model:	Technical data	Suppliers Reference	QTY
9706	KM5		Down Magnetic Contactor	TECO	3VS, 3VSII, 3VK, 3VKH, 5VK, 6VK	230V / 5HP /3KW	CU-11 /Coil 110V	1
9707	FR1		Spindle Overload Relay	TENYU		12-18A/230V(15A)	TH-12	1
9708	FR2		Coolant Overload Relay	TENYU		0.9-1.5A/ 230V(0.9A)	TH-12	1
9709	FR4		Up/down Overload Relay	TENYU		7-11A/230V(7.6A)	TH-12	1
9710	X1 X2 X3		Terminal Blocks	TEND		600V / 25A	TB25-12P*3P	1
9711	PB1		Emergency Stop switch	CHANGXIN		250V/6A/1B(R)	K2BS542	1
9712	PB2		Spindle Start Switch	CHANGXIN		250V/6A/1A /110V(G)	K2BW33G1	1
9711	PB3		Spindle Stop Switch	CHANGXIN		250V/6A/1B(R)	K2BA42	1
9712	PB4		X-Y Axis Start Switch	CHANGXIN		250V/6A/1A /110V(G)	K2BW33G1	1
9711	PB5		X-Y Axis Stop Switch	CHANGXIN		250V/6A/1B(R)	K2BA42	1
9713	PB6		Up Start Switch	CHANGXIN		250V/6A/1A(BK)	K2BA21	1
9713	PB7		Down Start Switch	CHANGXIN		250V/6A/1A(BK)	K2BA21	1
9713	CS1		Coolant Start/Stop Switch	CHANGXIN		250V/6A/1A(BK)	K2BD21	1
9714	HL		Indicator Light	NHD		AC-110V (W)	NLD-22 W	1
9715	LS1		Trip Spindle Limit Switch	TEND		10A 250VAC	TZ7311	1
9716	LS2		Forward Limit Switch	CHANGXIN		250V 15A	KZ-5109	1
9716	LS3		Reverse Limit Switch	CHANGXIN		250V 15A	KM-1308	1
9716	LS4		Reverse Limit Switch	CHANGXIN		250V 15A	KM-1308	1
8008-1	MS1		Spindle Motor	MING-LOOUN		AC-230V/460V-3HP/2.25KW	AEVF	1
5E8008-1	MS1		Spindle Motor	MING-LOOUN		AC-230V/460V-5HP/3.75KW	AEVF	1
9590	MS2		Coolant Pump Motor	Option		1/8HP 3P 230/460V		
9717	EL		Work Light	ARC		AC-24V/50W	A-L81A	1
9718	XS		Y Axis Power Feed	Skeye		110V/2.5A	LK 3021F	1

UL listing electrical part list for e-mill 3VS, 3VSII, 3VK, 3VKH, 5VK, 6VK & 6VK

PART #	ITEM NAME	ACER	PARTS NAME	UL Model:	MAKER	PWR Electronic Company	PARTS CATALOG NUMBER	QTY
9503-2	R.P.M METER		Digital R.P.M Meter	3VS, 3VSII, 3VK, 3VKH, 5VK, 6VK	PWR		PWRMMX-1-A13A	1
9500	E-STOP		Emergency Stop		Allen Bradley		S04509-RWA800FPMT34	1
9500	SB3		Emergency Stop		Allen Bradley		S04509-RWA800FPMT35	1
9505-1	SB4		LIMIT Switch		Azbil		LCB1-501 10A 250VA	1
9555	S1		HI/LOW GEAR SW		OMRON		SHL-Q2255 AC-15 2A 125V	1
9501	SB1		Switch Forward		Allen Bradley		S04509-RWA800FPMT32	1
9501	SB2		Switch Reverse		Allen Bradley		S04509-RWA800FPMT32	1
9510-2	FAN		Cooling Fan		GULF		GA1123XBL AC110/120V 18/19W	1
9513	CR1		Relay Seat		OMRON		PYF-08A-E-T OMZ	1
9514			Relay		OMRON		MY-2NJ AC24V	1
9507-10	Spindle Module		Inverter		Toshiba Electric System		VF-S15 230V	1
9507-11	Spindle Module		Inverter		Toshiba Electric System		VF-S15 460V	1
9507-16	Spindle Module		Inverter		Fuji		FRN0020E2S-2GB/3PH/240V	1
9507-17	Spindle Module		Inverter		Fuji		FRN0012E2S-4GB/3PH/460V	1
9506-10	Resistor R1		Braking Resistors		Toshiba Electric System		230V ZQR450W 6.5Ω	3
9506-11	Resistor R1		Braking Resistors		Toshiba Electric System		460V ZQR450W 20Ω	3
9506-16	Resistor R1		Braking Resistors		Fuji		230V ZQR-450W 11Ω	3
9506-17	Resistor R1		Braking Resistors		Fuji		460V ZQR-450W 43.3Ω	3
9593			Terminal Block		Wago		2002-1301/3C 2.5mm	7
9594			Terminal Block		Wago		2004-1307	2
9595			Terminal Block		Wago		281-681	3
9596			Terminal End		Wago		2002-1392/3C 2.5mm	3
9597			Terminal End		Wago		2004-1391/Grey	1
9598			Terminal End		Wago		281-324	1
9502	B202 2K		Variable Resistor		JASON		2kΩ	1
9599			Screwless End				INTBR-F/ Grey	2
9562	PB1		Emergency Switch		SCHNEIDER		XB5-AS542/240V/3A/1B (RED)	1
9563	PB2		Spindle Start Switch		SCHNEIDER		XB5-AW33B1/240V/3A/1A (GED)	1
9564	PB3		Spindle Stop Switch		SCHNEIDER		XB5-AA42/240V/3A/1B (RED)	1
9565	PB4		X-Y Axis Stop Switch		SCHNEIDER		XB5-AA42/240V/3A/1B (RED)	1
9566	PB5		X-Y Axis Start Switch		SCHNEIDER		XB5-AW33B1/240V/3A/1A (GED)	1
9567	PB6		Start Switch-Up		SCHNEIDER		XB5-AA21/240V/3A/1A (BLACK)	1
9568	PB7		Start Switch-Down		SCHNEIDER		XB5-AA21/240V/3A/1A (BLACK)	1
9569	CS1		Coolant On/Off Switch		SCHNEIDER		XB5-AD21/240V/3A/1A (BLZCK)	1

ACER		UL Model:		3VS, 3VSII, 3VK, 3VKH, 5VK, 6VK	
PART #	ITEM NAME	PARTS NAME	MAKER	PARTS CATALOG NUMBER	QTY
9570-1	TR1	Transformer (For 6VK only)	LUNG GHI	LCP-TBS JY- 270/500VA 0-480V/0-110V	1
9570	TR 1	Transformer	LUNG GHI	TS01C-50VA	1
9571	QS1	Supply Disconnecting Switch	EATON	P1-25V/SVB/600V 10KA/2.5A	1
9572	FR2	Coolant Overload Relay	SCHNEIDER	LR3D03/0.25-0.4A/0.38A	1
9573	FR4	Up/Down Overload Relay	SCHNEIDER	LR3D14/7-10A/8A	1
9574	FU1	Fuse Blocks	BUSSMANN	10*38*3P/3P -600V/32A	1
9575	FU2	Fuse Blocks	BUSSMANN	10*38*1P/1P -600V/32A	1
9576	FU3	Fuse Blocks	BUSSMANN	10*38*1P/1P -600V/32A	1
9577	FU1	Fuse	BUSSMANN	FNQ/30A/3P-600A/20KA	3
9578	FU2	Fuse	BUSSMANN	ST2.5 - TWIN 3031241/1P-600A/20KA	1
9579	FU3	Fuse	BUSSMANN	ST2.5 - TWIN 3031241/1P-600A/20KA	1
9580	KM1	Spindle Magnetic Contactor	SCHNEIDER	LC1D18 B7/COIL AC-24V	1
9581	KM2	Coolant Magnetic Contactor	SCHNEIDER	LC1D09 B7/COIL AC-24V	1
9582	KM3	X-Y Axis Magnetic Contactor	SCHNEIDER	LC1D09 B7/COIL AC-24V	1
9583	KM4	Magnetic Contactor-Up	SCHNEIDER	LC1D09 B7/COIL AC-24V	1
9584	KM5	Magnetic Contactor-Down	SCHNEIDER	LC1D09 B7/COIL AC-24V	1
9592	X1	Terminal Blocks	PHOENIX	MSB2.5-MS35/600V / 20A	1
9585	HL	Indicator Light	SCHNEIDER	XB7-EV6/LED AC-24V(WHITE)	1
9586	LS2	Forward Limit Switch	MOUJEN	MJ-7103B/250V/15A	1
9587	LS3	Reverse Limit Switch	MOUJEN	TM-1308/250V/15A	1
9588	LS4	Reverse Limit Switch	MOUJEN	TM-1308/250V/15A	1
8008-1	MS1	Spindle Motor	MING-LOOUN	AC-230V/460V-3HP/2.25KW	1
5E8008-1	MS1	Spindle Motor	MING-LOOUN	AC-230V/460V-5HP/3.75KW	1
9589	MS4	Up/Down Motor	JIN SHIN	AC-230V/460V-2HP/1.492KW	1
9590	MS2	Coolant Motor	Taiwan Chang Steel Electric	MC-8180/AC230/460V	1
9591	POWER FEED	Y Axis Power Feed	ALIGN	AC-110V/90W	2
9592	EL	Work Light	GOLDEN	G-L80/AC-24V/70W	1
9001-1	LUB 110V	Lubrication Pump	CHEN-YING	CESMA-2L 110V/0.1A/4W	1

F. Amendment of UL Parts List (File No: TR14101501; Date: 4/11/19)

Original Components List					
ACER		UL Model: 3VS, 3VSII, 3VK, 3VKH, 5VK, 6VK			
PART #	ITEM NAME	PARTS NAME	MAKER	PARTS CATALOG NUMBER	QTY
9505-1	SB4	Limit Switch	Azbil	LCB1-501 10A 250VA	1
9507-10	SPINDLE MODULE	Inverter	Toshiba	VF-S15 230V	1
9507-11	SPINDLE MODULE	Inverter	Toshiba	VF-S15 460V	1
9506-10	Resistor 1	Braking Resistors		230VZQR450W 6.5Ω	3
9506-11	Resistor 1	Braking Resistors		460V ZQR450W 20Ω	3
9514		Relay	OMRON	MY-2NJ AV24V	1
9570	TR 1	Transformer	LUNG GHI	TS01C-50VA	1

Replacement Components List					
9505-2	SB4	Limit Switch	OMRON	D4E-1A2ON	1
9507-16	SPINDLE MODULE	Inverter	Fuji	FRN0020E2S-2GB 230V	1
9507-17	SPINDLE MODULE	Inverter	Fuji	FRN0020E2S-4GB 460V	1
9506-16	Resistor 1	Braking Resistors		230V ZQR450W 11Ω	3
9506-17	Resistor 1	Braking Resistors		460V ZQR450W 43.3Ω	3
9514-1		Relay	OMRON	MY2N-GS AC24V	1
9570-2	TR 1	Transformer	Shin Hsing	SHAT-55C-H 55VA1ΦH	1

PARTS NUMBER IN CIRCUIT DIAGRAM	PARTS NAME	PARTS CATALOG NUMBER	MAKER	QTY	UL No.	UL FILE
SB4	Limit Switch	D4E-1A2ON	OMRON	1	E76675	
V1	FRN0020E2S-2GB 230V/3P/3.7KW	FRN0020E2S-2GB	Fuji	1	E132902	
V1	FRN0020E2S-4GB 460V/3P/3.7KW	FRN0020E2S-4GB	Fuji	1	E132902	
R1	Braking Resistors	ZQR450W 11Ω		3		
R1	Braking Resistors	ZQR450W 43.3Ω		3		
CR1	Relay	MY2N-GS AC24V	OMRON	1	E41515	
TR 1	Single Phase Transformer	SHAT-55C-H 55VA1ΦH	Shin Hsing	1	E363386	

4-7 Alignment of Head:

In case of precision work where it is necessary to have head perfectly square with the table, please use method described below. To set head square to table, see figure 13 for 3VS, 3VK, and 3VKH & figure 14 for 5VK and 6VK.

This must be done with Ram Adapter on Ram by adjusting Ram Adapter through vertical adjusting worm shaft. Loosen four locknuts, but leave some drag for fine adjustment. To square head to table in the longitudinal axis, mount indicator as shown in Figure.

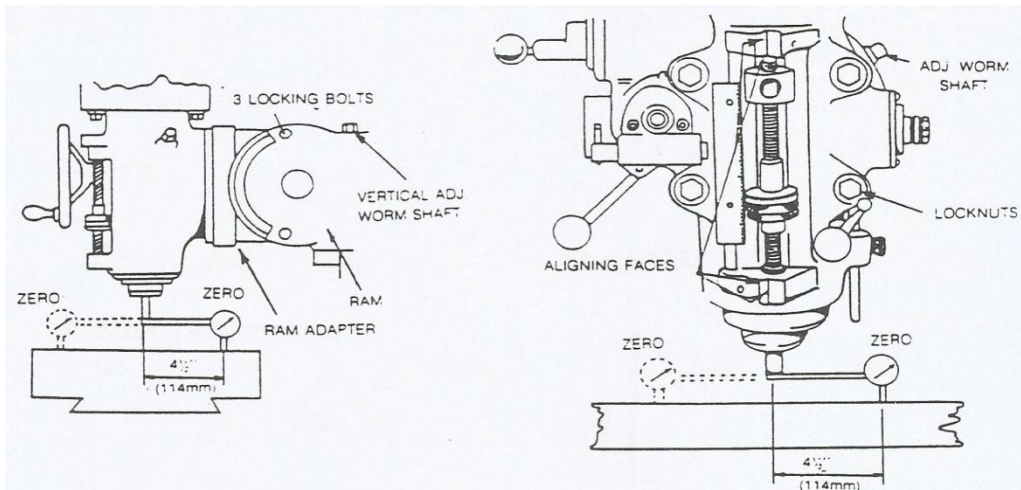

Figure 13. Head alignment Y & X axes

NOTE
WHEN SETTING HEAD ALIGNMENT, AS IN FIGURES,
IT SHOULD BE NOTED THAT THE TABLE IS
DESIGNED TO BE SLIGHTLY HIGHER IN FRONT,
USUALLY ABOUT .0005"

For model 5VK & 6VK, to set head square with table, loosen four locknuts, mount indicator as show in figure 14.

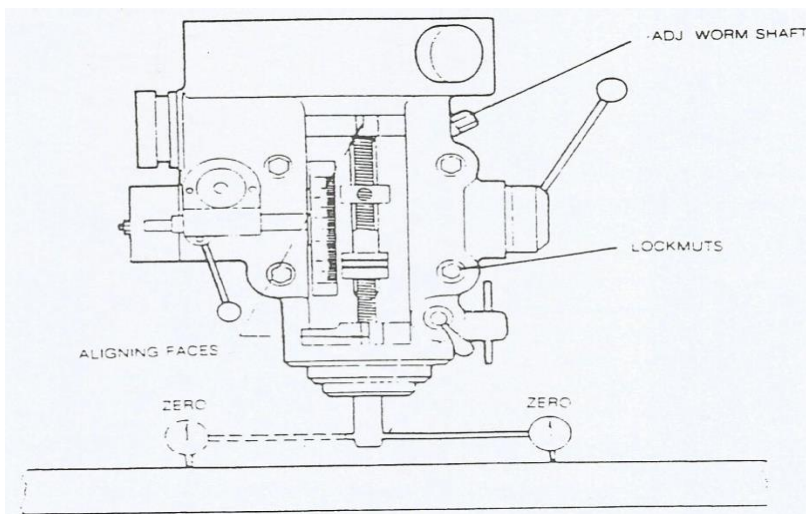

Figure 14. Head alignment for 5VK & 6VK

5. LUBRICATION

Do not operate machine until properly lubricated:

- (A) Way surfaces and lead screws (Sunoco waylube #80 or equivalent); one pump daily.
- (B) Milling head and spindle bearings (S.A.E. 10 or 10W light oil); weekly.
- (C) Elevation screw (Shell Carnea Oil 41); twice weekly.
- (D) Motors are greased for life of bearings.

5-1 Lubrication System of e-mill 3VS and 3VSII

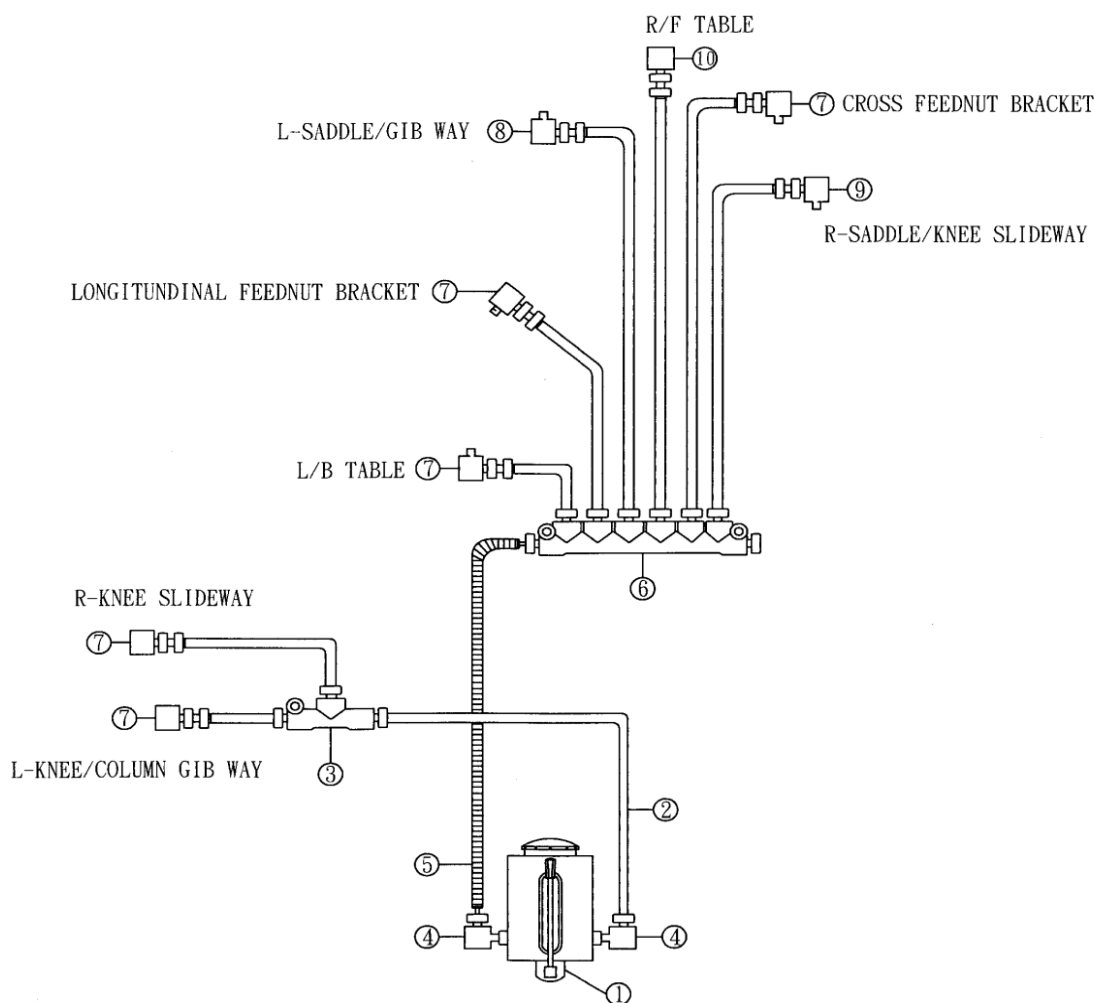

Item#	Part#	Description	Item#	Part#	Description
1	9001	Hand Oiler	2	9002	Aluminum Pipe (4mm)
3	9004	A4 Distributing Joint	4	9022	Elbow Joint
5	9006	Flexible Oil Tube (410mm)	6	9024	A8 Distributing Joint
7	9005	Oil Check Valve-ST1	8	9008	Oil Check Valve-ST2
9	9007	Oil Check Valve-ST4	10	9010	Oil Check Valve-ST5

5-2 Lubrication System of e-mill 3VK

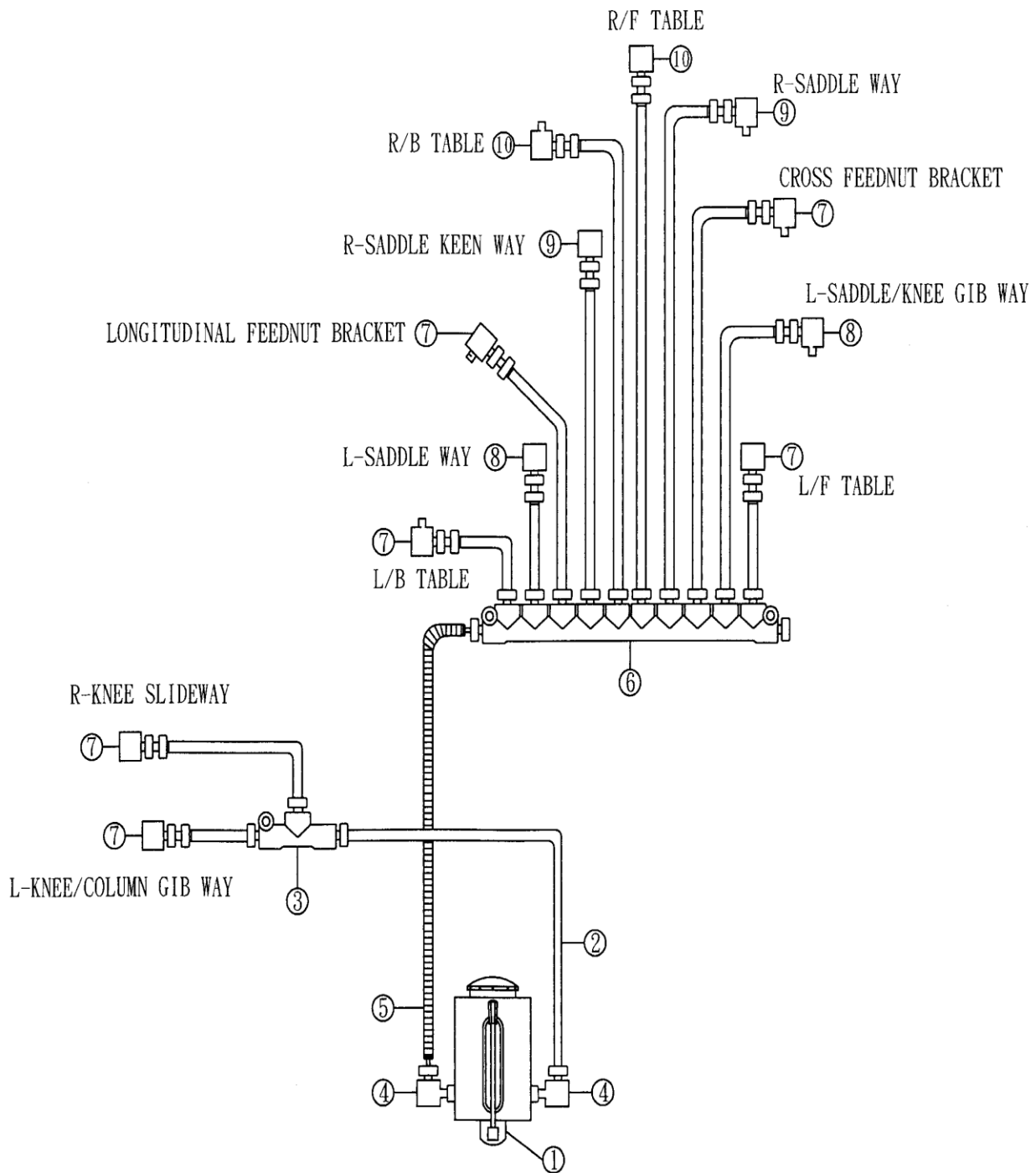

Item#	Part#	Description	Item#	Part#	Description
1	9001	Hand Oiler	2	9002	Aluminum Pipe (4mm)
3	9004	A4 Distributing Joint	4	9022	Elbow Joint
5	9060	Flexible Oil Tube (500mm)	6	9009	A12 Distributing Joint
7	9005	Oil Check Valve-ST1	8	9008	Oil Check Valve-ST2
9	9007	Oil Check Valve-ST4	10	9010	Oil Check Valve-ST5

5-3 Lubrication System of e-mill 3VKH & 5VK

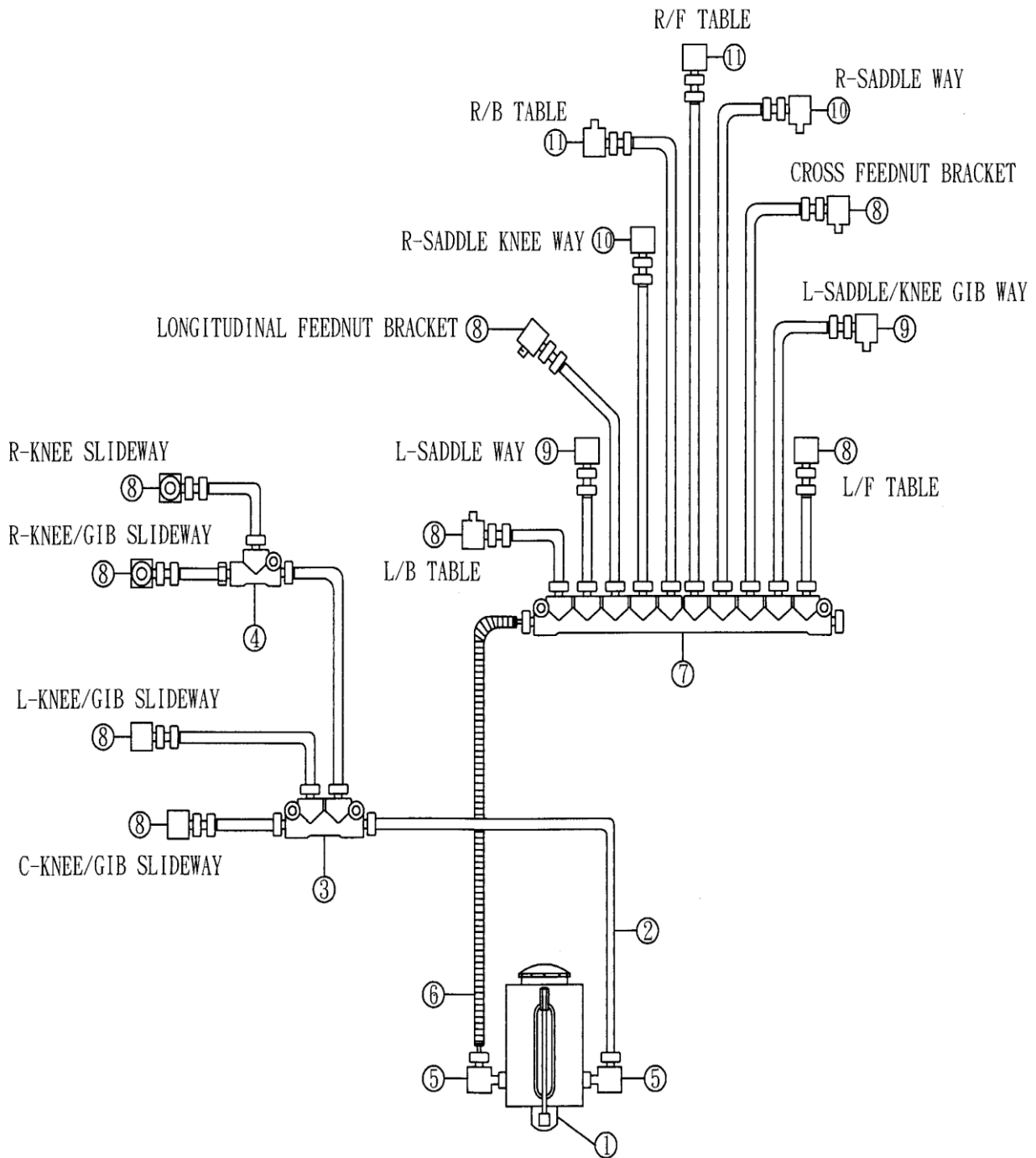

Item#	Part#	Description	Item#	Part#	Description
1	9001	Hand Oiler	2	9001	Aluminum Pipe (4mm)
3	9021	A4 Distributing Joint	4	9004	A3 Distributing Joint
5	9022	Elbow Joint	6	9060	Flexible Oil Tube (500mm)
7	9009	A12 Distributing Joint	8	9005	Oil Check Valve-ST1
9	9008	Oil Check Valve-ST2	10	9007	Oil Check Valve-ST4
11	9010	Oil Check Valve-ST5			

5-4 Lubrication System of e-mill 6VK

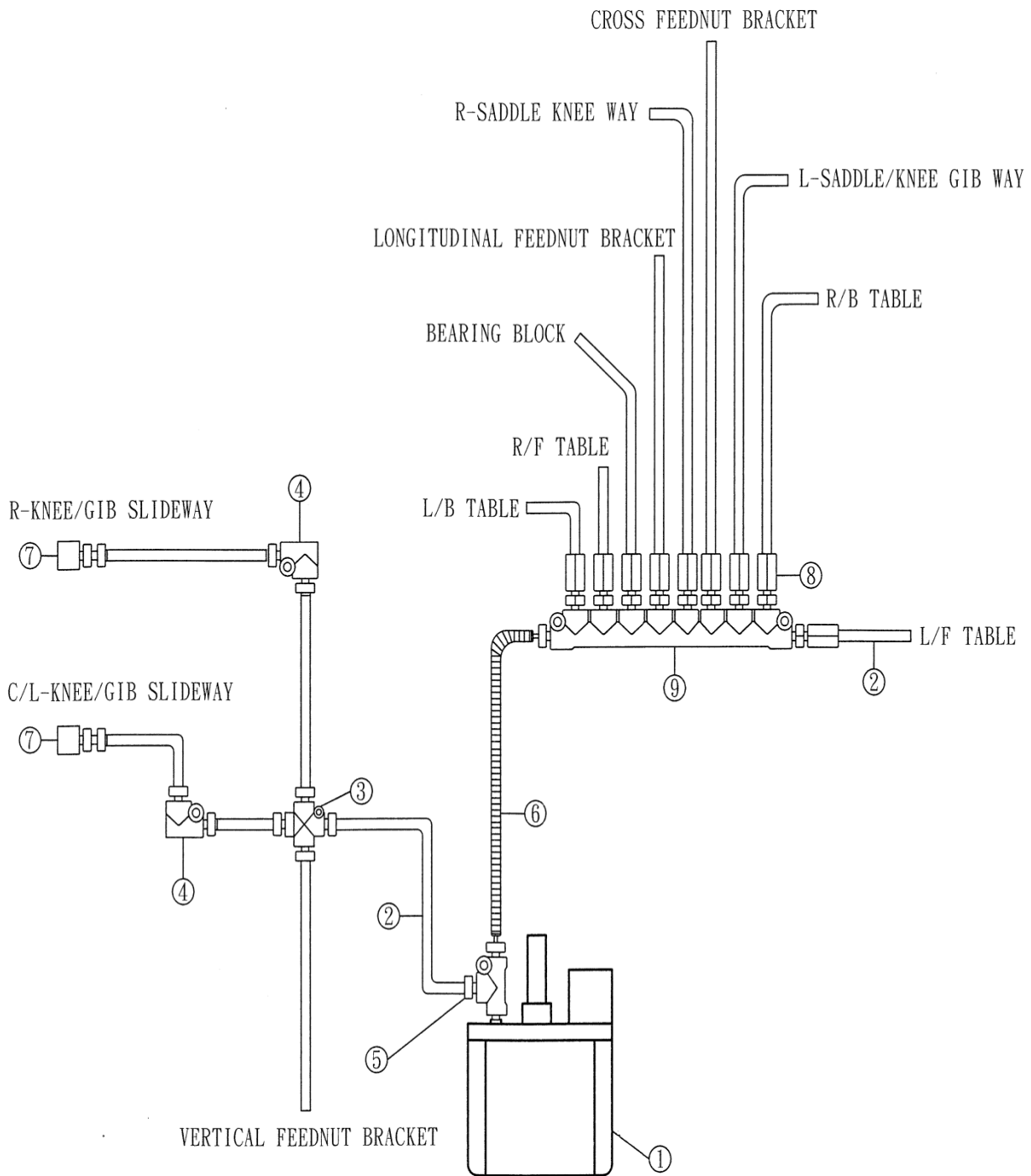

Item#	Part#	Description	Item#	Part#	Description
1	9054	Auto Lubrication Pump	2	9001	Aluminum Pipe (4mm)
3	9055	PJD4- Distributing Joint	4	9058	PT4 Distributing Joint
5	9056	SS5 Distributing Joint	6	9059	Flexible Oil Tube
7	9057	Oil Check Valve-PV4	8	9057	Oil Check Valve-PV4
9	9053	A10 Distributing Joint			

5-5. Lubrication Schedule for All e-mills

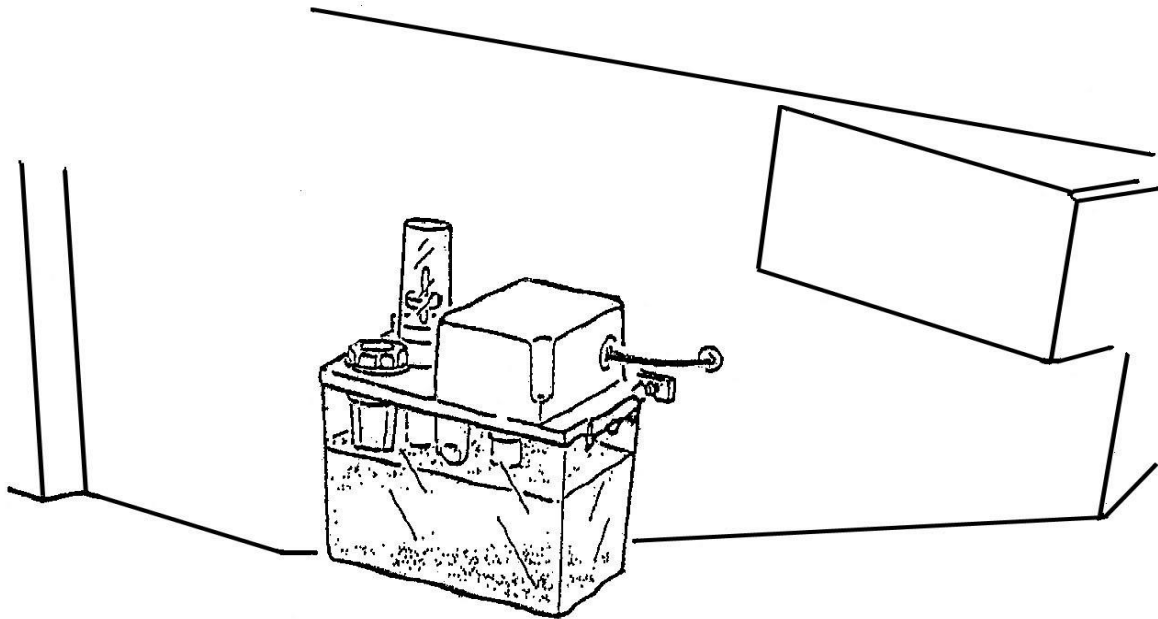

LUBRICATING AREA	LUBRICANT	FREQUENCY	QUANTITY
X & Y LEAD SCREWS	SHELL CORNEA OIL 41	CENTRALIZED LUBRICATION PUMP DAILY CHECK LEVEL WEEKLY	FEW PUMPS DAILY UNTIL VISUALLY SEEING OIL
	MOBIL VACTRA #2		
	SONOCO GARGOYLE VACTRA NO. 2		
SADDLE TABLE WAYS	"SUNOCO" WAY LUBE #80 MOBIL VACTRA #2		
SADDLE WAYS			
KNEE COLUMN WAYS			
6VK ONLY ELEVATING SCREW	SHELL CORNEA OIL 41	TWICE A WEEK	OIL GUN FIVE SHOTS
	MOBIL VACTRA #2		
	SOCONO GARGOYLE VACTRA NO. 2		
OIL CUPS ON HEAD HOUSING	ISO VG#10	DAILY	FEW DROPS
GREASE NIPPLE	SILICONE BASE GREASE	ONCE A WEEK	FEW PUMPS

5-6. MSDS for Lubricant in Lubrication Pump

Material Safety Data Sheet

No : L102 CPC Machine Way Lubricant 32 、 68 、 150 、 220

Ver 3.0

I. CHEMICAL PRODUCT AND COMPANY IDENTIFICATION

Product Name:CPC Machine Way Lubricant 32 、 68 、 150 、 220

Product Code:LA81032(32) 、 LA81068(68) 、 LA81150(150) 、 LA81220(220)

Manufacturer Name: Lubricants Business Division, CPC Corporation, Taiwan

Address:

6F, 15, Cheng-Kung 2nd RD, Chen-Zerng District, Kaohsiung, 806,Taiwan, R.O.C.

Telephone Number: 886-7-5361510

Emergency Telephone Number: 886-5-2224171 Ext. 7103 or 6666

Fax Number: 886-5-2232062

II. HAZARDS IDENTIFICATION

NFPA Ratings (Scale 0-4): NFPA Fire=1

The Most Important Hazardous Effects:

1. Adverse Human Health Effects:

(For Long Term Exposure)

1. Eye Contact: irritation.
2. Skin Contact : skin disorders.
3. Inhalation: If heated this substance ,over-inhalation may cause headache, dizziness, nausea ,vomiting, coughing, pain in the nose, throat and chest.
4. Ingestion: no information is available .

2. Environmental Effects: no information is available.

3. Physical and Chemical Hazards: Mist or vapors can produce at elevated temperatures.

4. Specific Hazards: no information on significant adverse effects.

Main Symptoms:

1. Eye Contact : irritation.
2. Skin Contact : skin disorders.
3. Inhalation : If heated this substance ,over-inhalation may cause headache, dizziness, nausea ,vomiting, coughing, pain in the nose, throat and chest.
4. Ingestion :aspiration hazard, digestive disorders.

III. COMPOSITION, INFORMATION ON INGREDIENT

1. Product Identification:

Chemical Family: Petroleum Hydrocarbons

Chemical Formula: Mixture

Trade Name/Synonym: Not assigned

2. Component:

Ingredients CAS Number % by vol.

Machine Way Lubricant Additive Not assigned 1~10

Heavy Paraffinic Distillate 64742-54-7 < 100

Bright Stock 64742-54-7

IV. FIRST AID MEASURE

Emergency Procedures:

1. Inhalation :

Remove personnel from exposure area to fresh air immediately. If breathing is difficult, give oxygen. If breathing ceases, use an oxygen rescuer or similar device to perform artificial respiration. Get medical attention immediately.

2. Skin Contact :

Remove contaminated clothing, jewelry and shoes immediately. Wash with soap or mild detergent and large amounts of water until no evidence of chemical remains (at least 15~20 minutes). If irritation or adverse symptoms develop, seek medical attention.

3. Eye Contact :

Flush eyes immediately with running water for at least fifteen minutes, occasionally lifting upper and lower lids, until no evidence of chemical remains. Get medical attention immediately.

4. Digestion :

If swallowed, do not induce vomiting. If conscious, give 1~2 water to drink. If vomiting occurs, keep head lower than hips to help prevent aspiration. Get medical attention immediately.

Protection of First-aiders: no information is available.

Notes to Physician: no information is available.

V. FIRE FIGHTING MEASURES

Suitable Extinguishing Media: regular dry chemical, carbon dioxide, water, regular Foam.

Large fires: Use regular foam or flood with fine water spray.

Specific Hazards: combustion conditions, oxides of the following elements will be formed: carbon dioxide, water, sulfur, nitric oxide. Incomplete burning can produce carbon monoxide and other harmful products.

Special Fire Fighting Procedures:

1. Firefighters should wear proper protective equipment stay upwind.
 2. Move container from fire area and shut off source if it can be done without risk.
 3. Cool containers with water spray until well after the fire is out.
 4. Do not scatter spilled material with high-pressure water streams.
 5. Keep unnecessary people away, isolate hazard area and deny entry.
 6. Avoid inhalation of material or combustion by-products.
-

VI. ACCIDENTAL RELEASE MEASURES

Personal Precautions:

1. Avoid heat, flames, sparks and other sources of ignition.
 2. Stop leak if possible without personal risk.
 3. Reduce vapors with water spray.
-

Environmental Precautions:

1. Eliminate all open flame in vicinity of spill or released vapor.
 2. Stop the source of the leak or release.
 3. Clean up releases as soon as possible.
 4. Contain liquid to prevent further contamination of soil, surface water or groundwater.
-

Methods for Cleaning Up:

1. Clean up small spills using sand or other non-combustible material.
 2. Collect spilled material in appropriate container for disposal.
 3. Where feasible and appropriate, remove contaminated soil.
 4. Follow prescribed procedures for reporting and responding to larger releases.
-

VII. HANDLING AND STORAGE

Handling:

1. Wear protective equipment, if exposure conditions warrant.
 2. Wash thoroughly after handling.
 3. Use with adequate ventilation.
 4. Handle in accordance with all current regulations and standards.
-

Storage:

1. Keep away from heat, sparks and flames.
 2. Store in well-ventilated area.
 3. Store in a tightly closed container.
 4. Store in a cool, dry place.
 5. Bond and ground during transfer.
 6. Keep separated from incompatible substances.
 7. Storage in accordance with all current regulations and standards.
-

VIII. EXPOSURE CONTROLS AND PERSONAL PROTECTION

Engineering Control:

Provide local exhaust ventilation system. Ensure compliance with applicable exposure limits.

Control Parameter:

HAZARDOUS MATERIAL	TWA	STEL	CEILING
Mineral Oil Mist	ACGIH: 5 mg/m ³ NIOSH: 5 mg/m ³ OSHA : 5 mg/m ³	NIOSH : 10mg/m ³ UK OES : 10mg/m ³	--

Personal Protection Equipment:

1. Respiratory Protection:
Not generally required unless needed to prevent respiratory irritation. In case of spill or leak resulting in unknown concentration, use NIOSH approved supplied air respirator.
2. Hand Protection:
Wear appropriate chemical resistant gloves.
3. Eye Protection:
Wear splash resistant safety goggles or face shield. Provide an emergency eye wash fountain and quick drench shower in the immediate work area.
4. Skin and Body Protection:
Wear appropriate chemical resistant clothing. Remove any chemical soaked clothing immediately.

IX. PHYSICAL AND CHEMICAL PROPERTIES

Physical State: liquid	Form: brown liquid
Color: deep brown	Odor: no special odor
PH: Not available	Boiling Range: No data
Decomposition Temperature: No data	Flash Point: : 226 °C (438°F)(32) 228 °C (438°F)(68) 232 °C (450°F)(150) 250 °C (482°F)(220) Test Method: Open Cup
Autoignition Temperature: No data	Flammable Limits: Not available
Vapor Pressure: Not available	Vapor Density: Not available
Specific Gravity: 0.872g/cm ³ @ 60°F(32)	Solubility: insoluble in water

0.881g/cm³ @ 60°F(68)
0.888g/cm³ @ 60°F(150)
0.894g/cm³ @ 60°F(220)

X. STABILITY AND REACTIVITY

Stability: Stable at normal temperatures and pressure.

Possible Hazardous Reactions: Will not polymerize.

Conditions to Avoid:

Avoid heat, flames, spark and other sources of ignition. Avoid contact with incompatible material.

Materials to Avoid: acid, strong oxidizing agents.

Hazardous Decomposition Products:

oxides of carbon, various hydrocarbons and sulfide formed when burned.

XI. TOXICOLOGICAL INFORMATION

Acute Toxicity:

1. **Inhalation:**

Paraffinic distillate: Mists or sprays of insoluble oils are not harmful to the respiratory tract, although worker discomfort may occur at oil mist level of 5 mg/m³.

Machine Way Lubricant additive: inhalation of oil mist or vapors may cause respiration irritation.

2. **Skin Contact:**

Paraffinic distillate: May cause hair follicles, comedones, perifollicular papules and pustules.

Machine Way Lubricant additive: irritate to skin.

3. **Eye Contact:**

Paraffinic distillate: Found to be moderately irritating to eyes.

Machine Way Lubricant additive: irritate to eyes.

4. **Ingestion:**

Paraffinic distillate: may cause gastrointestinal disturbance such as diarrhea.

Machine Way Lubricant additive: No data available.

Local Effect: No data available.

Sensitization: No data available.

Chronic Toxicity:

1. Inhalation:
Repeated or prolonged contact with oils may cause fibrotic nodules, lipoid pneumonia, and lipid granuloma.
2. Skin Contact:
Repeated or prolonged contact may cause defatting of the skin which may result in dermatitis and effect as detailed in acute exposure.
3. Eye Contact: Repeated or prolonged contact with irritants may cause conjunctivitis.
4. Ingestion: No data available.

Specific Effects: No data available.

XII. ECOLOGICAL INFORMATION

Environmental Mobility: No data available.

XIII. DISPOSAL CONSIDERATIONS

Subject to disposal regulations:

Dispose in accordance with all applicable regulations.

XIV. TRANSPORT INFORMATION

No classification assigned.

XV. REGULATORY INFORMATION

Suitable Regulations:

1. U.S. Regulations:

TSCA Inventory Status: Y

SARA Hazard Categories, SARA Sections 311/312(40 CFR 370.21):

Acute: N

Chronic: N

Fire: N

Reactive: N

OSHA Process Safety(29 CFR 1910.119): N

2. State Regulations:

California Proposition 65: N

3. European Regulations:
EC Number: Not assigned

XVI. OTHER INFORMATION

Reference Literatures	1.OHS 15037
	2. OHS 50243
<hr/>	
Lubricants Business Division, CPC Corporation, Taiwan	
Made By	Title : Project Manager Name : Fong-Wu Chen
Creation Date	March. 28, 2011

CPC Corporation, Taiwan (CPC) believes that the information contained herein (including data and statements) is accurate as of the date hereof.
NO ANY WARRANTY, EXPRESS OR IMPLIED, IS MADE AS CONCERNS THE INFORMATION HEREIN PROVIDED.

The information provided herein relates only to the specific product designated and may not be valid not be valid where such product is used in combination with any other materials or in any process. Further, since the conditions and methods of use of the product and information referred to herein are beyond the control of CPC.

CPC expressly disclaims any and all liability as to any results obtained or arising from any use of product or such information.

6. OPERATION

Note: Safety operation rules review

1. **SECURE WORK.** Use chuck to hold work piece when it is practical. It is safer than using your hand and this way it frees operator's hands to operate the lathe.
2. **DO NOT OVERREACH.** Keep proper footing and balance at all times.
3. **MAINTAIN CUTTING TOOLS WITH CARE.** Keep tools sharp and clean for the best and safest performance. Follow instructions for lubricating and changing accessories.
4. **DISCONNECT POWER** before servicing, when changing accessories such as cutting tools.
5. **REDUCE THE RISK OF UNINTENTIONAL STARTING.** Make sure **EMERGENCY** switch is at off-position before connecting power.
6. **USE RECOMMENDED ACCESSORIES.** Consult the owner's manual for recommended accessories. The usage of improper accessories may cause risk or injury to the operators.
7. **NEVER STAND ON TOOLS.** Serious injury could occur, if the operator is tripped by the tools, or if the cutting tool is unintentionally contacted.
8. **CHECK FOR DAMAGE PARTS.** Before further using a tool, a guard or other parts that appears damaged, operator should carefully checked the item to determine that it will operate properly and perform its intended function. Please check for alignment and binding of moving parts, breakage of the parts, mounting, and any other conditions that may affect its operation. A guard or other part that is damaged should be properly repaired or replaced.
9. **NEVER LEAVE LATHE RUNNING UNATTENDED, PLEASE TURN ITS POWER OFF.** Don't leave the lathe until it comes to a complete stop.
10. **ALWAYS USE SAFETY GLASSES.** Common eyeglasses only have impact resistant lenses, they are NOT safety glasses.
11. **KEEP GUARDS IN PLACE** and in working order.
12. **REMOVE ADJUSTING KEYS AND WRENCHES.** Form a habit of checking to see that keys and adjusting wrenches are removed from lathe before turning it on.
13. **KEEP WORK ARE A CLEAN.** Cluttered areas will invite accidents.
14. **DON'T USE TOOLS IN DANGEROUS ENVIRONMENT.** Don't use power tools in damp or wet location, or expose them to rain. Keep working area well lighted.
15. **KEEP CHILDREN AWAY.** All visitors should be kept at a safe distance from work area.
16. **MAKE WORKSHOP CHILD PROOF** with padlocks, master switches, or by removing starter keys.
17. **DO NOT FORCELY USING CUTTING TOOLS.** Don't force a tool or attachment to do a job for which it was not designed for.
18. **USE THE RIGHT CUTTING TOOL.** It will do the job better and safer at the rate for which it was designed for.
19. **WEAR PROPER APPAREL.** No loose clothing, gloves, neckties, rings, bracelets, or other jewelry to have chance to get caught in moving parts of the lathe. Non-slip footwear is recommended, and wears protective hair cover to contain long hair.

20. Never use the high speed range continuously over one hour.
21. KEEP CUTTING TOOLS TIGHT during operation.

6-1 Nomenclature

e-mill 3VS, 3VSII, 3VK & 3VKH

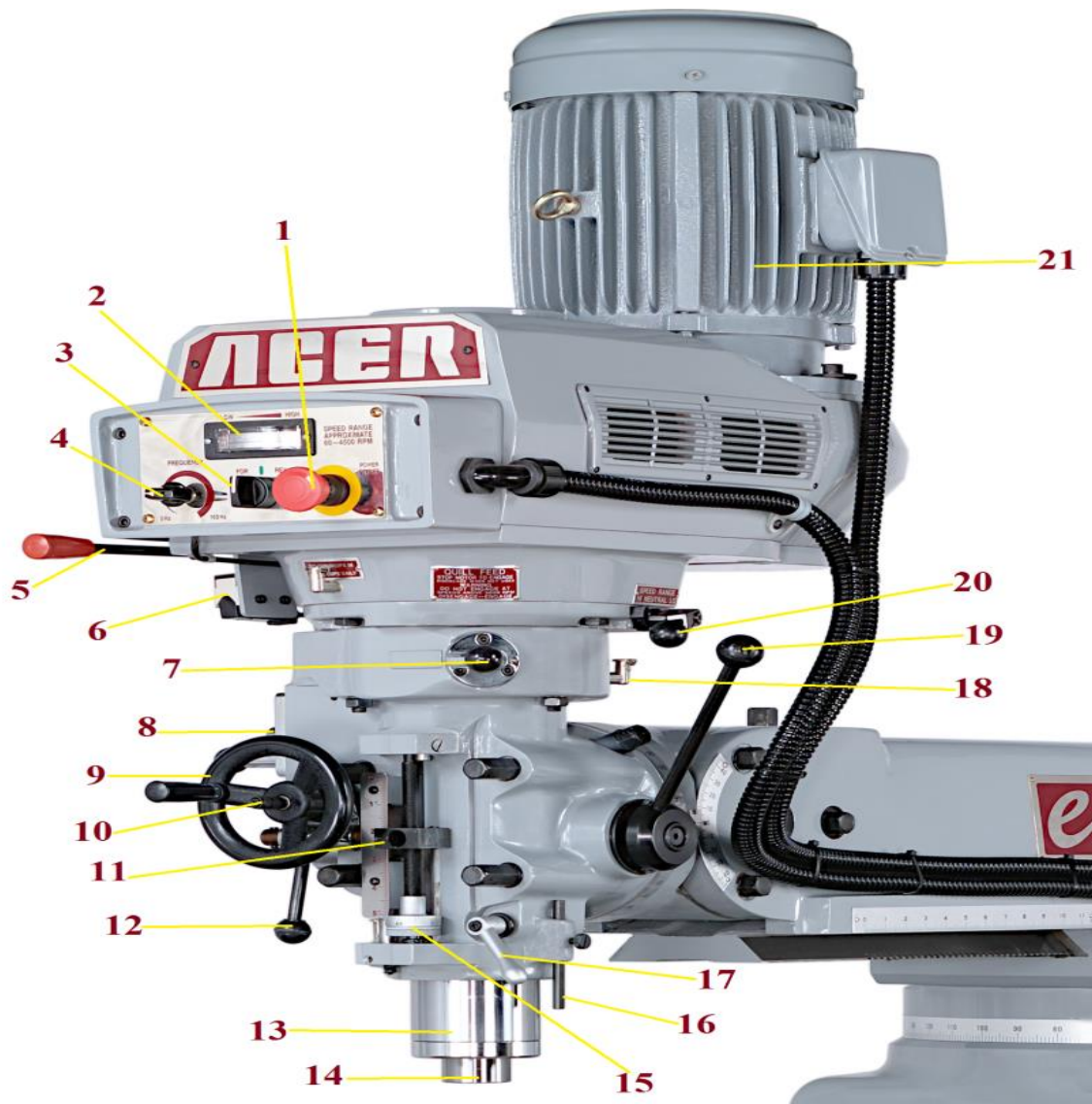

Item #	Description	Item #	Description
1	EMERGENCY STOP	11	QUILL STOP KNOB
2	RPM DIGITAL COUNTER	12	FEED CONTROL LEVER
3	FOR/REV SWITCH	13	QUILL
4	VARIABLE SPEED RESISTOR	14	SPINDLE
5	SPINDLE BRAKE HANDLE	15	MICROMETER ADJUSTING NUT & LOCKNUT
6	SPINDLE BRAKE LIMIT SWITCH	16	INDICATOR MOUNTING ROD
7	POWER FEED TRANSMISSION ENGAGEMENT CRANK	17	QUILL LOCK HANDLE
8	QUILL FEED SELECTOR	18	OIL CUP
9	MANUAL FEED HANDWHEEL	19	QUILL FEED HANDLE
10	FEED REVERSING KNOB	20	HI-NEUTRAL-LOW LEVER
		21	SPINDLE MOTOR

e-mill 5VK & 6VK

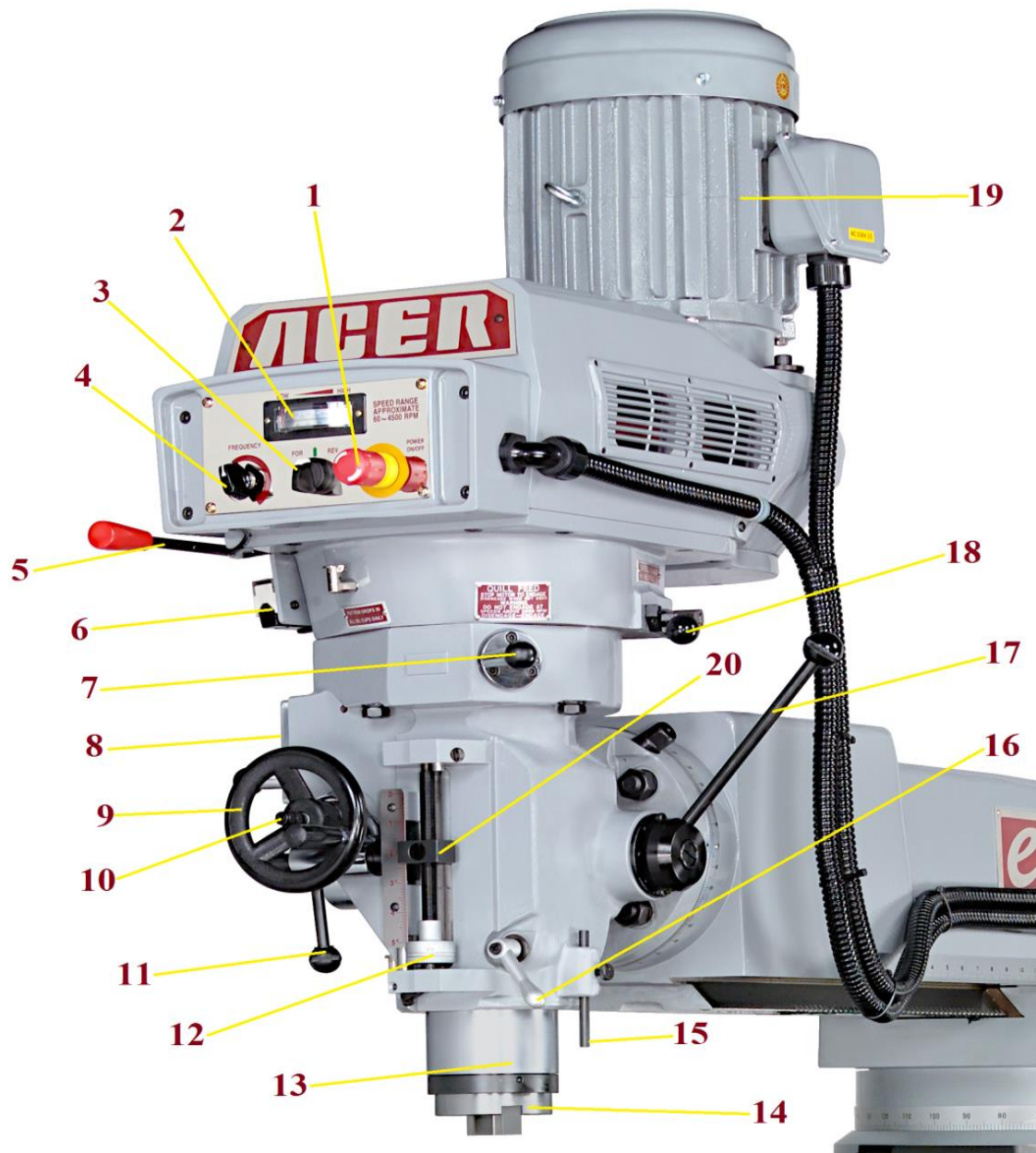

Item #	Description	Item #	Description
1	EMERGENCY STOP	11	FEED CONTROL LEVER
2	RPM DIGITAL COUNTER	12	MICROMETER ADJUSTING NUT & LOCKNUT
3	FOR/REV SWITCH	13	QUILL
4	VARIABLE SPEED RESISTOR	14	SPINDLE
5	SPINDLE BRAKE HANDLE	15	INDICATOR MOUNTING ROD
6	SPINDLE BRAKE LIMIT SWITCH	16	QUILL LOCK HANDLE
7	POWER FEED TRANSMISSION ENGAGEMENT CRANK	17	QUILL FEED HANDLE
8	QUILL FEED SELECTOR	18	HI-NEUTRAL-LOW LEVER
9	MANUAL FEED HANDWHEEL	19	SPINDLE MOTOR
10	FEED REVERSING KNOB	20	QUILL STOP KNOB

6-2 Draw Bar

DO NOT attempt to change spindle RPM unless the motor is running, expressed speeds will only be approximate. Belt wear will cause variations in speed, from the speed indicated by the digital counter.

When tightening or loosening the drawbar, it is necessary to lock the spindle. To do this, use the spindle brake (5) which is located on the left side of the belt housing. Pull it down until the spindle binds. Make sure the quill is raised all the way.

Drawbar has $7/16$ "-20 right hand thread on model 3VS, 3VSII, 3VK, 3VKH; $5/8$ "-11 right hand thread on model 5VK, 6VK, and should be tightened with normal pressure using wrench furnished with machine. To loosen collet, back off drawbar, and if collet does not open immediately, please give the top of drawbar a slight tap. The spindle has non-sticking taper and the collet should release easily.

6-3 Spindle Brake (#5)

Brake lever must be pull down to stop spindle electronically. When locking spindle, lever should be pull-down. There are no adjustments on brake, so it must be replaced when worn out.

CAUTION
BE CERTAIN THAT THE SPINDLE BRAKE IS
RELEASED BEFORE STARTING THE MOTOR. THE
MOTOR CAN BE DAMAGED IF SWITCH IS TURNED
ON WITH BRAKE IN LOCKED POSITION.

6-4 Forward-Reverse Switch (#3)

This is the motor reversing switch. When the head is in direct drive (High Range) the motor and spindle are turning the same direction. When the head is in "Back Gear" (Low Range) the spindle runs backwards unless the motor direction is reversed.

6-5 Hi-Neutral-Lo Lever (#18 on 5HP or #20 on 3HP)

This lever is used to put the head into either direct drive or back gear. Rotate the spindle by hand to facilitate meshing of clutch or gears.

Neutral can be obtained at mid-way position, and is provided to permit free spindle rotation for indicating and set-up.

After an extended period of use, the neutral position may cause noise by allowing the clutch teeth to rub each other. This can be corrected by loosening set screw (#43, page 111) and reversing the position of the detent plate (#44, page 111).

In high speed (Direct Drive), the spindle is driven by tapered clutch teeth. If the clutch is not meshed tightly, clutch rattle will be heard. This can be corrected by moving the detent plate upward as the clutch wears. This may also cause loss of neutral, requiring reversal of the detent plate.

CAUTION
DO NOT SHIFT HI-LO LEVER WHILE THE MOTOR IS
RUNNING.

6-6 Power Feed Engagement Crank(#7)

Engages power feed worm gear. When lever is in right hand hole, power feed is engaged. To disengage, pull knob out and turn crank clockwise and move to opposite position.

NOTE
Handle must be moved in clockwise direction to engage or disengage power feed. If handle is moved counter-clockwise no damage will be done, but nothing will happen.

CAUTION
POWER FEED GEAR MAY BE ENGAGED WHILE
SPINDLE IS TURNING. HOWEVER, IT SHOULD BE
ENGAGED SLOWLY TO AVOID DAMAGE TO THE
WORM GEAR. THE GEAR MAY BE DISENGAGED AT
ANY TIME. DO NOT USE POWER FEED AT SPEEDS
ABOVE 3000 RPM.

IMPORTANT
IT IS RECOMMENDED THAT THE POWER FEED
WORM GEAR BE DISENGAGED WHENEVER THE
POWER FEED IS NOT REQUIRED. THIS WILL AVOID
UNNECESSARY WEAR ON PWER FEED WORM GEAR.

6-7 Quill Feed Selector (#8)

This crank is used to select the feed rate. It is shifted by pulling knob out and turning from one position to another. Feed rates are stamped on cover below each hole. Feed is more readily engaged with spindle running.

6-8 Feed Reverse Knob (#10)

Position of this knob depends upon direction of spindle rotation. If boring with right hand cutting tools, pull feed handle towards operator until clutch becomes engaged.

Neutral position is between forward and reverse position. It is recommended that the handle be left in neutral position when not in use.

6-9 Manual Feed Handwheel (#9)

Feed reversing knob should be in neutral position and feed control lever engaged. Clockwise rotation of handwheel moves quill down. Manual Feed Handwheel and

quill feed handwheel may be disengaged by moving them outward approximately $\frac{1}{8}$ ".

NOTE

The feed control lever must be engaged in order to use manual feed controls. The Quill Feed handle and Manual Feed Handwheel may be taken off when not in use.

6-10 Feed Control Lever (#11 on 5HP & #12 on 3HP)

When this lever is moved left it engages over-load clutch on pinion shaft. Clutch will remain engaged until either quill stop comes in contact with micrometer adjusting nut (forcing feed control lever to disengage automatically), or lever is released manually by moving it to the left.

NOTE

The Feed Control Lever's factory default is to disengage automatically when the quill stop pushes against the micrometer adjusting nut or throw adjustment. It may easily be brought back by regulating the socket set screw located at the bottom of the tripping rod.

CAUTION

WHEN ADJUSTING THE SOCKET SET SCREW, CHECK AUTOMATIC DISENGAGEMENT IN BOTH DIRECTIONS: THAT IS WITH THE QUILL-STOP NUT AGAINST THE FEED TRIP LEVER FOR DOWN POSITION, AND AGAINST REVERSE TRIP BALL LEVER FOR THE UP POSITION.

6-11 Quill Feed Handle (#17 on 5HP & #19 on 3HP)

May be removed by simply pulling handle off! It is recommended that handle be disengaged when using power feed.

6-12 Quill Stop Knob (#20 on 5HP & #11 on 3HP)

It is used to disengage power feed in either direction as well as acting as a depth stop when working to a given depth.

6-13 Micrometer Adjusting Nut (#12 on 5HP & #15 on 3HP)

This nut is used for setting depth. Each graduation on nut indicates 0.001" (0.02mm) and reads directly from the scale mounted along its side. Depths may be adjusted by setting micrometer nut in conjunction with quill stop.

6-14 Quill Lock (#16 on 5HP & #17 on 3HP):

This is a friction lock to be used when the quill is in a stationary position, such as for milling. It is recommended this lock be used whenever quill movement is not desired.

6-15 Ram Position

- A. Ram can be moved by loosening three ram lock studs on turret and moving to desired position.

CAUTION
CARE SHOULD BE TAKEN TO LOCK RAM SECURELY
AFTER SETTING.

NOTE
It is recommended that on heavy milling work, head should be kept as close to column as possible, where maximum rigidity is obtained.

B. Swiveling Turret and Moving Ram on 6VK

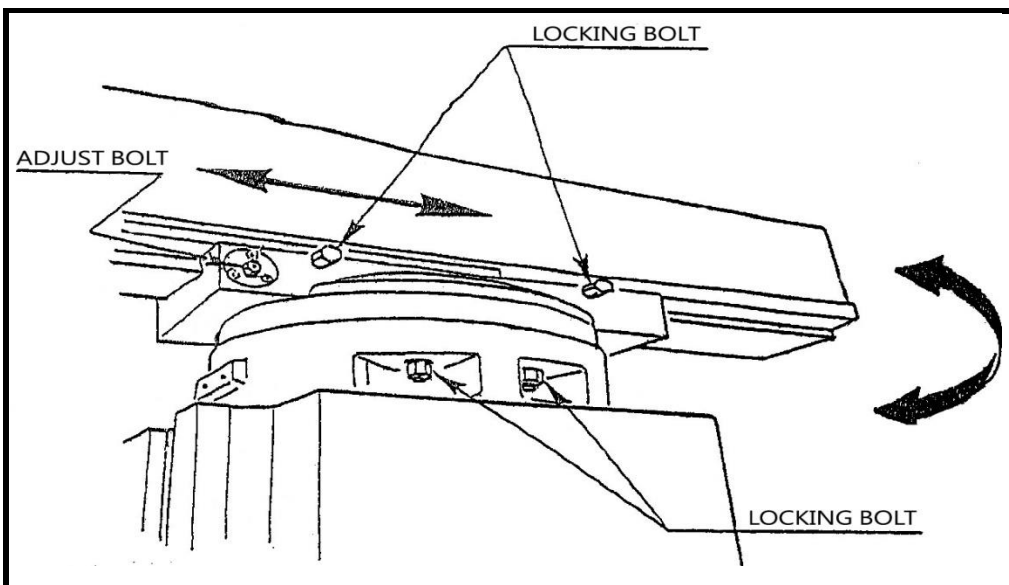

SWIVELING TURRET:

1. USE SPANNER WRENCH TO UNLOCK THE FOUR LOCKING BOLTS.
2. ROTATE TO THE REQUIRED ANGLE SETTING.
3. LOCK THE FOUR BOLTS.

MOVING RAM:

1. USE SPANNER WRENCH TO UNLOCK THE TWO BOLTS.
2. TURN THE ADJUSTMENT BOLT TO MOVE THE RAM TO THE REQUIRED POSITION.
3. LOCK AND TIGHTEN THE REAR BOLT FIRST, THEN THE FRONT ONE.

6-16 Clamping Table, Saddle and Knee:

When milling with longitudinal table feed only it is advisable to clamp the knee to the column and the saddle to the knee to add rigidity to these members and provide

for heavier cuts with a minimum of vibration. The saddle locking lever is located on the left-hand side of the saddle.

Excessive pressure can cause slight table bind. Use moderate clamping pressure, as this will hold saddle sufficiently.

The table clamp levers are located on the front of saddle and should always be clamped when longitudinal movement is not required.

For Model e-mill 3VS, 3VSII & 3VK

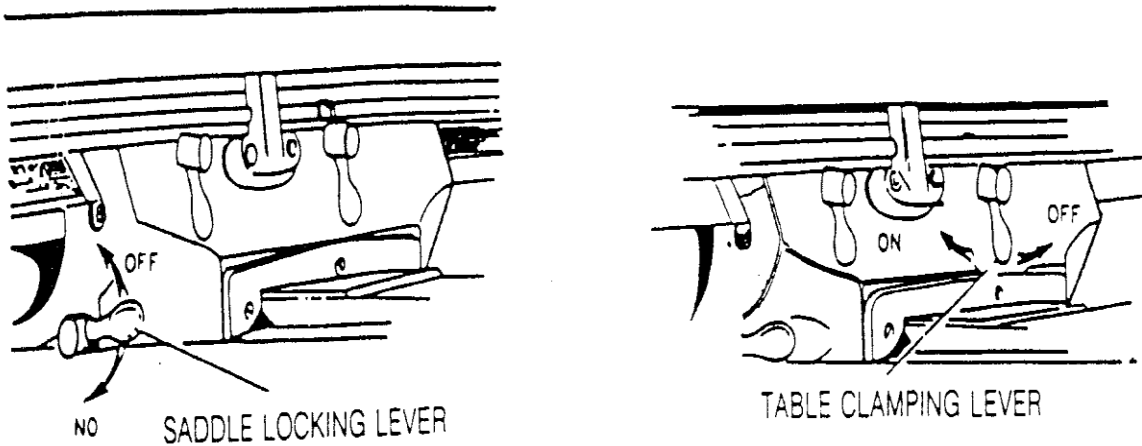

Figure 15. Table & saddle clamping lever

For model e-mill 3VKH, 5VK & 6VK

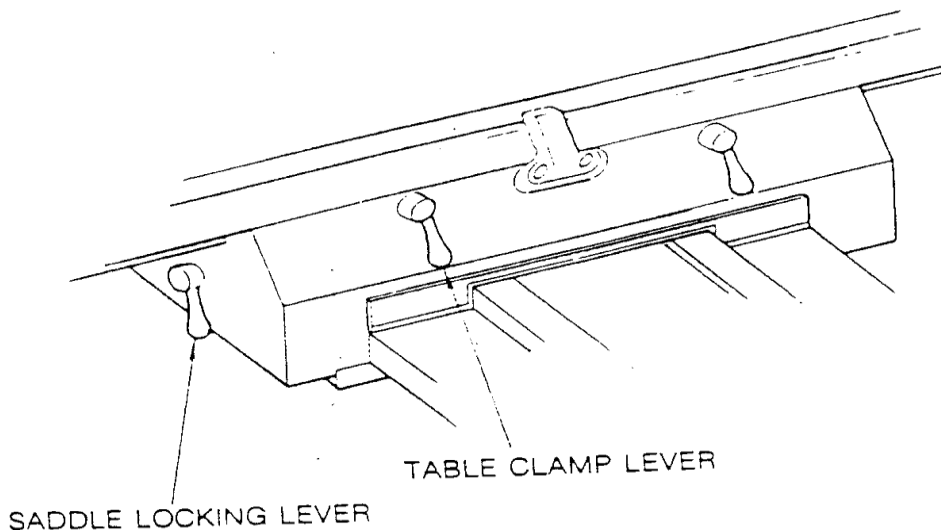
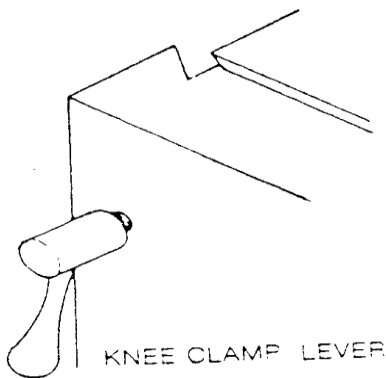

Figure 16. Table & saddle clamping lever

The knee clamping lever is at the left side of the knee and should be drawn upward to clamp the knee. This is only a tension brake and will not lock the knee completely. Leave clamped at all times unless using knee in operation.

Note: The two clamps on the left rear of the knee should only be used when the knee will not be moved.

For 3VS, 3VSII & 3VK



For 3VKH, 5VK & 6VK

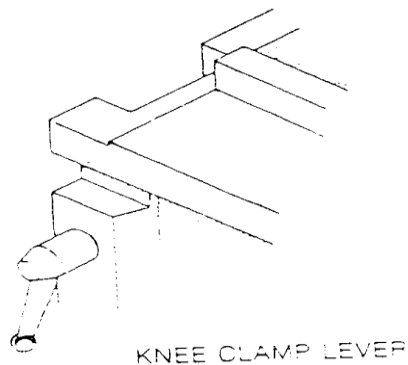

Figure 17. Knee clamping lever

6-17. Operation Recommendations

Use 2, 3, or 4 flute end mills. Eight flute end mills are usually not as satisfactory for general milling. When using shell mills, face mills or any other tooling, proper machining practice should be observed.

For 3VS, 3VSII, 3VK & 3VKH

Power quill feed can be used for drills up to $\frac{3}{8}$ " diameter in mild tool steel. Overload clutch is preset to hold up to 200 lbs. down pressure on quill. Use manual feed for drills over $\frac{3}{8}$ ".

For 5VK & 6VK

Power quill feed can be used for drills up to $\frac{5}{8}$ " diameter in mild tool steel. Overload clutch is preset to hold up to 300 lbs down pressure on quill.

CAUTION
THIS CLUTCH SHOULD NOT BE TAMPERED WITH IN
THE FIELD

CAUTION
DO NOT TRY TO CHANGE SPINDLE SPEED ON E-
MILL VARISPEED HEAD UNTIL MOTOR IS RUNNING.
THIS COULD CAUSE PARTS TO BREAK.

Spindle Feeds are adjusted by turning variable resistor on the front of the belt housing. There are two ranges shown; 60 to 500, and 500 to 4500.

60 to 500 RPM is obtained through the back-gear drive and is referred to as low range. To engage the back-gear, use the lever marked HI-NEUTRAL-LO on the right side of the head. Move this lever to the "LO" position and use low range on the variable speed dial.

When shifting to “LO” DO NOT FORCE THE LEVER if the back-gears do not mesh. Hold the lever so that the gears are clear of one another, rotate the spindle nose by hand until the gears line up, then put the unit in “LO” (back-gear).

500 to 4500 RPM is obtained through the direct drive and is referred to as high range. The same procedure as above is used to select this range, except the HI-NEUTRAL-LO lever is set in the “HI” position.

Wear on the V belt will cause a slight difference between the actual speeds and those shown in dial windows. This can be corrected as follows: Turn the variable resistor knob clockwise until it stops. (This will be near the 4500 reading on the counter.) Use a tachometer to determine the spindle speed, and then adjust the parameter value inside the inverter until the spindle speed registers 4500 on the tachometer.

<p style="text-align: center;">CAUTION DO NOT SHIFT THE HI-NEUTRAL-LO LEVER WHEN THE FEED GEAR IS ENGAGED.</p>

DO NOT LOOSEN the 3 hex nuts on the upper part of the Quill Housing. These are set at the factory and are used only for alignment.

SWIVELING THE VARI-DRIVE may be accomplished by loosening the lower 3 hex nuts attaching the Vari-Drive unit to the quill housing and then swiveling to any desired position. See arrangement of T-Bolts in Gear Housing for this purpose.

<p style="text-align: center;">CAUTION CARE MUST BE TAKEN TO SECURE THE NUTS WHEN THE ATTACHMENT IS IN POSITION, BEFORE THE MOTOR IS TURNED ON.</p>
--

6-18. Safety Accessories for All Models

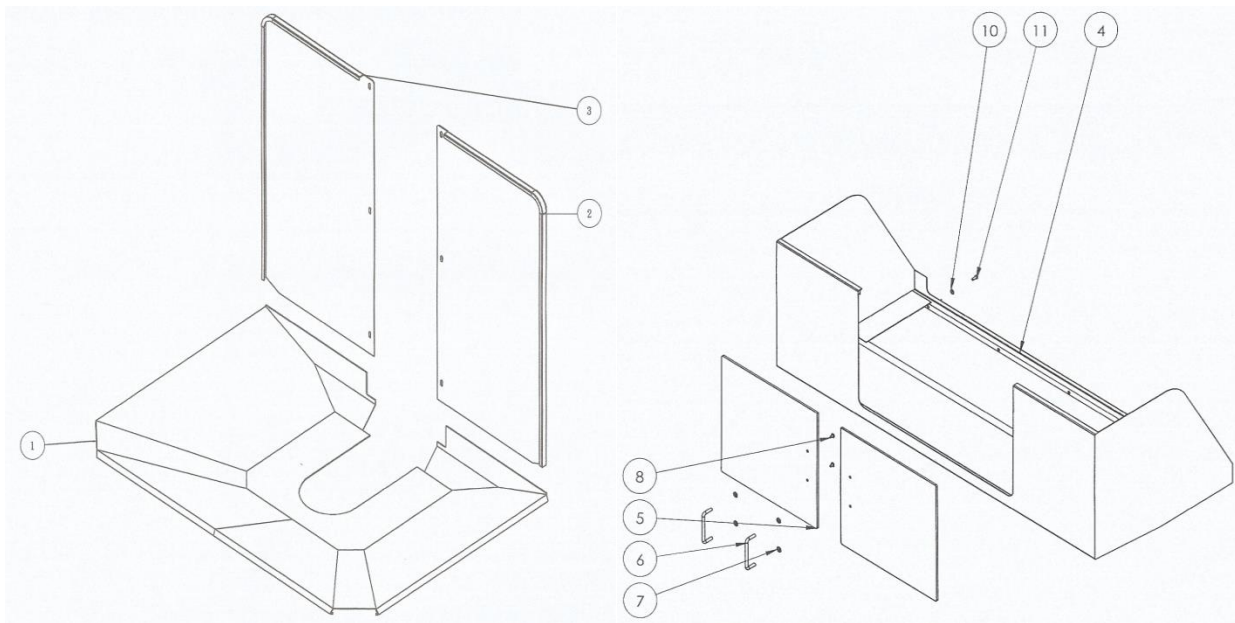

Chip pan, side column guards and table guard assembly

7. MAINTENANCE

7-1 Adjustment of Table Gib:

The table is provided with a full length tapered gib in the saddle, and an adjusting screw on the left side. To take up gib, tighten gib adjusting screw slightly and repeat until a slight drag is felt when moving the table by hand.

For 3VS, 3VSII, 3VK

For 3VKH, 5VK & 6VK

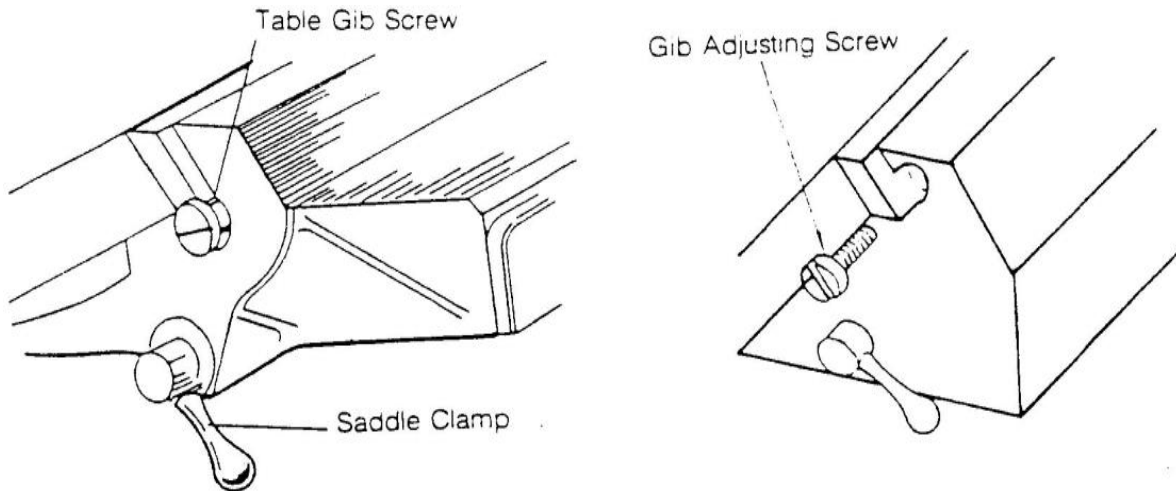

Figure 18. Saddle/table gibs

7-2 Adjustment of Saddle and Knee Gibs

Adjustment of saddle gib

A tapered gib is used for adjusting the saddle bearing on the knee. This forms a guide for the saddle. To tighten gib, remove chip wiper and use the same method as described above. Replace chip wiper after gib has been adjusted.

For 3VS, 3VSII, 3VK

For 3VKH, 5VK & 6VK

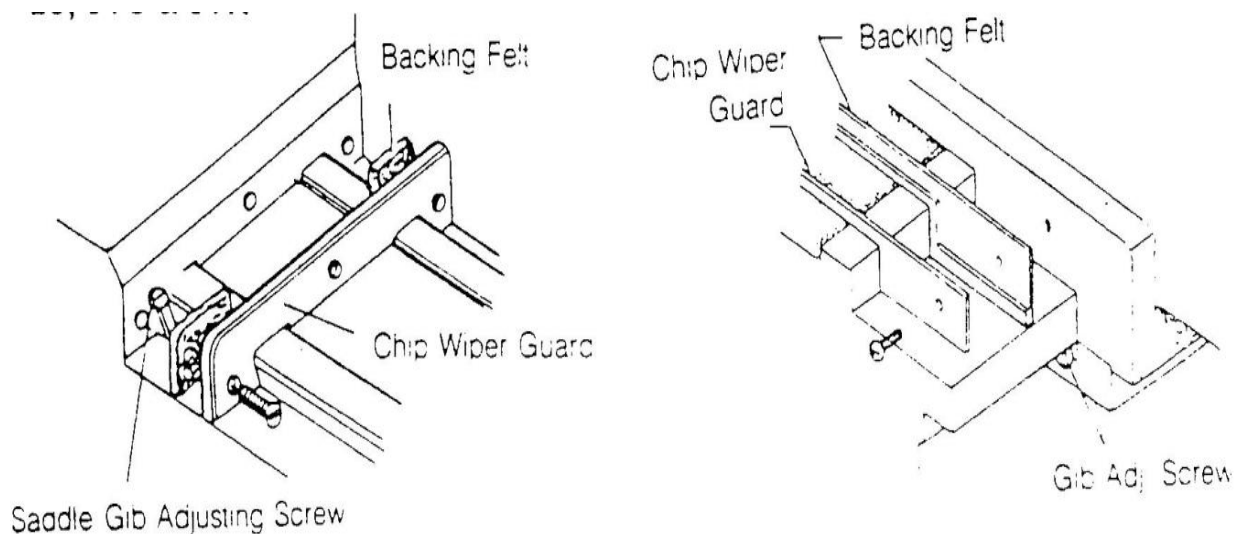
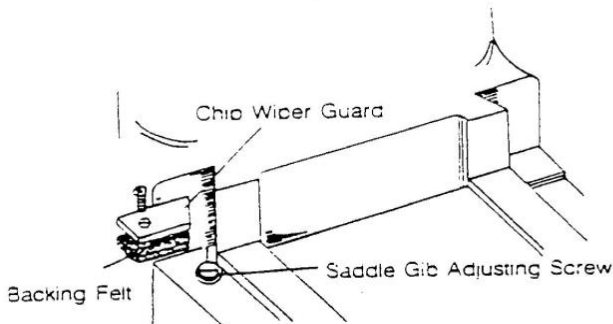

Figure 19. Saddle/knee gibs

Adjustment of knee gib:

Remove chip wiper and adjust screw until smooth movement is attained. Replace chip wiper.

For 3VS, 3VSII, 3VK



For 3VKH, 5VK & 6VK

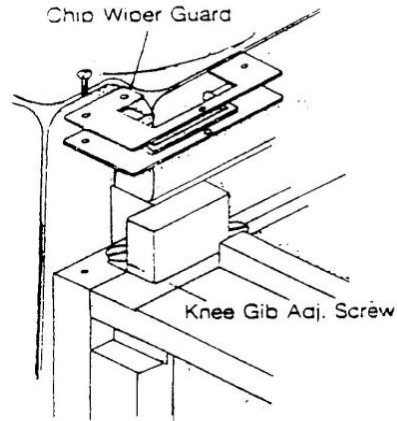

Figure 20. Knee/column gibs

7-3 Removing Table & Saddle

Remove the following: ball crank, handles, dial holders and bearing brackets. Remove the lead screw and slide the table from the saddle.

Removing saddle

Follow the same procedures above; however, it is necessary to remove the entire front bracket assembly. Next, remove the cross feed nut bracket with can only be done by remove the table.

7-4 Leadscrew Backlash Adjustment

For 3VS, 3VSII, 3VK, 3VKH & 5VK

Table leadscrew adjustment

Crank the table to the left, loosen 3 screws, turn adjusting nut while slowly turn handle until 0.004" or 0.005" is obtained, then tighten 3 screws again.

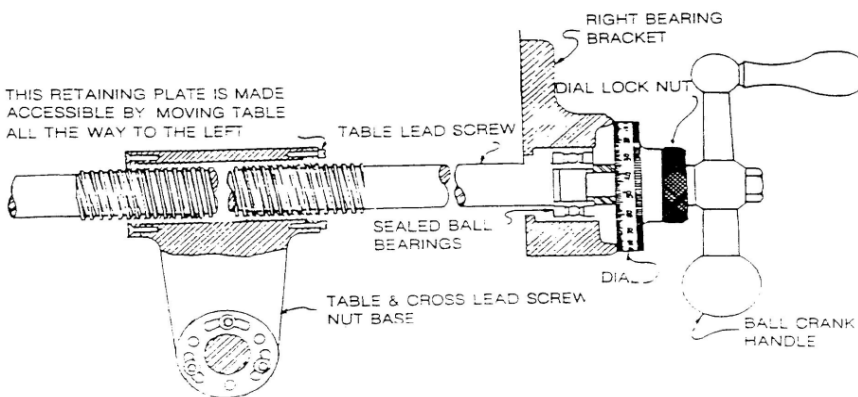

Figure 21. Table leadscrew assembly

Cross leadscrew adjustment

Crank the saddle to middle position, withdraw 4 screws "D", pull the saddle forward to expose screws "B", unscrew screw "B" a few turns, slowly turn handle "C" while tightening adjusting nut until 0.004" or 0.005" is obtained. Lock screw "B" into tight position again, move the saddle to front and retighten 4 screws.

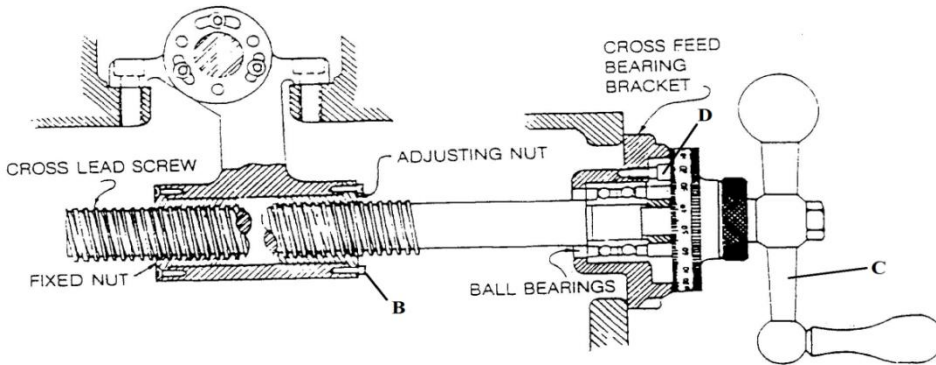
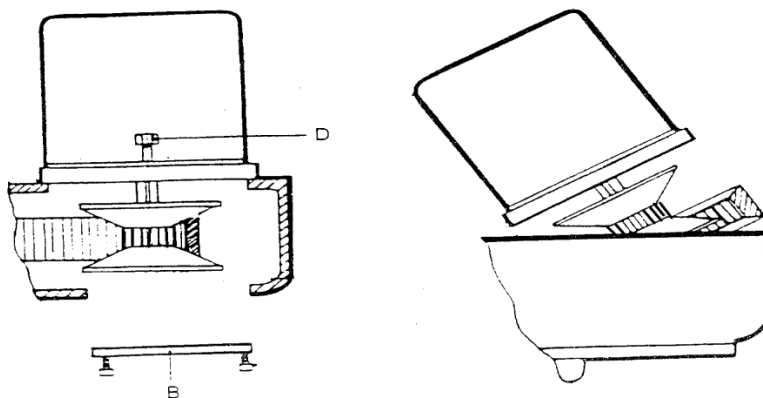

Figure 22. Crossfeed leadscrew assembly

7-5 Removing the Motor

Run the head at the lowest speed of both range and shut off the motor. This puts the V belt in the position for disassembly.

1. DISCONNECT THE POWER and then remove the limit switch from the left side of the belt housing.
2. Remove the cover (B) at the lower end of the motor shaft.
3. Remove the three screws and lift out the top bearing cap.
4. Now remove the screws (D) that fasten the motor to the belt housing. The motor should be lifted slightly, tilt away from the spindle and toward the rear end of the belt housing. This will put the V belt into a loosening position between the two pulleys, and providing the slack needed to ship the V belt over the motor pulley.
5. Now lift the motor high enough to rest the motor base GENTLY on the top edge of the belt housing toward the spindle side. The V belt now can be slipped off the motor pulley and the motor can be removed from the housing.



Removing motor

7-6 Changing the Vari-drive Belt—the V Belt

Complete the previous procedures for removing the motor then remove the three screws (A) and lift out the top bearing cap (B). Next remove the six screws (D), then holding the belt housing (E) to the base.

Remove the old belt and replace it with a new belt. Do use a same specification V belt from other manufacturers, otherwise vibration and heat could result from the use of the wrong belt.

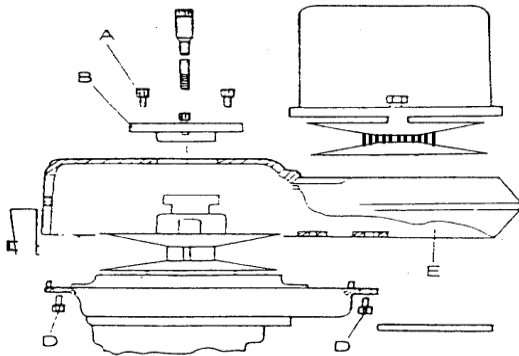

Changing vari-speed V belt

7-7 Changing Timing Belt

Complete the operation for removing the motor, then put the HI-NEUTRAL-LO lever in the “LO” position. Remove the drawbar (A) and lower the spindle.

Remove the six screws holding the upper and lower belt housings together including the two lower screws (C) in speed changer housing just below the switches.

A slight blow under the speed change housing may be needed to separate the upper belt housing (D) from its base.

As the housings are being separated the timing belt (E) will still be connected to both, resisting the separating movement. The separation can be assisted by gently pushing the belt off the large pulley as the upper housing is being raised.

Remove the old belt and replace with a new belt.

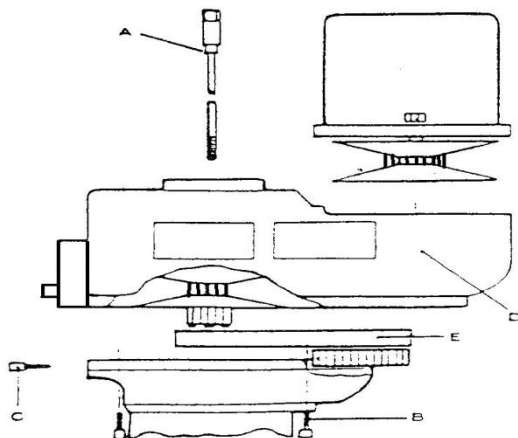

7-8 Returning Spring Replacement

Move quill to top position and apply quill lock, remove screw (A), hub (B) and key (C) and screws (D), allowing housing to rotate slowly releasing spring tension. Lift end of spring from peg on the pinion shaft. Rotate Housing (E) counter-clockwise from head casting, remove spring from housing. Refit spring to main housing casting turning housing clockwise until spring locates on peg in the pinion shaft.

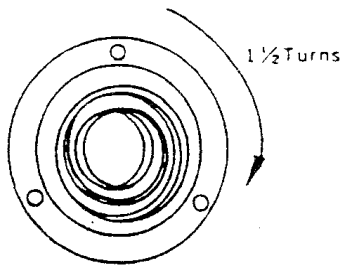
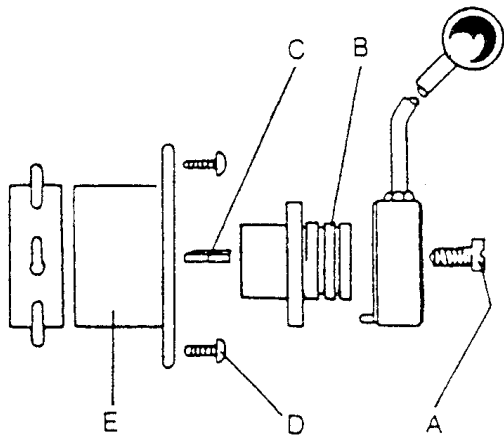

Clock Spring Replacement

7-9. Recommended Spare Part List

Spare parts are always a concern for the users. Below lists are recommended by the manufacturer. The time frame for the using the spare parts are estimated at one to two years depending on the machines' usage. Please carefully select and purchase the parts needed for individual mill.

Note: These lists are for reference only! Please use them as needed.

A. For regular e-mill 3VS, 3VSII, 3VK, 3VKH & 5VK

Recommended Spare Part List for 3HP Milling Head

Part #	Factory#	Description		Specification	Brand
9556	F1	Fuse 1		3A	TEND
9557	F2	Fuse 2		3A	TEND
9512		Transformer Single 230V	1Q24VA	24VA	
9512-1		Transformer Single 460V			
9554	Relay	Relay	MY-2NJ	AC24V	OMRON
9555	S1	HI/LOW GEAR SW	SHL-Q2255	AC-15 2A 125V	OMRON
9510-2	FAN	Cooling Fan	GA1123XBL	AC110/120V 18/19W	GULF
9507-4		5HP Magnetic Contactor 110	C-12D10D7	220V 3P 5.5HP	NHD
6092		Bearing 6206	6206		FAG
6093		Bearing 7207	7207	7207x2	SKF
7041	VS77	Bearing 6908ZZ	6908	6908x2	NSK
7079	VS65	Bearing 6203ZZ	6203	6203x2	NSK
8023	VS43	Ball Bearing 6010	6010		FAG
8004	VS15	Ball Bearing 6207	6207		NSK
8027-1	VS04-1	V Belt		31.5"	
7036	VS63	Timing Belt		225L	
7083	VS66	Bull Gear Pinion			
7040	VS74	Spindle Bull Gear			
8032	VS47	Brake Shoe Assembly			
8034-5	VS70-1	Spindle Pulley Hub			
7039	VS73	Spindle Gear Hub			
7057	VS75	Bearing Sleeve Spacer			
6181	B178	Clock Spring			
MP6139	B1+17	Feed Bevel Gear Assembly			

B. For regular e-mill 6VK

Recommended Spare Part List for 5HP Milling Head

Part #	Factory#	Description	Specification	Brand
9556	F1	Fuse 1	3A	TEND
9557	F2	Fuse 2	3A	TEND
9512		Transformer Single 230V	24VA	
9512-1		Transformer Single 460V		
9554	Relay	Relay	AC24V	OMRON
9555	S1	HI/LOW GEAR SW	AC-15 2A 125V	OMRON
9510-2	FAN	Cooling Fan	AC110/120V 18/19W	GULF
9507-4		5HP Magnetic Contactor 110V	220V 3P 5.5HP	NHD
5K-6092		Ball Bearing 6008LLB	6008x2	FAG
5K-6093		Ball Bearing 7010	7010x2	NSK
5E7041	FVS77	Bearing 6910VV	6910x2	NSK
7079	VS65	Bearing 6203ZZ	6203x2	NSK
5E8023	FVS43	Ball Bearing 6013VV		FAG
5E8004	FVS15	Ball Bearing 6209ZZ		NSK
5E8027-1	FVS04-1	3V Belt	Belt x 2	
5E7036	FVS63	Timing Belt		
7083	VS66	Bull Gear Pinion		
5E7040	FVS74	Spindle Bull Gear		
5E8032	FVS47	Brake Shoe Assembly		
5E8034-5	FVS70-1	Spindle Pulley Hub		
5E7039	FVS73	Spindle Gear Hub		
5E7048	FVS75	Ball Bearing Gear Sleeve		
5K-6181	FB178	Clock Spring		

C. For UL listing e-mill 3VS, 3VSII, 3VK, 3VKH & 5VK

UL Recommended Spare Part List for 3HP Milling Head

Part #	Factory#	Description		Specification	Brand
9550	FU1	Circuit Breaker		FAZ-C20/3-NA/1	EATON (Moeller)
9551	FU2,FU3	Circuit Breaker		FAZ-S1/1	EATON (Moeller)
9552	FU3	Fuse	KTK/5A	1P-600V/20KA	BUSSMANN
9553	FR2	Thermal Over Load Relay	Moeller	ZB12-0.6	SCHNEIDER
9512-2	TR 1	Control Transformer	TS01C	TS01C-50VA	LUNG GHI
9554	Relay	Relay	MY-2NJ	AC24V	OMRON
9555	S1	HI/LOW GEAR SW	SHL-Q2255	AC-15 2A 125V	OMRON
9510-2	FAN	Cooling Fan	GA1123XBL	AC110/120V 18/19W	GULF
6092		Bearing 6206	6206		FAG
6093		Bearing 7207	7207	7207x2	SKF
7041	VS77	Bearing 6908ZZ	6908	6908x2	NSK
7079	VS65	Bearing 6203ZZ	6203	6203x2	NSK
8023	VS43	Ball Bearing 6010	6010		FAG
8004	VS15	Ball Bearing 6207	6207		NSK
8027-1	VS04-1	V Belt		31.5"	
7036	VS63	Timing Belt		225L	
7083	VS66	Bull Gear Pinion			
7040	VS74	Spindle Bull Gear			
8032	VS47	Brake Shoe Assembly			
8034-5	VS70-1	Spindle Pulley Hub			
7039	VS73	Spindle Gear Hub			
7057	VS75	Bearing Sleeve Spacer			
6181	B178	Clock Spring			
MP6139	B1+17	Feed Bevel Gear Assembly			

Original Components List

	ACER	UL Model:	3VS, 3VSII, 3VK, 3VKH, 5VK, 6VK		
PART #	ITEM NAME	PARTS NAME	MAKER	PARTS CATALOG NUMBER	QTY
9505-1	SB4	Limit Switch	Azbil	LCB1-501 10A 250VA	1
9507-10	SPINDLE MODULE	Inverter	Toshiba	VF-S15 230V	1
9507-11	SPINDLE MODULE	Inverter	Toshiba	VF-S15 460V	1
9506-10	Resistor 1	Braking Resistors		230VZQR450W 6.5Ω	3
9506-11	Resistor 1	Braking Resistors		460V ZQR450W 20Ω	3
9514		Relay	OMRON	MY-2NJ AV24V	1
9570	TR 1	Transformer	LUNG GHI	TS01C-50VA	1

Replacement Components List

9505-2	SB4	Limit Switch	OMRON	D4E-1A20N	1
9507-16	SPINDLE MODULE	Inverter	Fuji	FRN0020E2S-2GB 230V	1
9507-17	SPINDLE MODULE	Inverter	Fuji	FRN0020E2S-4GB 460V	1
9506-16	Resistor 1	Braking Resistors		230V ZQR450W 11Ω	3
9506-17	Resistor 1	Braking Resistors		460V ZQR450W 43.3Ω	3
9514-1		Relay	OMRON	MY2N-GS AC24V	1
9570-2	TR 1	Transformer	Shin Hsing	SHAT-55C-H 55VA1ΦH	1

D. For UL listing e-mill 6VK

UL Recommended Spare Part List for 5HP Milling Head

Part #	Factory#	Description		Specification	Brand
9556	FU1	Fuse	FNQ/30A	3P-600A/20KA	BUSSMANN
9557	FU2	Fuse	KTK/5A	1P-600V/20KA	BUSSMANN
9558	FU3	Fuse	KTK/5A	1P-600V/20KA	BUSSMANN
9559	FR1	Spindle Overload Relay	LR3D21	12-18A/15A	SCHNEIDER
9560	FR2	Coolant Overload Relay	LR3D03	0.25-0.4A/0.38A	SCHNEIDER
9561	FR4	Up/Down Overload Relay	LR3D14	7-10A/8A	SCHNEIDER
9512-3	TR1	Transformer	LCP-TBS	JY- 270/500VA 0-480V/0-110V	LUNG GHI
9554	Relay	Relay	MY-2NJ	AC24V	OMRON
9555	S1	HI/LOW GEAR SW	SHL-Q2255	AC-15 2A 125V	OMRON
9510-2	FAN	Cooling Fan	GA1123XBL	AC110/120V 18/19W	GULF
5K-6092		Ball Bearing 6008LLB	6008	6008x2	FAG
5K-6093		Ball Bearing 7010	7010	7010x2	NSK
5E7041	FVS77	Bearing 6910VV	6910	6910x2	NSK
7079	VS65	Bearing 6203ZZ	6203	6203x2	NSK
5E8023	FVS43	Ball Bearing 6013VV	6013		FAG
5E8004	FVS15	Ball Bearing 6209ZZ	6209		NSK
5E8027-1	FVS04-1	3V Belt		Belt x 2	
5E7036	FVS63	Timing Belt			
7083	VS66	Bull Gear Pinion			
5E7040	FVS74	Spindle Bull Gear			
5E8032	FVS47	Brake Shoe Assembly			
5E8034-5	FVS70-1	Spindle Pulley Hub			
5E7039	FVS73	Spindle Gear Hub			
5E7048	FVS75	Ball Bearing Gear Sleeve			
5K-6181	FB178	Clock Spring			

Original Components List

ACER		UL Model: 3VS, 3VSII, 3VK, 3VKH, 5VK, 6VK			
PART #	ITEM NAME	PARTS NAME	MAKER	PARTS CATALOG NUMBER	QTY
9505-1	SB4	Limit Switch	Azbil	LCB1-501 10A 250VA	1
9507-10	SPINDLE MODULE	Inverter	Toshiba	VF-S15 230V	1
9507-11	SPINDLE MODULE	Inverter	Toshiba	VF-S15 460V	1
9506-10	Resistor 1	Braking Resistors		230VZQR450W 6.5Ω	3
9506-11	Resistor 1	Braking Resistors		460V ZQR450W 20Ω	3
9514		Relay	OMRON	MY-2NJ AV24V	1
9570	TR 1	Transformer	LUNG GHI	TS01C-50VA	1

Replacement Components List

9505-2	SB4	Limit Switch	OMRON	D4E-1A20N	1
9507-16	SPINDLE MODULE	Inverter	Fuji	FRN0020E2S-2GB 230V	1
9507-17	SPINDLE MODULE	Inverter	Fuji	FRN0020E2S-4GB 460V	1
9506-16	Resistor 1	Braking Resistors		230V ZQR450W 11Ω	3
9506-17	Resistor 1	Braking Resistors		460V ZQR450W 43.3Ω	3
9514-1		Relay	OMRON	MY2N-GS AC24V	1
9570-2	TR 1	Transformer	Shin Hsing	SHAT-55C-H 55VA1ΦH	1

7-10. Recommended Maintenance Schedule

7-10-1. Daily maintenance:

1. Check the oil level of lubrication pump. Add more if it is below low level.
2. Check all lubrication points to see if oil is present?
3. Check coolant pump to see if it is still operational? (6VK only)
4. Remove all movable items from the machine to reduce the chance of accidental damaging the machine and injuring the operator.
5. After each day's work, clean the machine's table, machine's surfaces and lubricate all moving parts.
6. Spindle taper must be clean and lubricated at the end of each day.

7-10-2. Weekly maintenance:

1. Please use clean rugs or paper towels to clean halogen light, operation panel and control panel to keep them readable.
2. Clean air filter within cooling fan unit.
3. Make sure spindle taper is smooth and chip-less.
4. Check all lubrication point and lubrication pump to see if they are function normally?
5. Check coolant level, add if necessary! (6VK only)
6. Listening to sound generated from the machine, pay particular attention to unusual noise from head housing, spindle and fan!
7. Re-level the machine with precision engineering levels to see if the machine is still within specification. (Do this for the first three months after machine's installation!)

7-10-3. Six month maintenance

1. Check taper run-out of spindle to see if it is still within accuracy?
2. Check all machine's screws and nuts to see if they are still right?
3. Check tightness of the gibs. Are they still within specification?
4. Inspect all electrical terminals and wires. Make sure they are normal and functional. Clean the dust within the electric cabinet.
5. Check tension of the V-belt on the top housing. Adjust if necessary.
6. Re-level the machine with precision engineering levels again to ensure machine's accuracy.
7. Inspect surrounding areas, clean and remove unused items if necessary!

7-10-4. Yearly maintenance

1. Check all components on the operation and control panel to see if they are still sensitive?
2. Remove all carbon deposit on all magnetic contactors.
3. Replace coolant liquid with new ones to reduce chance of generating odor.
4. Clean and replace lubrication pump's oil reservoir with new waylube oil.

5. Replace V-belt on the top housing to ensure power transferring efficiency.
6. Check all function on the machine, ie, automatic downfeed, spindle RPM, etc., to ensure machine's workability.
7. Clean all leadscrews, and replace with new lubricant.
8. Remove all gibs, clean, and re-install them to original specification.
9. Check leveling and adjust the machine to maintain machine's accuracy.

7-10-5. Points to watch on doing maintenance

1. All scheduled maintenance must be exercised and recorded.
2. During mechanical maintenance such as gibs adjustment, etc., all power supply must be shut-off to prevent accidental injury.
3. When opening and inspecting electric cabinet, operation and control panel, power sources must be turn or shut off to prevent accidental electrocution.
4. In any unable maintenance situation, please contact authorized distributor or manufacturer.
5. Before doing any maintenance work, maintenance personnel must concur with operation manual to observe safety precaution. This is to reduce accidental injury.

7-11. Tables for Material Cutting Information

GENERAL SPEED RECOMMENDATIONS

Material to be Cut	Feet Per Minute		
	Rough Cut	Rough and Finish	Light and Finish Cut
Cast Iron - Soft (Under 200 Brinnell)	70	80-90	120
Cast Iron - Med (200-300 Brinnell)	55	60-70	90
Cast Iron - Hard (Over 300 Brinnell)	40	50-60	70
Steel (Chrome Nickel 40 -45 Shore)	30	40	50
Steel (Stainless)	60	80	90
Steel (Low Carbon)	80	90	140
Steel (High Carbon)	40	50	70
Bronze (Medium)	90	120	150
Bronze (Hard)	65	90	130
Brass (Hard)	100	150	200
Copper	150	200	300
Duraluminum	400		600
Aluminum	600		1000

TABLE OF CUTTING SPEEDS AND FEEDS

Feet Per Minute	15	20	25	30	40	50	60	70	80	90	100
Diameter, Inches	Revolutions Per Minute										
1/16"	91	122	152	183	244	305	366	427	488	550	611
	7		8	3	5	6	7	8	9	0	2
1/8"	45	611	764	917	122	152	183	213	244	275	305
	8				2	8	3	9	5	0	6
3/16"	30	407	509	611	815	101	122	142	163	183	203
	6					9	2	6	0	3	7
1/4"	22	306	382	458	611	764	917	107	137	137	152
	9							0	5	5	8
5/16"	18	244	306	367	489	611	733	856	978	110	122
	3									0	2
3/8"	15	204	255	306	407	509	611	713	815	917	101
	3										9
7/16"	13	175	218	262	349	437	524	611	698	786	873
	1										
1/2"	11	153	191	229	306	382	458	535	611	688	764
	5										
5/8"	91	122	153	183	244	306	367	428	489	550	611
3/4"	76	102	127	153	204	255	306	357	407	458	509
7/8"	64	87	109	131	175	218	262	306	349	393	437
1"	57	76	95	115	153	191	229	267	306	344	382
1 1/8"	50	67	84	102	136	170	204	238	272	306	340
1 1/4"	45	61	76	91	122	153	183	214	244	275	306
1 3/8"	41	55	69	83	111	139	167	194	222	250	278
1 1/2"	38	50	63	76	102	127	153	178	204	229	255
1 5/8"	35	47	58	70	94	118	141	165	188	212	236
1 3/4"	32	43	54	65	87	109	131	153	175	196	218
1 7/8"	30	40	50	61	81	102	122	143	163	183	204
2"	28	38	47	57	76	95	115	134	153	172	191

8. Mechanical Drawings & Parts Breakdown List

Note: When ordering parts, please be prepared with,

1. Machine model & serial number.
2. Item number.
3. Part number and description.
4. Year of Production.
5. Voltage & horsepower.
6. Quantity

8-1 3HP (MILLING HEAD)

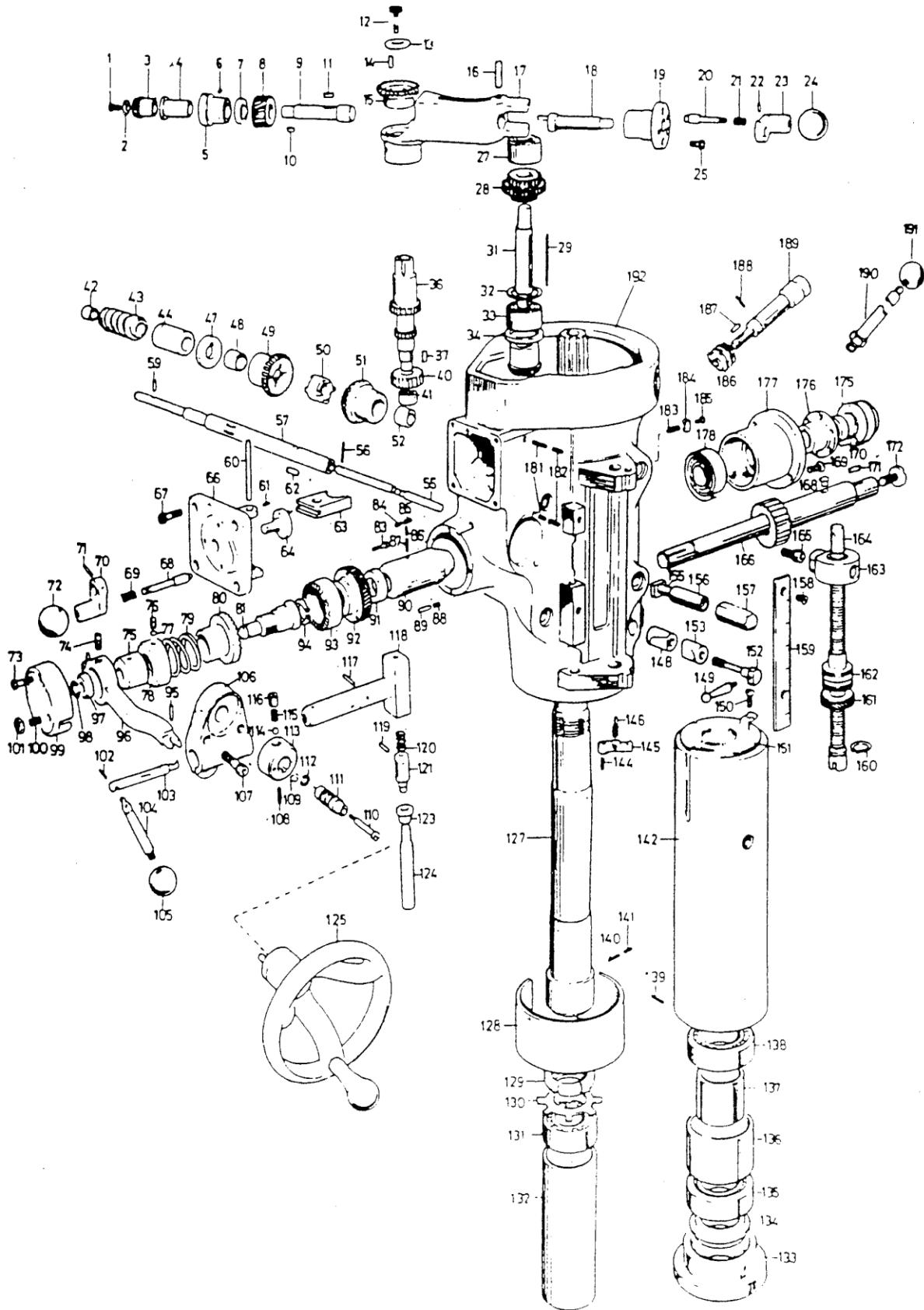

3HP (MILLING HEAD)

ITEM NO.	PARTS NO.	FACTORY NO.	DESCRIPTION	QT'Y
1	6141	B1+17	RD.HD Screw	1
2	6140		Bevel Pinion Washer	1
3	6139	B03	Feed Bevel Pinion	1
4	6183		Feed Worm Gear Shaft Sleeve	1
5	6137	B05	Worm Cradle Bushing	1
6	6123		Set Screw	1
7	6136		Worm Gear Spacer	4
8	6134	B08	Fed Drive Worm Gear	1
9	6133		Feed Drive Worm Gear Shaft	1
10	6142		Worm Shaft Key	1
11	6135		Key	1
12	6150		Lock Nut	1
13	6149		Washer	1
14	6147		Cluster Gear Key	1
15	6148	B15	Feed Reverse Bevel Gear	1
16	6122	B16	Feed Engage Pin	1
17	6121	B17	Worm Gear Cradle	1
18	6126	B18	Worm Gear Cradle Throw-out	1
19	6125	B19	Shift Sleeve	1
20	6169	B20	Gearshift Plunger	1
21	6170	B21	Compression Spring	1
22	6128		Roll Pin 3X20	1
23	6168	B23	Shift Crank	1
24	6131	B24	Black Plastic Ball	1
25	6132		Cap Screw 5X12	3
27	6157	B27	Cluster Gear Shaft Upper Bearing	1
28	6153	B28	Cluster Gear Assembly	1
29	6160		Cluster Gear Key 3X3X45	1
31	6151	B31+35	Cluster Gear Shaft	1
32	6158		Snap Ring 16	1
33	6156	B33	Bevel Gear Bearing	1
34	6159	B34	Bevel Gear Thrust Spacer	1
36	6143	B36+38	Feed Driving Gear	1
37	6145		Key	1
40	6144		Feed Drive Gear	1

3HP (MILLING HEAD)

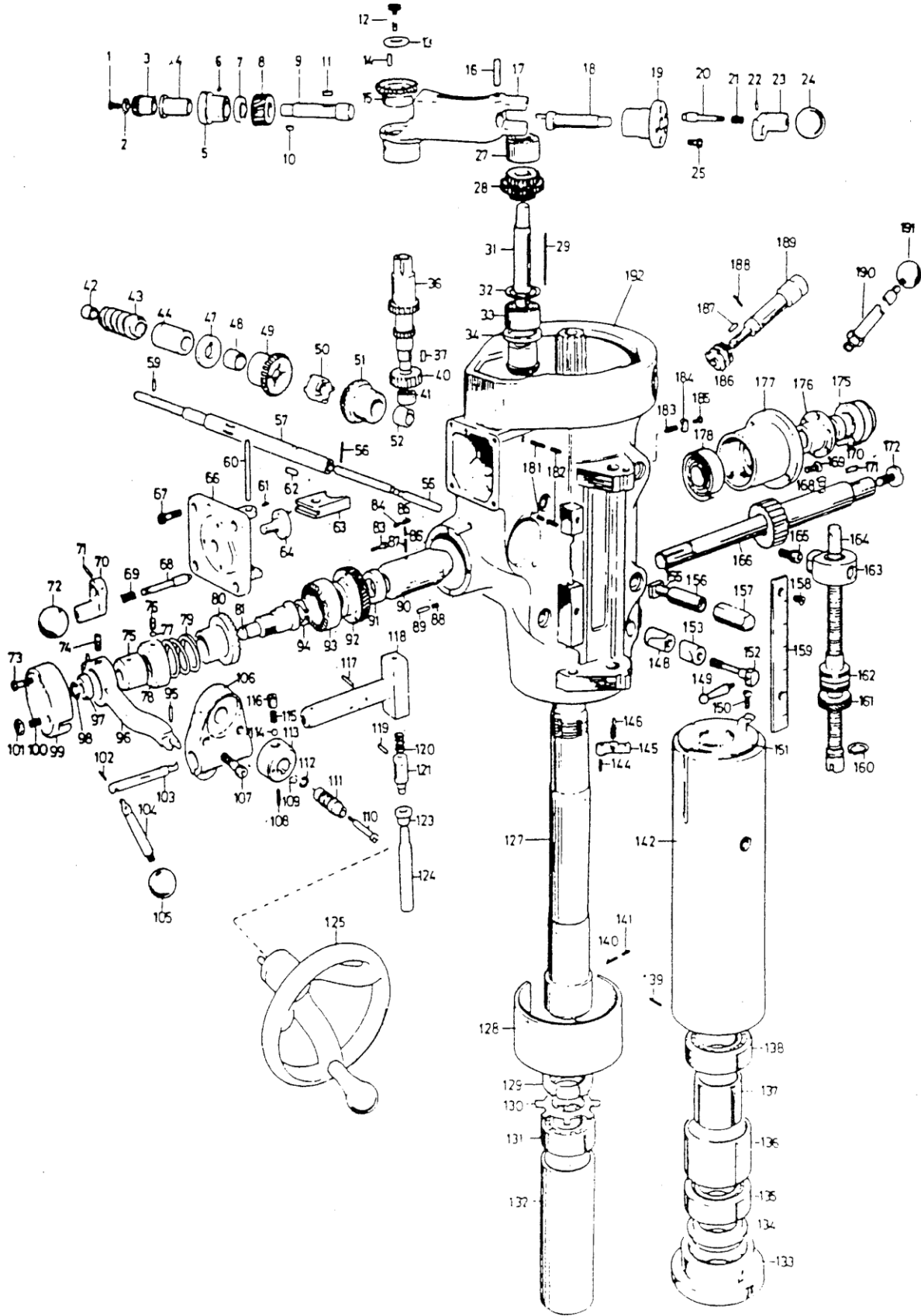

3HP (MILLING HEAD)

ITEM NO.	PARTS NO.	FACTORY NO.	DESCRIPTION	QT'Y
41	6252		Needle Bearing #BA66	1
42	6227	B42	Bushing	1
43	6225	B43	Worm	1
44	6224	B44	Feed Worm Shaft Bushing	1
47	6223	B47	Feed Worm Shaft Thrust Washer	1
48	6221	B48	Bushing	1
49	6220	B49	Feed Reverse Bevel Gear	1
50	6222	B50	Feed Reverse Clutch	1
51	6220		Feed Reverse Bevel Gear	1
52	6221		Bushing	1
55	6216	B55	Reverse Clutch Rod	1
56	6217		Roll Pin 3X20	1
57	6209	B57	Feed Worm Shaft	1
59	6226		Pin 3X10	1
60	6163	B60	Feed Shift Rod	1
61	6164		KP.Set Screw 5X5	1
62	6230		Key	1
63	6162	B63	Feed Gear Shift Fork	1
64	6166	B64	Cluster Gear Shift Crank	1
66	6161	B66	Cluster Gear Cover	1
67	6165		Cap Screw 5X12	4
68	6169		Gear Shift Plunger	1
69	6170		Comperession Spring	1
70	6168		Shift Crank	1
71	6167		Roll Pin	1
72	6171		Black Plastic Ball	1
73	6206		Cap Screw	2
74	6202	B74	Clutch Ring Pin	2
75	6200	B75	Clutch Ring	1
76	6199		Socket Set Screw	1
77	6199-1		Brass Plug	1
78	6198	B78	Overload Clutch Lock Nut	1
79	6197	B79	Safety Clutch Spring	1
80	6194	B80	Overload Clutch	1
81	6195	B81	Overload Clutch Sleeve	1

3HP (MILLING HEAD)

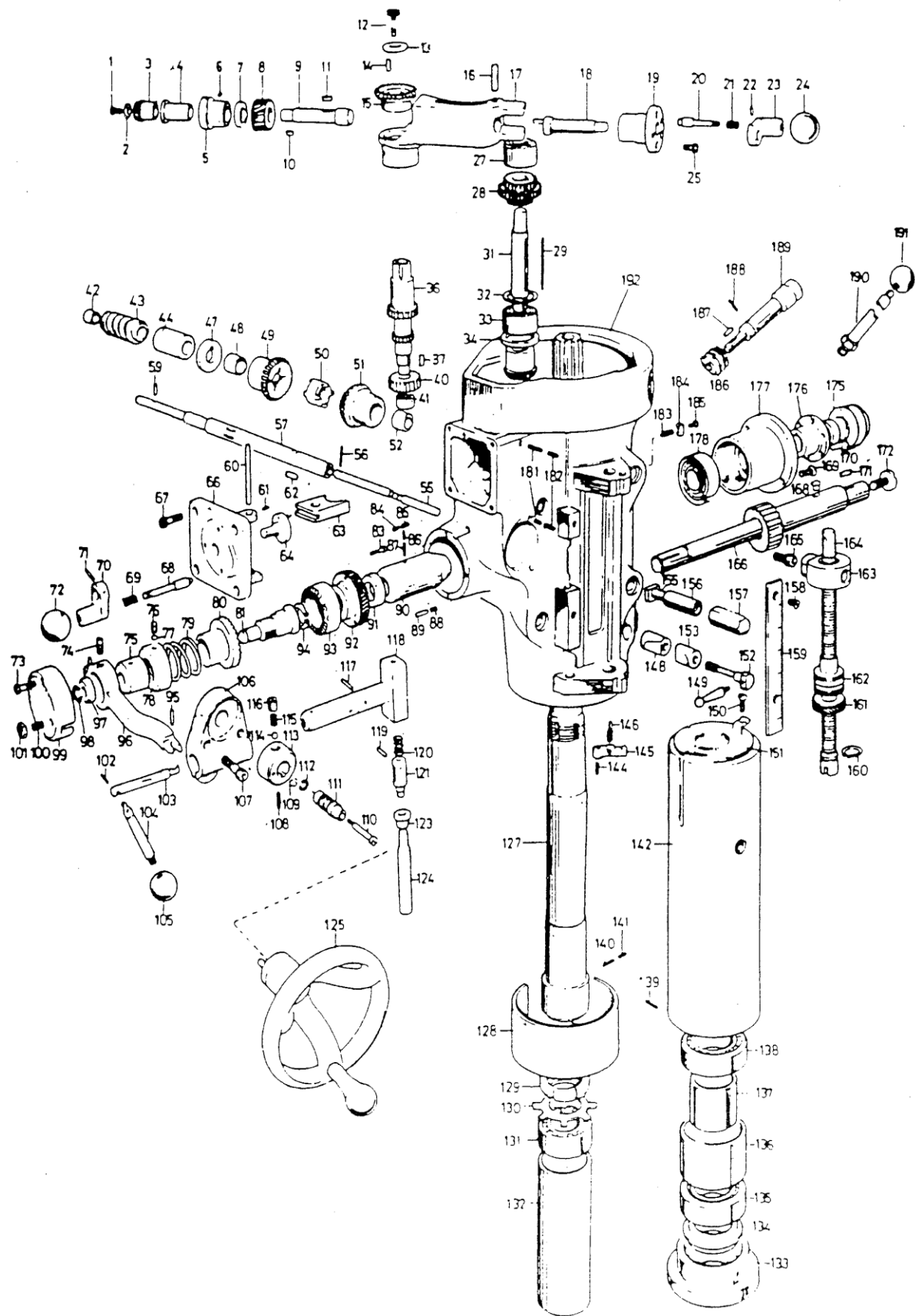

3HP (MILLING HEAD)

ITEM NO.	PARTS NO.	FACTORY NO.	DESCRIPTION	QT'Y
83	6189		Round Head Screw	3
84	6228		Mock-it Lock Scrw	1
85	6228		Socket Set Screw	1
86	6246		Lock Screw	1
87	6246-1		Socket Set Screw	1
88	6191	B88	Compression Spring	1
89	6193	B89	Overload Clutch Lever Spring Plunger	1
90	6186	B90	Quill Pinion Shaft Bushing	1
91	6190	B91	Pinion Shaft Worm Gear Spacer	1
92	6187	B92	Overload Clutch Worm Gear	1
93	6188	B93	Overload Clutch Ring	1
94	6188-1		Snap Ring 15	1
95	6236-1	B95	Dowrl Pin	1
96	6203	B96	Overload Clutch Trip Lever	1
97	6201	B97	Overload Clutch Washer	1
98	6195-1		Snap Ring 10	1
99	6205	B99	Clutch Arm Cover	1
100	6207		Socket Set Screw	1
101	6208		Chem Blacked Lock Nut	1
103	6239	B103	Cam Rod	1
104	6234	B104	Trip Handle	1
105	6233	B24	Black Plastic Ball	1
106	6231	B106	Feed Trip Braket	1
107	6232		Cap Screw 6X20	2
108	6219		Socket Set Screw 6X6	1
109	6229		Key	1
110	6214	B110+111	Feed Reversd Knob Stud	1
111	6213	B110+111	Reverse Knob	1
112	6215	B110+111	Snap Ring "C"	1
113	6218	B113	Handwheel Clutch	1
114	6255		Steel Ball 3/16	1
115	6219-2	B115	Compression Spring	1
116	6219-1		Handwheel Clutch Spring Screw 8X6	1
117	6237		Roll Pin	1

3HP (MILLING HEAD)

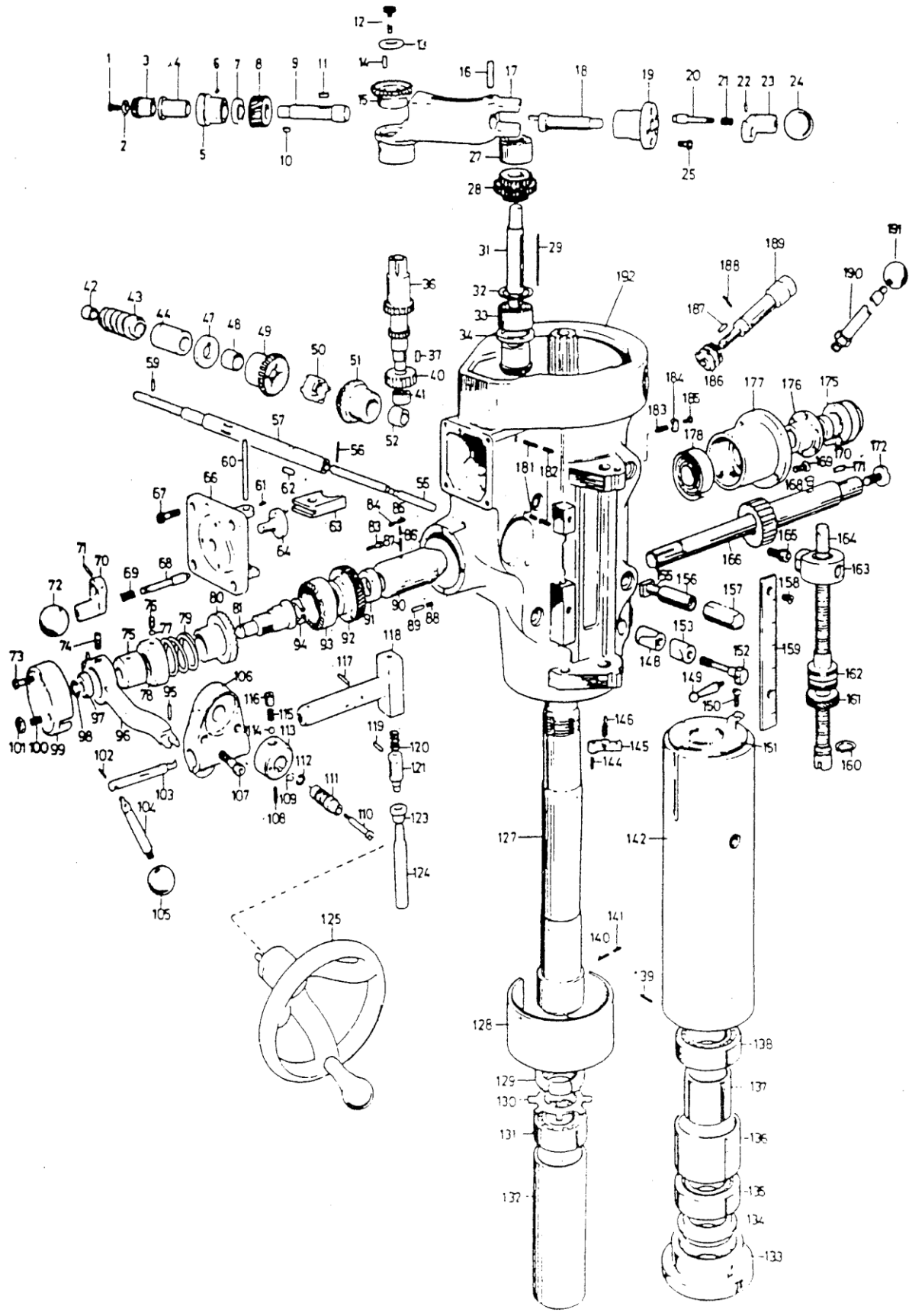

3HP (MILLING HEAD)

ITEM NO.	PARTS NO.	FACTORY NO.	DESCRIPTION	QT'Y
118	6236		Cam Rod Sleeve Assy	1
119	6241		Roll Pin	1
120	6242	B120	Compression Spring	1
121	6240	B121	Trip Plunger	1
123	6118-1		Trip Plunger Bushing	1
124	6118	B124	Feed Trip Plunger	1
125	6210	B125+126	Handwheel	1
127	6084	B127	Spindle	1
128	6086	B128	Quill Skirt	1
129	6090	B129	Lock Nut	1
130	6091		Lock Washer	1
131	6092		Bearing 6206	1
132	6094		Sleeve	1
133	6098	B133	Nose-Piece	1
134	6097	B134	Spindle Dirt Shield	1
135	6093		Bearing 7207	1
136	6095	B136	Bearing Spacer-Large	1
137	6096	B137	Bearing Spacer-Small	1
138	6093		Bearing 7207	1
140	6253	B140	Collet Alignment Screw	1
141	6254		Socket Set Screw	1
142	6085	B142	Quill	1
144	6113		Socket Set Screw 4X20	1
145	6111	B145	Feed Trip Lever	1
146	6112	B146	Trip Lever Pin	1
148	6116-1	B148	Quill Lock Sleeve	1
149	6119	B149	Lock Handle	1
151	6088	B151	Felt Washer	1
152	6117	B152	Quick Lock Bolt	1
152-1	6117-1	B152-1	Spring	1
153	6116	B153	Quill Lock Sleeve Tapped	1
155	5036	B155	T-Bolt Assy	1
156	6120	B156	Lower Clamping Bolt Spacer	2
157	5038	B157	Lock Nut	1
158	6244		Chem Blacked RD.HD.Screws 16	2

3HP (MILLING HEAD)

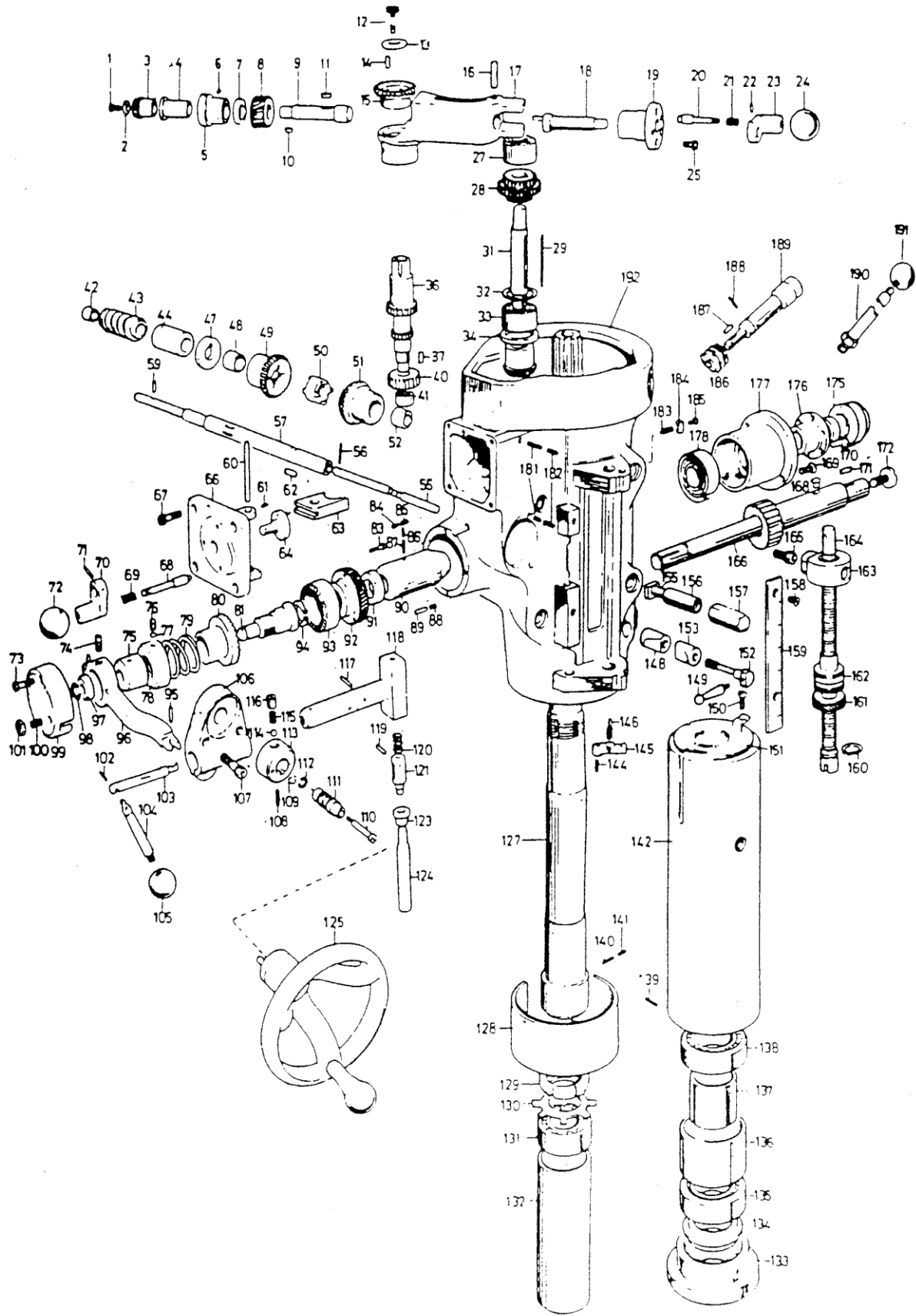

3HP (MILLING HEAD)

ITEM NO.	PARTS NO.	FACTORY NO.	DESCRIPTION	QT'Y
159	6243	B159	Micrometer Scale	1
160	6115		Snap Ring 16	1
161	6108	B161	Quill Micro-stop Nut	1
162	6107	B162	Micrometer Nut	1
163	6105	B163	Quill Stop Knob	1
164	6104	B164	Quill Stop Micro-Screw	1
165	6106		Screw 3/8	1
166	6172	B166	Quill Pinion Shaft	1
168	6185	B168	Spring Pin 5X12	1
169	6180-1		RD.Head Screw	1
170	6179		Roll Pin	1
171	6184		Key 3X3X20	1
172	6183	B172	Pinion Shaft Hub Screw	1
173	6176		Steel Ball	1
174	6175	B174	Compression Spring	1
175	6178	B175	Rack Feed Handle Hub	1
176	6182	B176	Pinion Shaft Hub Sleeve	1
177	6180	B177	Spring Cover	1
178	6181	B178	Clock Spring (Clock Spring Assy.)	1
181	6246-1		Socket Set Screw	1
182	6246		Lock Screw	1
183	6110	B183	Reverse Trip Ball Lever	1
184	6109	B184	Feed Reverse Trip Plunger	1
185	6114	B185	Reverse Trip Ball Lever Screw	1
186	5039	B186	Worm Gear	1
187	5041		Key 4X4X18	1
188	5042		Socket Set Screw	1
189	5040	B189	ADJ Worm Shaft	1
190	6174	B190	Pinion Shaft Hub Handle	1
191	6173	B191	Black Plastic Ball Handles 3/8	1
192	6101		Quill Housing	1
193	6101-1	B147	Adjust Shaft	1
194	6010-2	B154	Screw	1

8-2. 3HP Head Top Housing

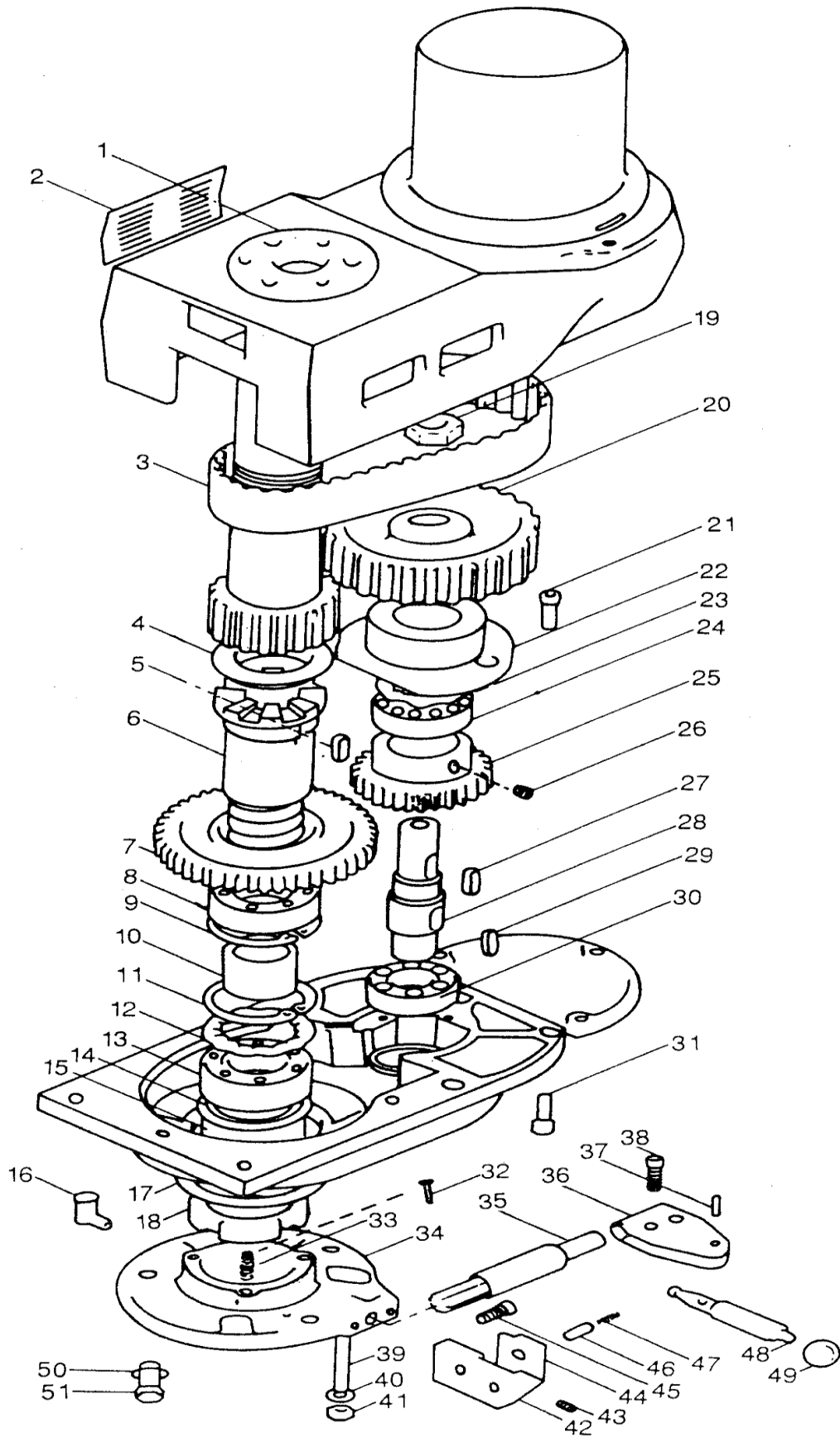

3HP Head Top Housing

ITEM NO.	PARTS NO.	FACTORY NO.	DESCRIPTION	Q'TY
1	7013	VS13	Top Bearing Cap	1
2	H7088	VS101	Ventilator	2
3	7036	VS63	Timing Belt	1
4	7038	VS100	Timing Pulley Clutch Sleeve	1
5	7081	VS72	Key--	1
6	7039	VS73	Splined Gear Hub	1
7	7040	VS74	Spindle Bull Gear	1
8	7041	VS77	Bearing-6908ZZ	1
9	7042	VS80	Snap Ring	1
10	7043	VS78	Bull Gear Bearing Spacer	1
11	7042	VS80	Snap Ring	1
12	7058	VS73-1	Wave Spring Washer	1
13	7041	VS77	Bearing-6908ZZ	1
14	7057-2	VS	Washer	1
15	7057	VS79	Bearing Sleeve Spacer	1
16	7054	VS82-1	Oil Cap	1
17	7048	VS75	Ball Bearing Gear Sleeve	1
18	7056	VS81	Bearing Lock Nut	1
19	7087	VS61	Jam Nut	1
20	7086	VS62	Timing Belt Pulley	1
21	7085	VS12	Socket HD Cap Screw	3
22	7084	VS64	Bull Gear Pinion Bearing Cap	1
23	7082	VS64-1	Wave Spring Washer	1
24	7079	VS65	Ball Bearing --6203ZZ	1
25	7083	VS66	Bull Gear Pinion	1
26	7077	VS03	Socket Set Screw--	1
27	7078	VS68	Key--	1
28	7080	VS67	Bull Gear Pinion Counter Shaft	1
29	7078	VS69	Key--	1
30	7079	VS65	Ball Bearing --6203ZZ	1
31	7073	VS51	Socket HD Cap Screw	6
32	7055-1	VS102	T-Tip Pin	3
33	7055	VS84	Compression Spring	3
34	7049	VS83	Fixed Clutch Bracket	1

3HP Head Top Housing

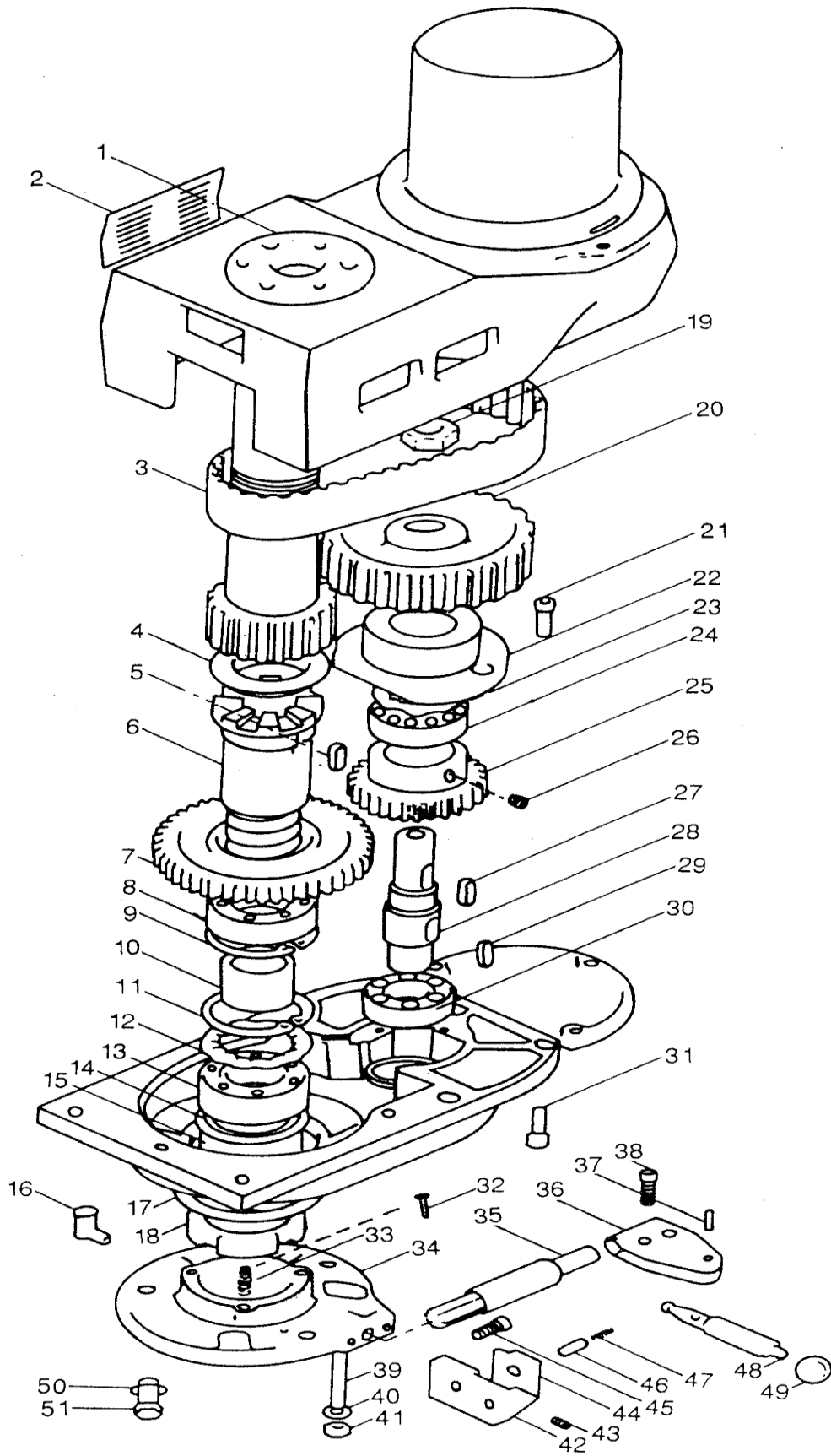

3HP Head Top Housing

ITEM NO.	PARTS NO.	FACTORY NO.	DESCRIPTION	Q'TY
35	7059	VS87	Bull Gear Shift Pinion Shaft	1
36	7071	VS92	Hi-Low Pinion Block	1
37	7072	VS88	Spring Pin	1
38	7072-1	VS92-1	Socket HD Cap Screw	2
39	7063	VS85	Stud	3
40	7062	VS85-1	Spring Washer	3
41	7061	VS85-2	Hex Nut	3
42	7060	VS89	Hi-Low Detent Plate	1
43	7064	VS	Socket Set Screw--	1
44	7065	VS89-1	Adjustable Plate	1
45	7068	VS12	Socket HD Cap Screw	2
46	7066	VS90	Hi-Low Detent Plunger	1
47	7067	VS91	Spring	1
48	7070	VS94	Hi-Low Shift Crank	1
49	7069	B24	Bakelite Ball	1
50	7045	VS86	Hex Cap Screw	3
51	7046	VS86-1	Spring Washer	3

8-3. 3HP Head Back Gear

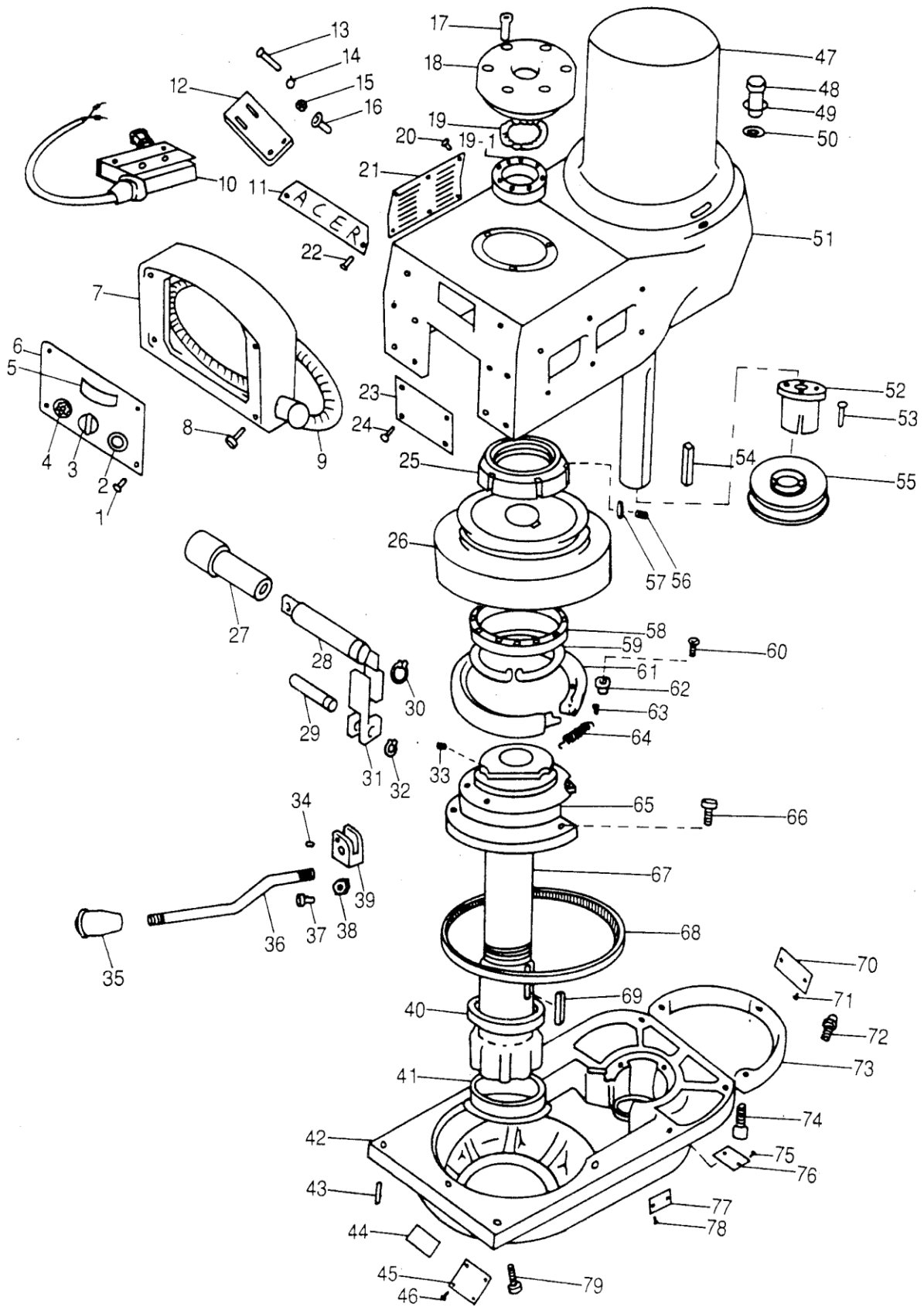

3HP Head Back Gear

ITEM NO.	PARTS NO.	FACTORY NO.	DESCRIPTION	Q'TY
1	7022-1	VS17-1	Round + Cap Screw	4
2	9500	VS	Emergency Switch	1
3	9501	VS	F/R Switch	1
4	9502	VS	Variable Resistor	1
5	9503	VS	RPM Meter-10V	1
	9503-1		RPM Meter-7.5V	1
	9503-2		RPM Digital Counter	1
6	H7023-1	VS16-5	Chromed Face Plate	1
	H7023-2		Chromed Face Plate UL	1
7	H7005-1	VS16-6	Speed Chanter Housing	1
8	H7025	VS17	Socket HD Cap Screw	4
9	9504	VS	Control Wire Cable	1
10	9505	VS	Limit Switch w/Cable	1
11	H8010-1	VS1-4	ACER Name Plate	1
12	H8010-2	VS1-5	Limit Switch Bracket Plate	1
13	7022-2	VS	Round Socket Cap Screw	2
14	7022-3	VS	Spring Washer	2
15	7022-4	VS	Hex Nut	2
16	7022-5	VS	Socket HD Cap Screw	2
17	8001	VS14	Socket HD Cap Screw	3
18	7013	VS13	Top Bearing Cap	1
19	8003	VS13-1	Wave Spring Wahser	1
19-1	8004	VS15	Ball Bearing --6007ZZ	1
20	H7088-1	VS101-1	Round Cap Wooden Screw	12
21	H7088	VS101-1	Ventilator	2
22	H8010-3	VS1-6	Round Socket Cap Screw	2
23	H8010-4	VS1-7	Covering Plate	1
24	H8010-5	VS1-8	Round HD Screw	4
25	8034-1	VS70-2	Spindle Pulley Hub Lock-Nut	1
26	8028-1	VS45-1	Stationary Driven Pulley	1
27	H8073	VS52	Sleeve for Brake Lock Shaft	1
28	H8074	VS53	Brake Lock Shaft	1
29	8068	VS58	Brake Finger Pivot Stud	1
30	8068-1	VS60-1	Snap Ring	1

3HP Head Back Gear

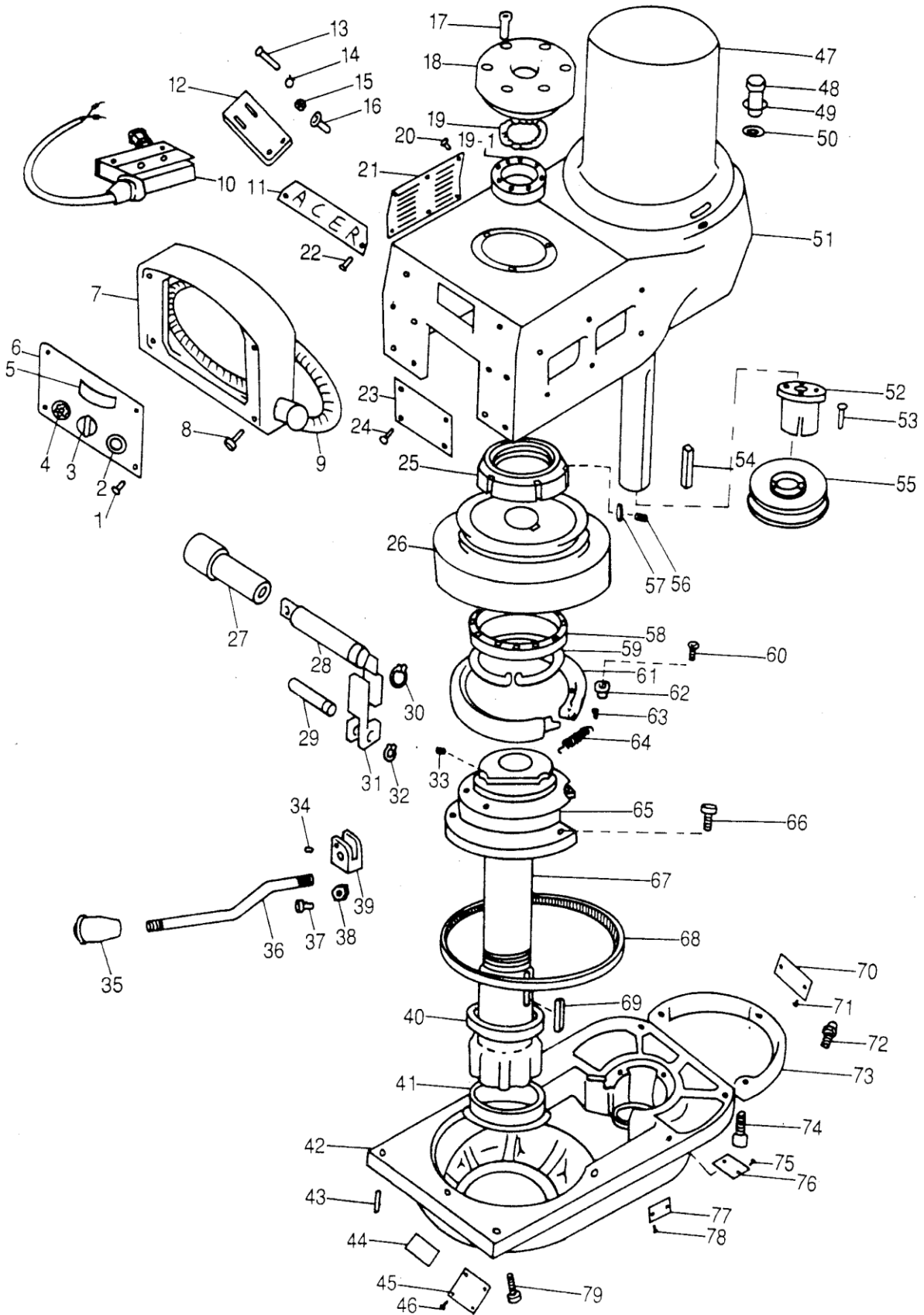

3HP Head Back Gear

ITEM NO.	PARTS NO.	FACTORY NO.	DESCRIPTION	Q'TY
31	8067	VS59	Brake Operating Finger	2
32	8066	VS60	Snap Ring	1
33	H8077	VS99	Socket Set Screw	2
34	8072	VS54-1	Socket Set Screw	1
35	8069	VS57	Bakelite Ball Handle	1
36	8070	VS56	Brake Lock Handle	1
37	8071-1	VS55-1	Socket HD Cap Screw	1
38	8070-1	VS56-1	Hex Nut	1
39	8070-2	VS54	Brake Handle Block	1
40	8033	VS98	Spindle Pulley Spacer	1
41	7038	VS100	Timing Pulley Clutch Sleeve	1
42	H8063	VS82	Gear Housing	1
43	8060	VS82-1	Taper Pin	1
44	H8063-1	VS82-3	Oil Add Name Plate	1
45	8061	VS82-1	Quill Feed Name Plate	1
46	8059	VS	Drive Screw	4
47	8008-1	VS	3HP Spindle Motor	1
48	8009	VS	Socket HD Cap Screw	2
49	8009-1	VS	Spring Washer	2
50	8009-2	VS	Washer	1
51	H8010	VS01	Belt Housing	1
52	8040-2	VS02-2	V-Belt Pulley Sleeve	1
53	8040-3	VS02-3	Hex HD Scrw	2
54	8039	VS06	Key	1
55	8040-1	VS02-1	V-Belt Pulley	1
56	8034-2	VS70-3	Socket Set Screw	2
57	8034-3	VS70-4	Round Copper Tip	2
58	8023	VS43	Ball Bearing-6010ZZ	1
59	H8053-1	VS50-1	Snap Ring	1
60	8035	VS14	Round Socket Cap Screw	1
61	8032	VS47	Brake Shoe Assembly	1
62	8036	VS48	Brake Shoe Pivot Sleeve	1
63	8032-1	VS47-1	Round Cap Screw	4
64	8031	VS49	Brake Spring	2

3HP Head Back Gear

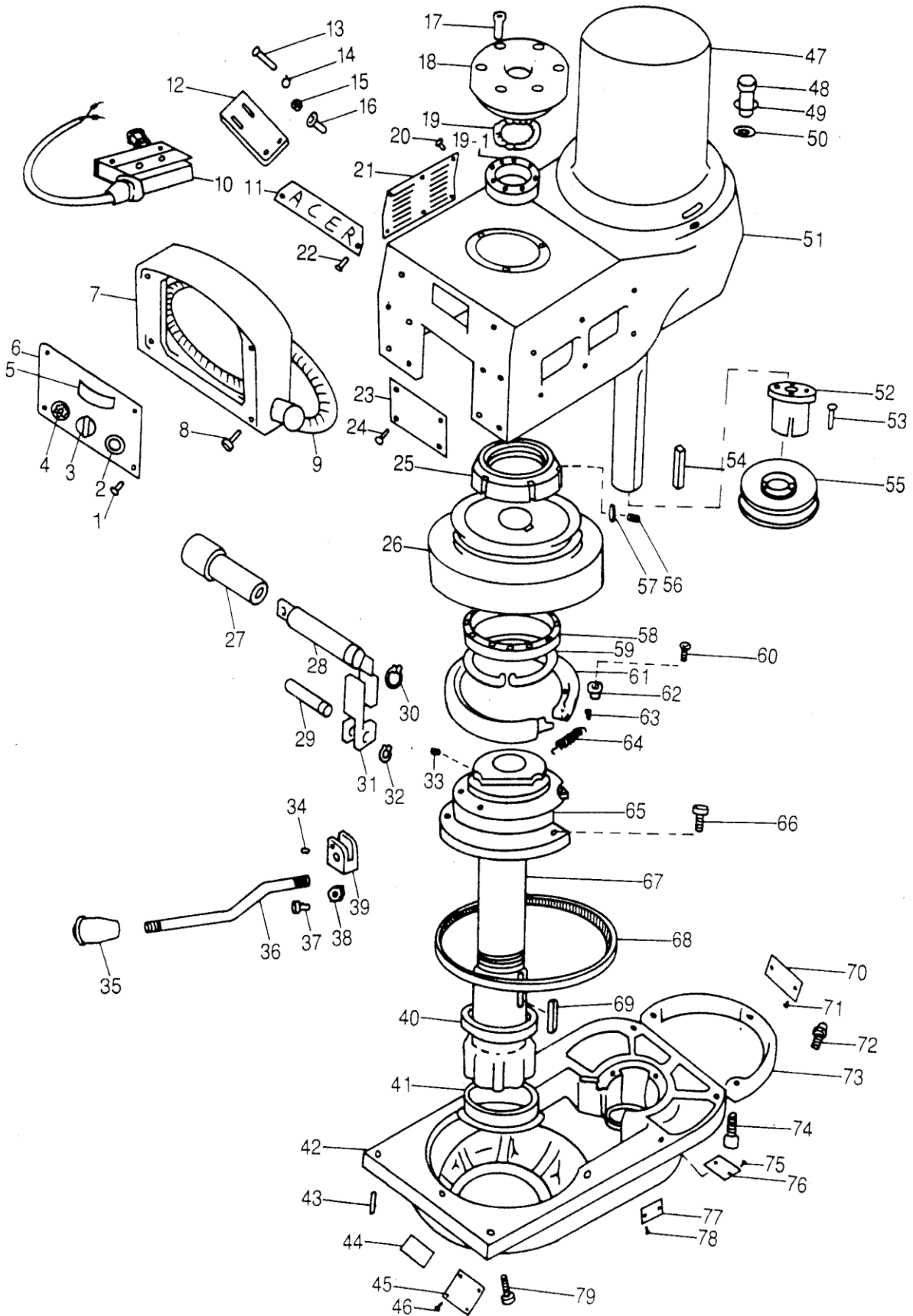

3HP Head Back Gear

ITEM NO.	PARTS NO.	FACTORY NO.	DESCRIPTION	Q'TY
65	H8053-2	VS50-2	Belt Housing Base	1
66	H8064	VS51	Socket HD Cap Screw	3
67	8034-5	VS70-1	Spindle Pulley Hub	1
68	8027-1	VS04-1	V Belt	1
69	8049-1	VS71-1	Key	1
70	8063-2	VS07-1	Grease Add Name Plate	1
71	8059	VS	Drive Screw	2
72	8063-3	VS82-4	Grease Nibble	1
73	8054	Vs11	Motor Pulley Cover	1
74	8055	VS12	Socket HD Cap Screw	3
75	8063-2	VS01-1	Grease Add Name Plate	1
76	8059	VS	Drive Screw	2
77	8058	VS82-2	Hi-Low Range Name Plate	1
78	8059	VS	Drive Screw	2

8-4. 5HP (MILLING HEAD) HAND FEED ASS'Y

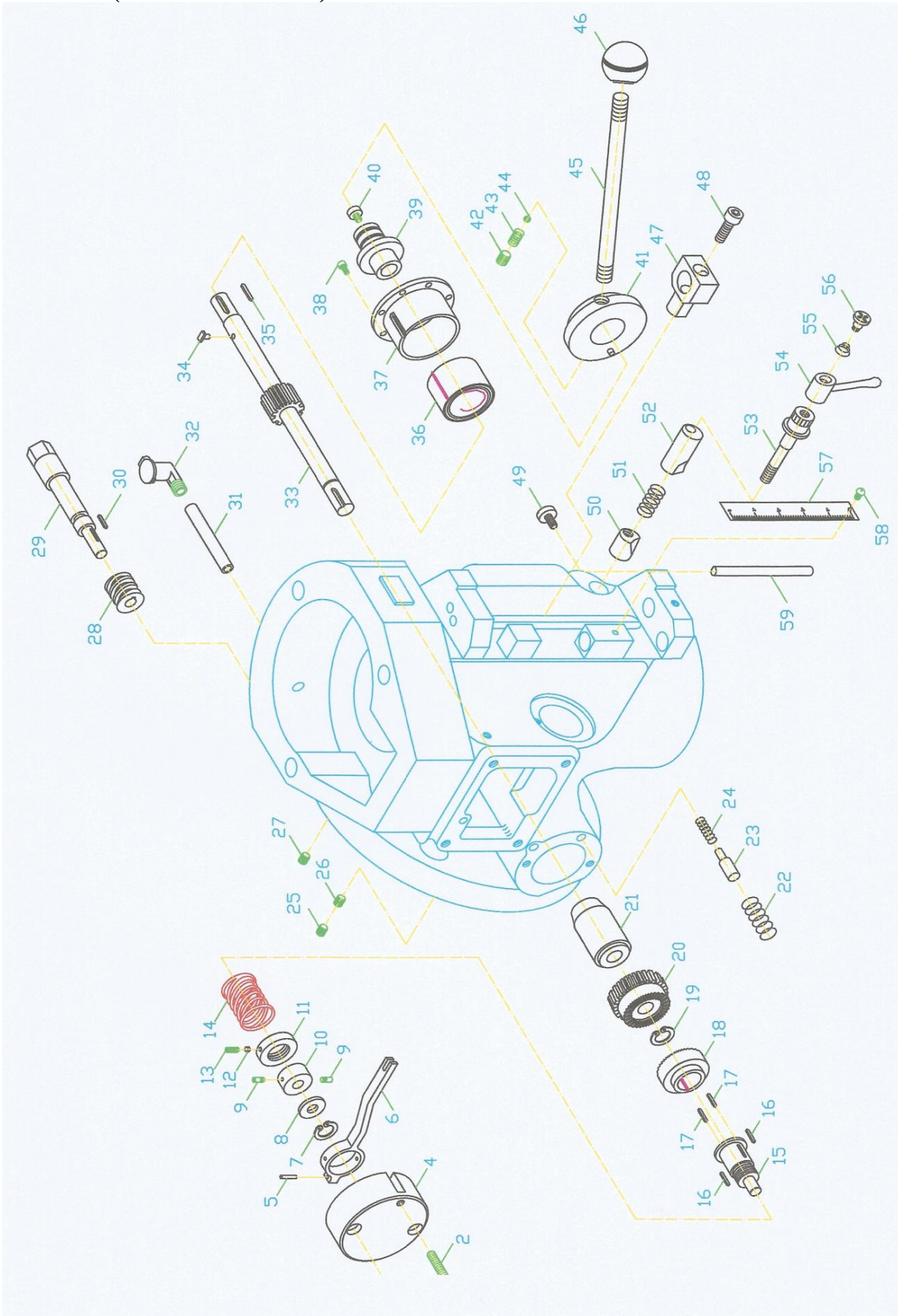

5HP (MILLING HEAD) HAND FEED ASS'Y

ITEM NO.	PARTS NO.	FACTORY NO.	DESCRIPTION	Q'TY
1	5K-6208	M6	Hex Nut	1
2	5K-6207	M6x16	Socket Set Screw	1
3	5K-6206	M5x35	Socket HD Cap Screw	2
4	5K-6205	B99	Clutch Arm Cover	1
5	5K-6204	5x20	Roll Pin	1
6	5K-6203	FB96	Overload Clutch Trip Lever	1
7	5K-6195-1	C10	Snap Ring	1
8	5K-6201	B97	Overload Clutch Washer	1
9	5K-6202	B74	Clutch Ring Pin	2
10	5K-6200	B75	Clutch Ring	1
11	5K-6198	B78	Overload Clutch Lock nut	1
12	5K-6199-1		Brass Plug	1
13	5K-6199	M6x6	Socket Set Screw	1
14	5K-6197	FB79	Safety Clutch Spring	1
15	5K-6195	FB81	Overload Clutch Sleeve	1
16	5K-6196	5x20	Key	2
17	5K-6196	5x25	Key	2
18	5K-6194	FB80	Overload Clutch	1
19	5K-6188-1	C16	Snap Ring	1
20	5K-6187+88	FB92+93	Overload Clutch Worm Gear and Ring	1
21	5K-6186	FB90+91	Quill Pinion Shaft Bushing	1
22	5K-6192	B88-1	Compression Spring	1
23	5K-6193	B89	Overload Clutch Lever Spring Plunger	1
24	5K-6191	FB88	Compression Spring	1
25	5K-6246-1	M6x6	Socket Set Screw	1
26	5K-6246	M6x16	Lock Screw	1
27	5K-5042		Set Screw Plunger	1
28	5K-5039	B186	Worm Gear	1
29	5K-5040	FB189	ADJ Worm Shaft	1
30	5K-5041	4x20	Key	1
31	5K-6133-1		Bronze Tubing	1
32	5K-6133		Oil Cup	1
33	5K-6172	FB166	Quill Pinion Shaft	1
34	5K-6172-1	B168	Cap Tip- T shape	1
35	5K-6184	3x20	Key	1
36	5K-6181	FB178	Clock Spring	1

5HP (MILLING HEAD) HAND FEED ASS'Y

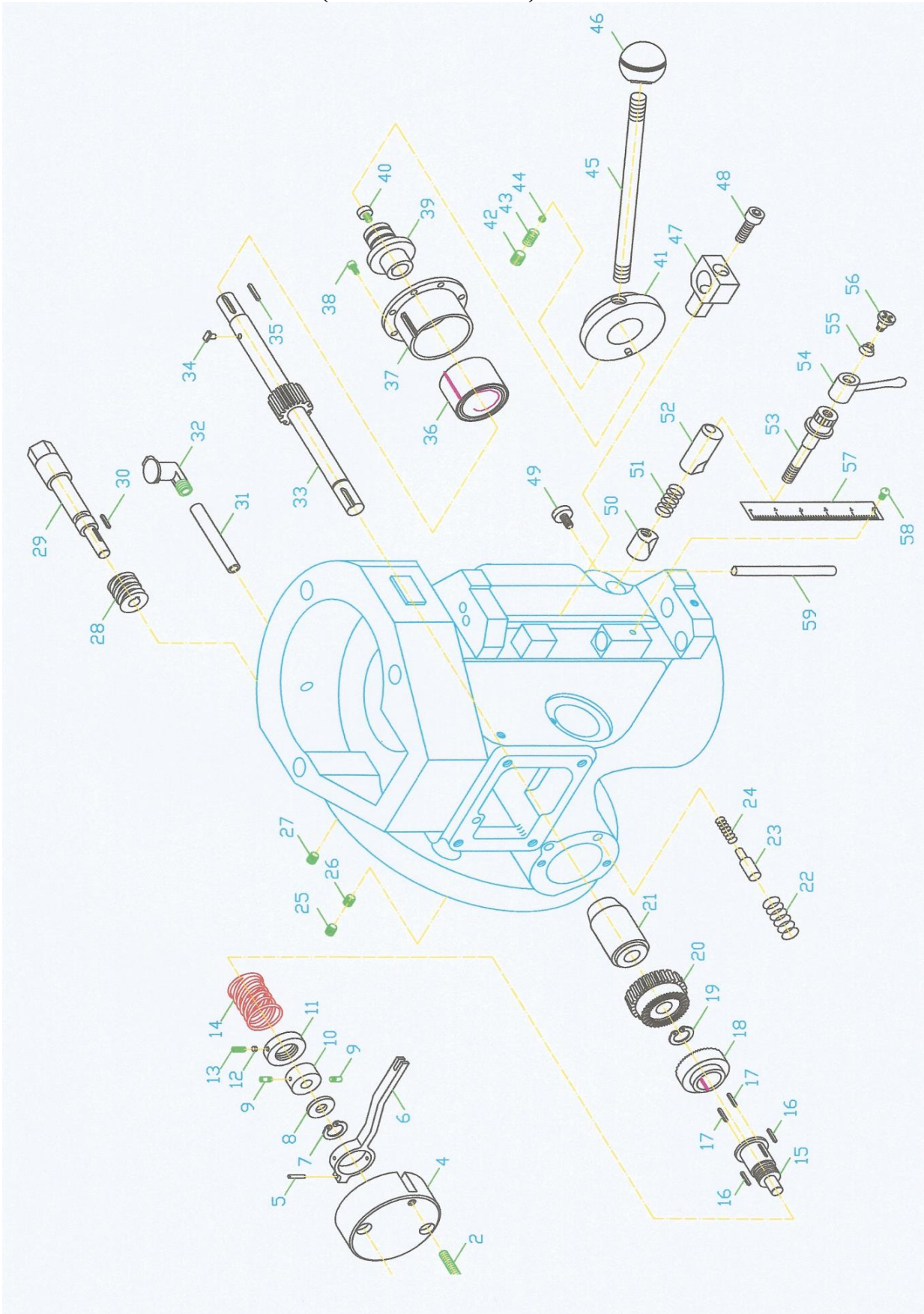

5HP (MILLING HEAD) HAND FEED ASS'Y

ITEM NO.	PARTS NO.	FACTORY NO.	DESCRIPTION	Q'TY
37	5K-6180	FB177	Spring Cover	1
38	5K-6180-1	M5x12	Socket HD Cap Screw	2
39	5K-6182	B176	Pinion Shaft Hub Sleeve	1
40	5K-6183	B172	Pinion Shaft Hub Screw	1
41	5K-6178	B175	Rack Feed Handle Hub	1
42	5K-6177	M8x6	Socket Set Screw	1
43	5K-6175		Compression Spring	1
44	5K-6176		Steel Ball	1
45	5K-6174	B190	Pinion Shaft Hub Handle	1
46	5K-6173	B191	Black Plastic Ball	1
47	5K-6105	FB164	Quill Stop Knob	1
48	5K-6106	3/8x5/8x24T	Socket HD Cap Screw	1
49	5K-6253	B154	Cap Screw	1
50	5K-6116B	B148	Quill Lock Sleeve Tapped	1
51	5K-6116-1	B152-1	Compression Spring	1
52	5K-6116A	FB153	Quill Lock Sleeve	1
53	5K-6117	FB152	Quill Lock Bolt	1
54	5K-6119	FB149	Lock Handle	1
55	5K-6117-1		Spring	1
56	5K-6117-2		Spring Screw	1
57	5K-6243	B159	Micrometer Scale	1
58	5K-6244	M4x8	Round HD Cap Screw	2
59	5K-6251	B147	Set Bar	1

8-5. 5HP (MILLING HEAD) SPINDLE ASS'Y

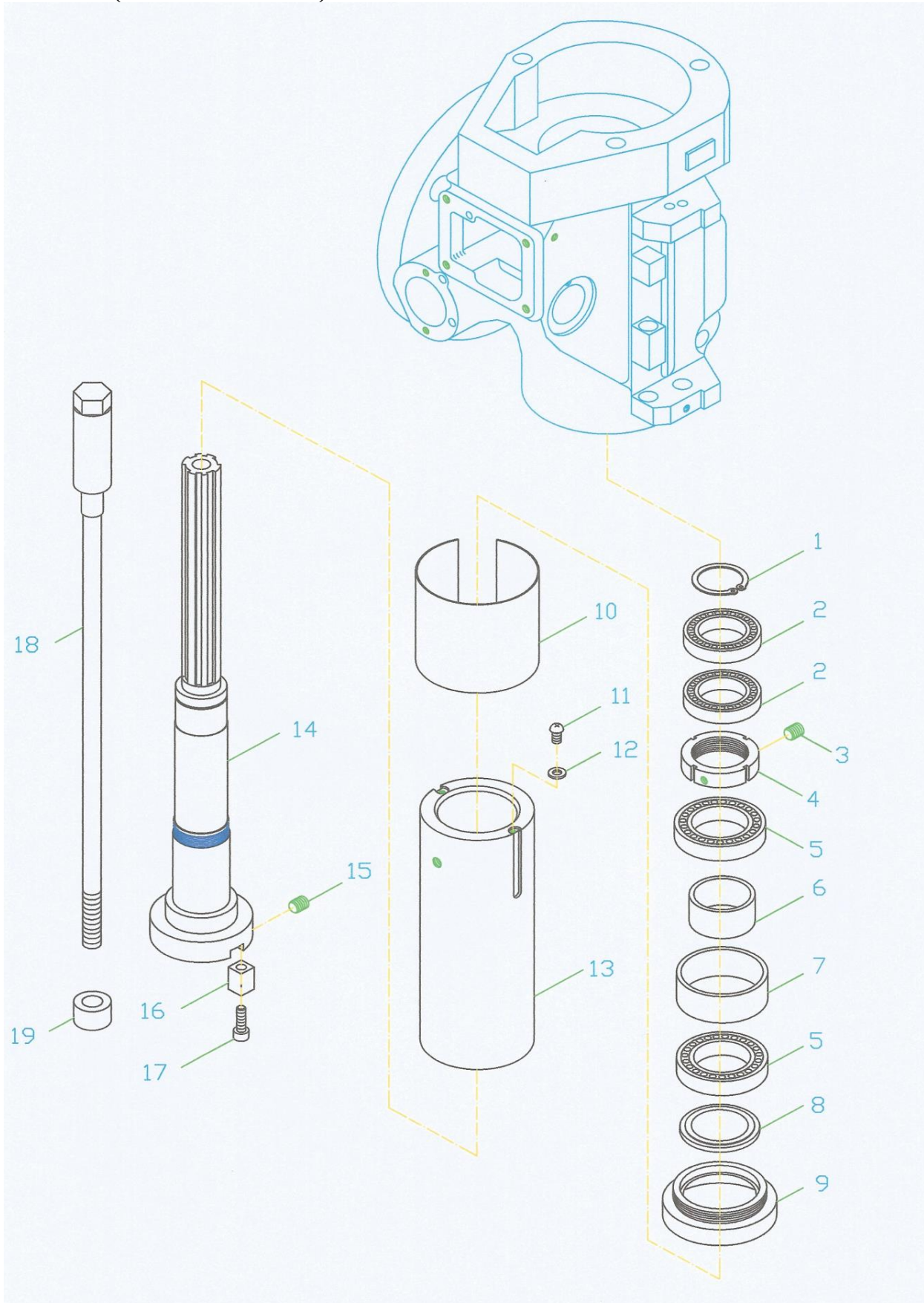

5HP (MILLING HEAD) SPINDLE ASS'Y

ITEM NO.	PARTS NO.	FACTORY NO.	DESCRIPTION	Q'TY
1	5K-6090	C40	Snap Ring	1
2	5K-6092		Ball Bearing- 6008LLB	2
3	5K-6094-1	M8x6	Socket Set Screw	2
4	5K-6094	FB129	Lock Nut	1
5	5K-6093		Ball Bearing- 7010	2
6	5K-6096	FB137	Bearing Spacer- Small	1
7	5K-6095	FB136	Bearing Spacer- Large	1
8	5K-6097	FB134	Spindle Dirt Shield	1
9	5K-6098	FB133	Nose Piece	1
10	5K-6086	FB128	Quill Skirt	1
11	5K-6088-1	M5x8	Felt Washer Screw	2
12	5K-6088-2	M5	Washer	2
13	5K-6085	FB142	Quill	1
14	5K-6084	FB127	Spindle #40	1
15	5K-6085-1	M5x8	Socket Set Screw	1
16	5K-6099	FB127-1	Keeper Key	2
17	5K-6100	M8x25	Socket HD Cap Screw	2
18	5K-8014		Drawbar	1
19	5K-8020		Drawbar Washer	1

8-6. 5HP (MILLING HEAD) AUTO FEED ASS'Y

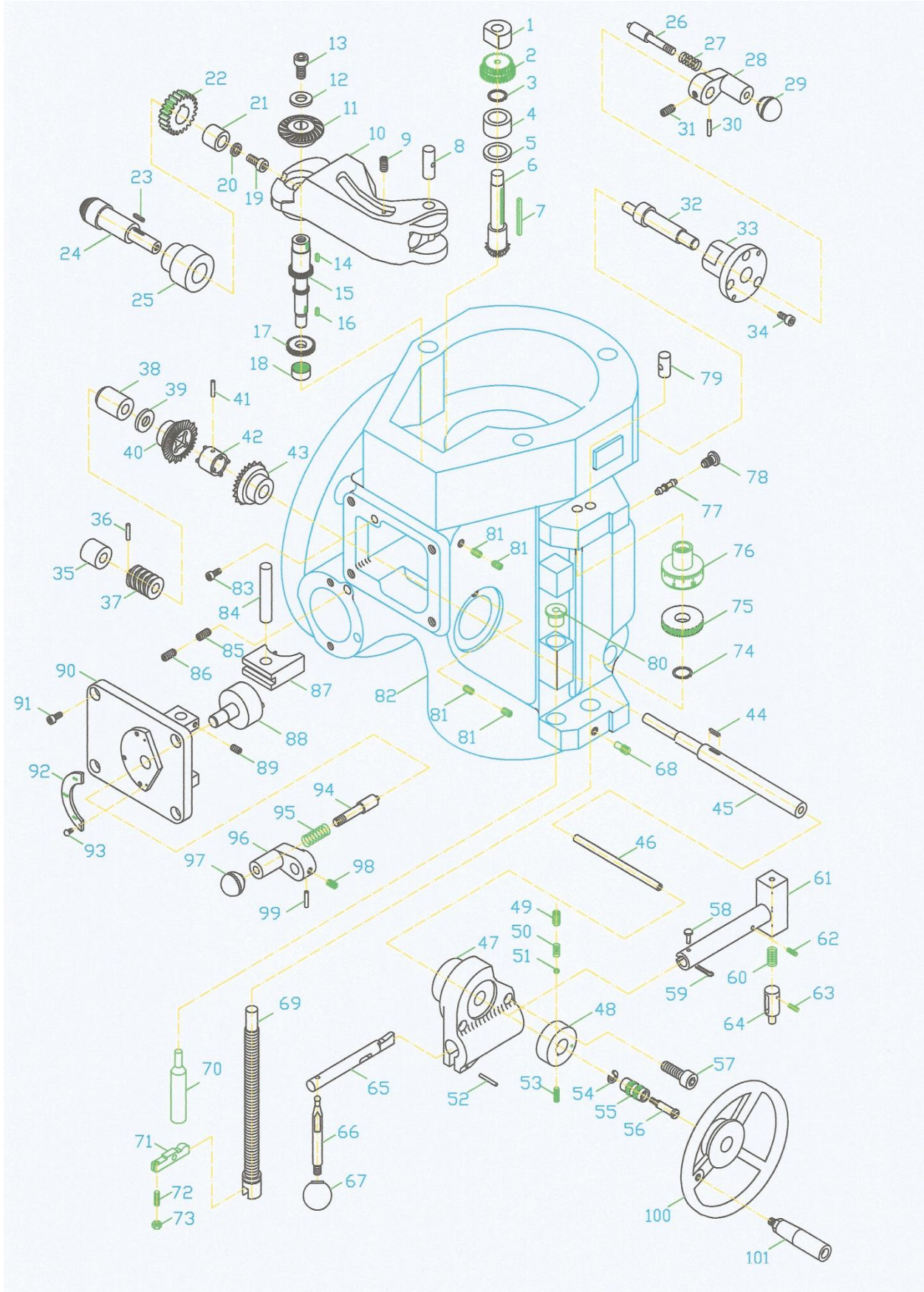

5HP (MILLING HEAD) AUTO FEED ASS'Y

ITEM NO.	PARTS NO.	FACTORY NO.	DESCRIPTION	Q'TY
1	5K-6157	B27	Cluster Gear Shaft Upper Bearing	1
2	5K-6153	FB28	Cluster Gear Assembly	1
3	5K-6158	C16	Snap Ring	1
4	5K-6156	FB33	Bevel Gear Bearing	1
5	5K-6159	FB34	Bevel Gear Thrust Spacer	1
6	5K-6151	FB31+35	Cluster Gear Shaft	1
7	5K-6160	M3x35	Cluster Gear Key	1
8	5K-6122	B16	Feed Engage Pin	1
9	5K-6123	M6x6	Socket Set Screw	1
10	5K-6121	FB17	Worm Gear Cradle	1
11	5K-6148	FB15	Feed Reverse Bevel Gear	1
12	5K-6149	FB13, 3/8"	Washer	1
13	5K-6150	3/8x1/4	Socket HD Cap Screw	1
14	5K-6147	3x8	Key	1
15	5K-6143	FB36	Feed Driving Gear Shaft	1
16	5K-6145	3x10	Key	1
17	5K-6144	FB40	Feed Drive Gear	1
18	5K-6252	BA66	Needle Bearing	1
19	5K-6124	M6x12	Socket HD Cap Screw	1
20	5K-6140	M6	Washer	1
21	5K-6136-1		Worm Gear Bushing	1
22	5K-6134		Feed Drive Worm Gear	1
23	5K-6135	3x12	Key	1
24	5K-6139		Feed Bevel Pinion	1
25	5K-6136+37		Worm Gear Cradle Bushing	1
26	5K-6169	B20	Gear Shift Plunger	1
27	5K-6170	B21	Compression Spring	1
28	5K-6168	B23	Shift Crank	1
29	5K-6131	B24	Black Plastic Ball	1
30	5K-6128	3x20	Spring Pin	1
31	5K-6168-1	M5x5	Socket Set Screw	1
32	5K-6126	B18	Worm Gear Cradle Throw-out	1
33	5K-6125	B19	Shift Sleeve	1
34	5K-6132	M5x12	Socket HD Cap Screw	3
35	5K-6227	B42	Bushing	1
36	5K-6226	3x10	Spring Pin	1

5HP (MILLING HEAD) AUTO FEED ASS'Y

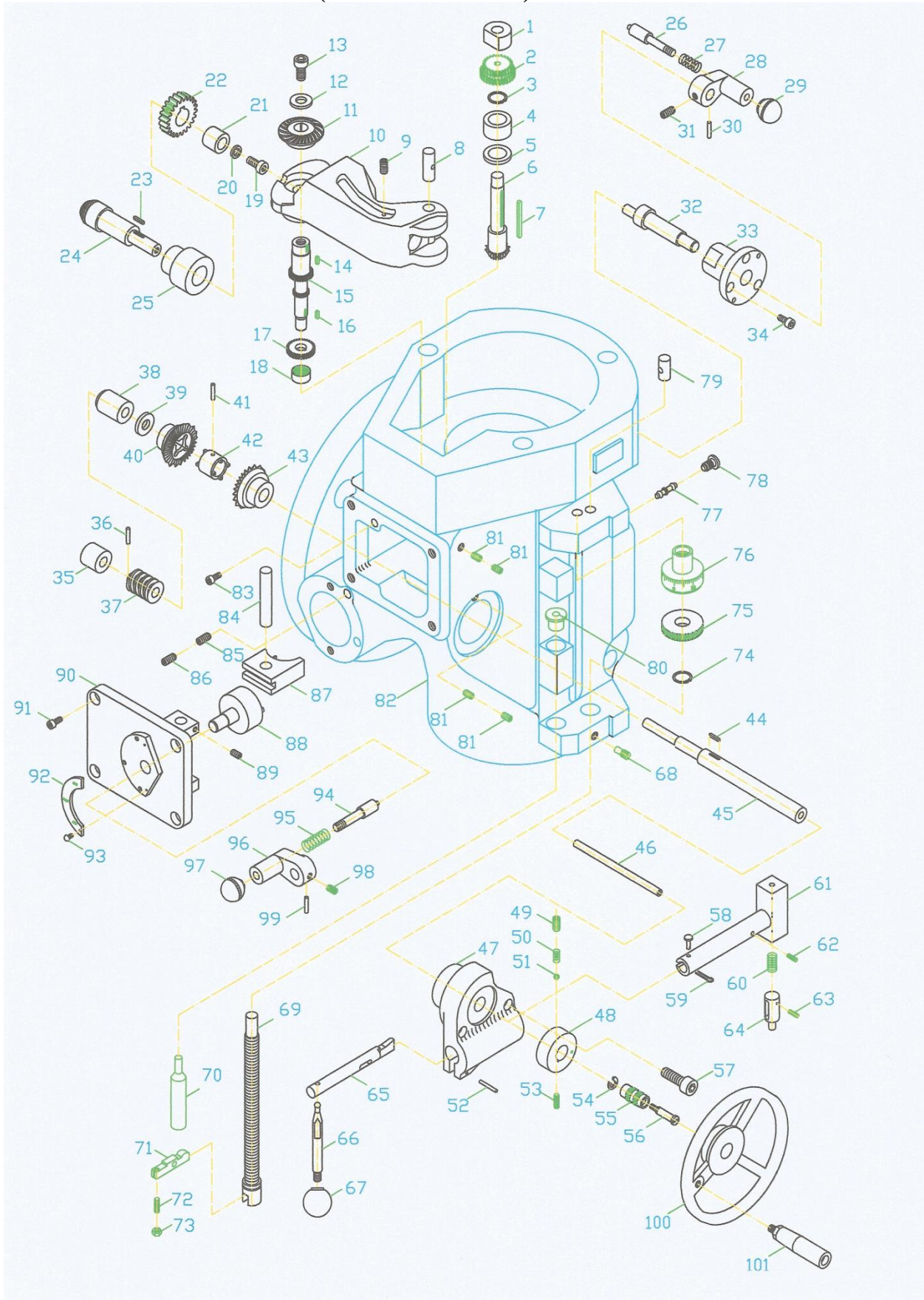

5HP (MILLING HEAD) AUTO FEED ASS'Y

ITEM NO.	PARTS NO.	FACTORY NO.	DESCRIPTION	Q'TY
37	5K-6225	B43	Worm	1
38	5K-6224	FB44	Feed Worm Shaft Bushing	1
39	5K-6223	B47	Feed Worm Shaft Thrust Washer	1
40	5K-6220	B48+49	Feed Reverse Bevel Gear	1
41	5K-6217	3x20	Spring Pin	1
42	5K-6222	B50	Feed Reverse Clutch	1
43	5K-6220	B48+49	Feed Reverse Bevel Gear	1
44	5K-6230	3x15	Key	1
45	5K-6209	FB57	Feed Worm Shaft	1
46	5K-6216	FB55	Reverse Clutch Rod	1
47	5K-6231	FB106	Feed Trip Bracket	1
48	5K-6218	B113	Handwheel Clutch	1
49	5K-6219-1	M8x6	Socket Set Screw	1
50	5K-6219-2	B115	Compression Spring	1
51	5K-6255	B114	Steel Ball	1
52	5K-6231-1	5x20	Dowel Pin	1
53	5K-6219	M6x6	Socket Set Screw	1
54	5K-6215	B112, E5	Snap Ring	1
55	5K-6213	B111	Reverse Knob	1
56	5K-6214	B110	Feed Reverse Knob Stud	1
57	5K-6232	M6x25	Socket HD Cap Screw	2
58	5K-6236-1		Dowel Pin	1
59	5K-6241-1	#2	Y Pin	1
60	5K-6242	B120	Compression Spring	1
61	5K-6236	FB118	Cam Rod Sleeve Assembly	1
62	5K-6237	3x16	Spring Pin	1
63	5K-6241	3x12	Spring Pin	1
64	5K-6240	B121	Trip Plunger	1
65	5K-6239	FB103	Cam Rod	1
66	5K-6234	FB104	Trip Handle	1
67	5K-6131	B24	Black Plastic Ball	1
68	5K-6112		Trip Lever Pin	1
69	5K-6104	B164	Quill Stop Micro-Screw	1
70	5K-6118	B124	Feed Trip Plunger	1
71	5K-6111	B145	Feed Trip Lever	1
72	5K-6113	B146, M4x20	Socket Set Screw	1
73	5K-6113-1	M4	Hex Nut	1
74	5K-6115	C16	Snap Ring	1

5HP (MILLING HEAD) AUTO FEED ASS'Y

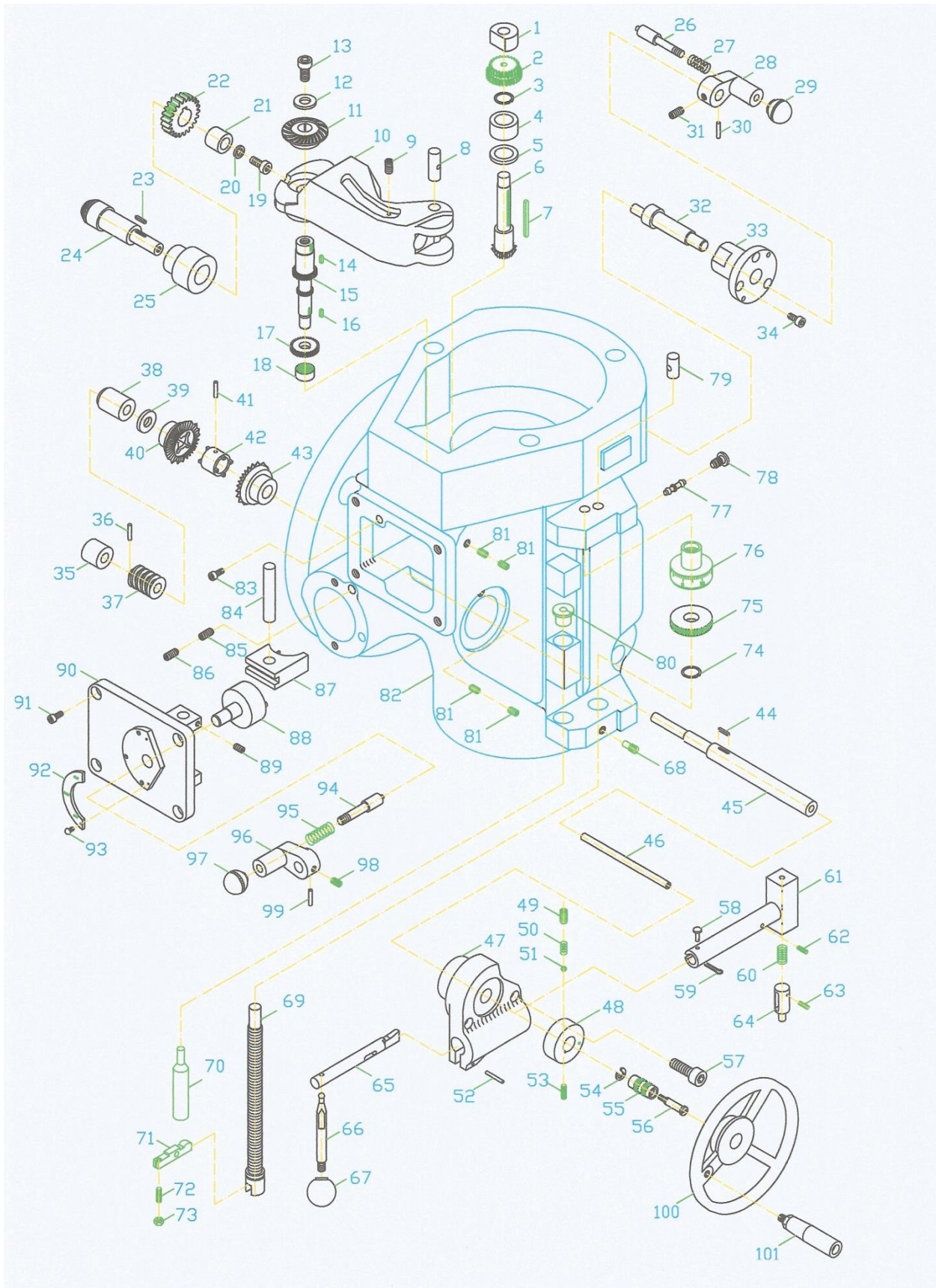

5HP (MILLING HEAD) AUTO FEED ASS'Y

ITEM NO.	PARTS NO.	FACTORY NO.	DESCRIPTION	Q'TY
75	5K-6108	B161	Quill Micro-Stop Nut	1
76	5K-6107	B162	Micrometer Nut	1
77	5K-6110	B183	Reverse Trip Ball Lever	1
78	5K-6114	B185	Reverse Trip Ball Lever Screw	1
79	5K-6109	B184	Feed Reverse Trip Plunger	1
80	5K-6118-1	B123	Trip Plunger Bushing	1
81	5K-6246	M6x8	Socket Set Screw	4
82	5K-6101	FB192	Quill Housing	1
83	5K-6101-1	M6x30	Socket HD Cap Screw	1
84	5K-6163	B60	Feed Shift Rod	1
85	5K-6228	M6x12	Mock-It Lock Screw	1
86	5K-6228-1	M6x8	Socket Set Screw	1
87	5K-6162	B63	Feed Gear Shift Fork	1
88	5K-6166	FB64	Cluster Gear Shift Crank	1
89	5K-6164	M5x5	Socket Set Screw	1
90	5K-6161	FB66	Cluster Gear Cover	1
91	5K-6165	M5x12	Socket HD Cap Screw	4
92	5K-6165-1	VS66-1	Feed Rate Plate	1
93	5K-6165-2		Drive Screw	2
94	5K-6169	B20	Gear Shift Plunger	1
95	5K-6170	B21	Compression Spring	1
96	5K-6168	B23	Shift Crank	1
97	5K-6171	B24	Black Plastic Ball	1
98	5K-6168-1	M5x5	Socket Set Screw	1
99	5K-6167	3x20	Spring Pin	1
100	5K-6210	B125	Handwheel	1
101	5K-6210-1	B126	Handle	1

8-7. 5HP E-mill HEAD TOP HOUSING

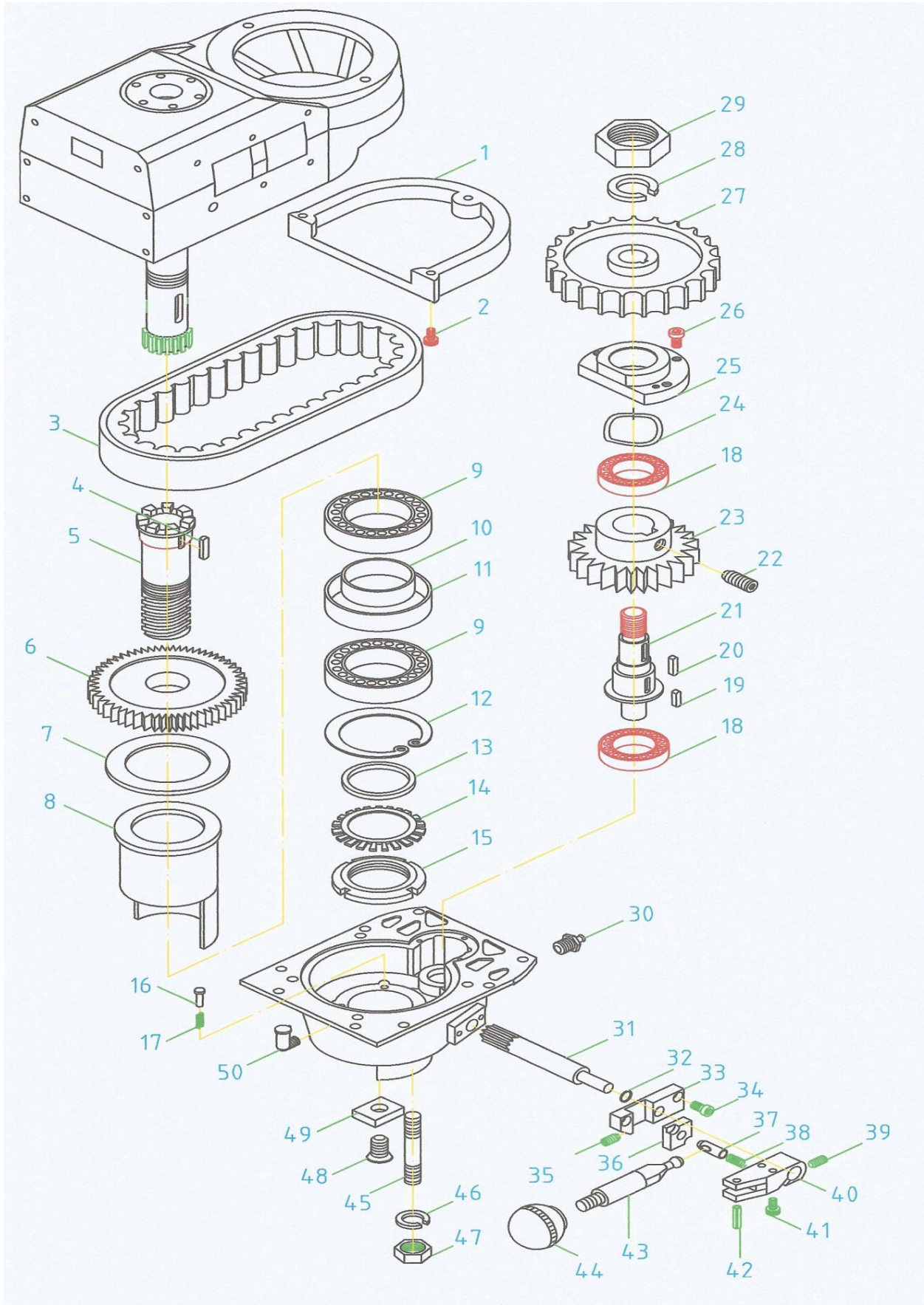

5HP E-mill HEAD TOP HOUSING

ITEM NO.	PARTS NO.	FACTORY NO.	DESCRIPTION	Q'TY
1	8054	VS11	Motor Pulley Cover	1
2	8055	VS12	Socket HD Cap Screw	3
3	5E7036	FVS63	Timing Belt	1
4	5E7081	FVS72	Key	1
5	5E7039	FVS73	Splined Gear Hub	1
6	5E7040	FVS74	Spindle Bull Gear	1
7	5E7057-2	FVS100	Bull Gear Washer	1
8	5E7048	FVS75	Ball Bearing Gear Sleeve	1
9	5E7041	FVS77	Bearing—6910VV	2
10	5E7043	FVS78	Bull Gear Bearing Spacer	1
11	5E7057	FVS79	Bearing Sleeve Spacer	1
12	5E7042	FVS80	Snap Ring	1
13	5E7039-1	FVS	Gear Hub Spacer	1
14	5E7058	FVS73-1	Wave Spring Washer	1
15	5E7056	FVS81	Bearing Lock Nut	1
16	7055-1	VS102	T-Tip Pin	3
17	7055	VS84	Compression Spring	3
18	7079	VS65	Ball Bearing-6203ZZ	2
19	7078	VS69	Key	1
20	7078	VS69	Key	1
21	7080	VS67	Bull Gear Pinion Counter Shaft	1
22	7077	VS03	Socket Set Screw	1
23	7083	VS66	Bull Gear Pinion	1
24	7082	VS64-1	Wave Spring Washer	1
25	7084	VS64	Bull Gear Pinion Bearing Cap	1
26	7085	VS12	Socket HD Cap Screw	3
27	5E7086	FVS62	Timing Belt Pulley	1
28	5E7087-1	FVS	Spring Washer	1
29	7087	VS61	Jam Nut	1
30	8063-3	VS82-4	Grease Nibble	1
31	5E7059	FVS87	Bull Gear Shrift Pinion Shaft	1
32	5E7059-1	VS	Wave Spring Washer	1
33	7060	VS89	Hi-Low Detent Plate	1
34	7068	VS12	Socket HD Cap Screw	2
35	7064	VS	Socket Set Screw	1
36	7065	VS89-1	Adjustable Plate	1

5HP E-mill HEAD TOP HOUSING

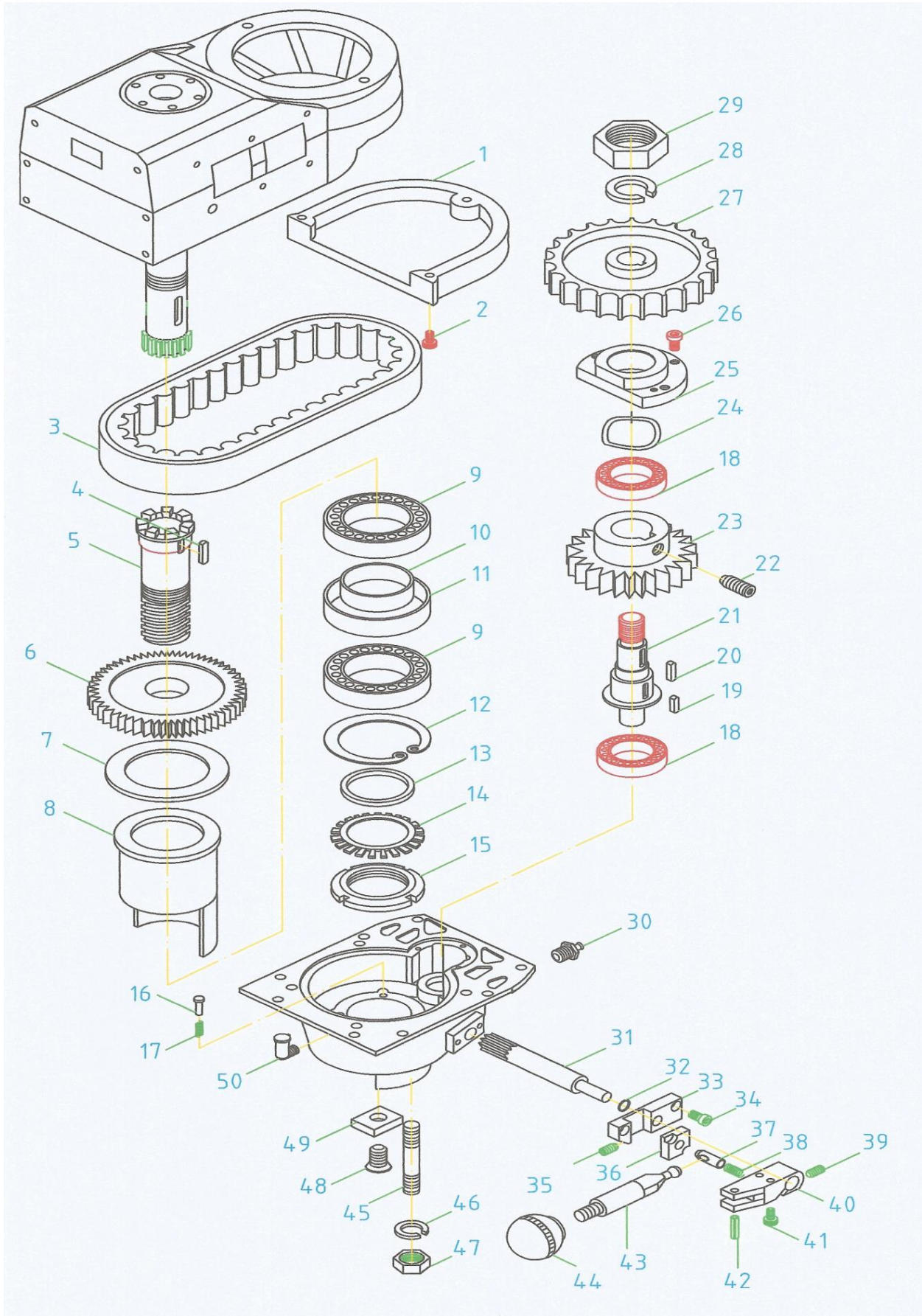

5HP E-mill HEAD TOP HOUSING

ITEM NO.	PARTS NO.	FACTORY NO.	DESCRIPTION	Q'TY
37	7066	VS90	Hi-Low Detent Plunger	1
38	7067	VS91	Spring	1
39	5E7071-1	VS	Socket Set Screw	1
40	7071	VS92	Hi-Low Pinion Block	1
41	7072-1	VS92-1	Socket HD Cap Screw	2
42	7072	VS88	Spring Pin	1
43	7070	VS94	Hi-Low Shift Crank	1
44	7069	B24	Bakelite Ball	1
45	5E7063	FVS85	Stud	3
46	5E7062	FVS85-1	Spring Washer	3
47	5E7061	FVS85-2	Hex Nut	3
48	5E7049-1	FVS83-1	Flat HD Cap Screw	2
49	5E7049-2	FVS83-2	Brass Locating Plate	2
50	7054	VS82-1	Oil Cup	1

8-8. 5HP E-mill HEAD BACK GEAR

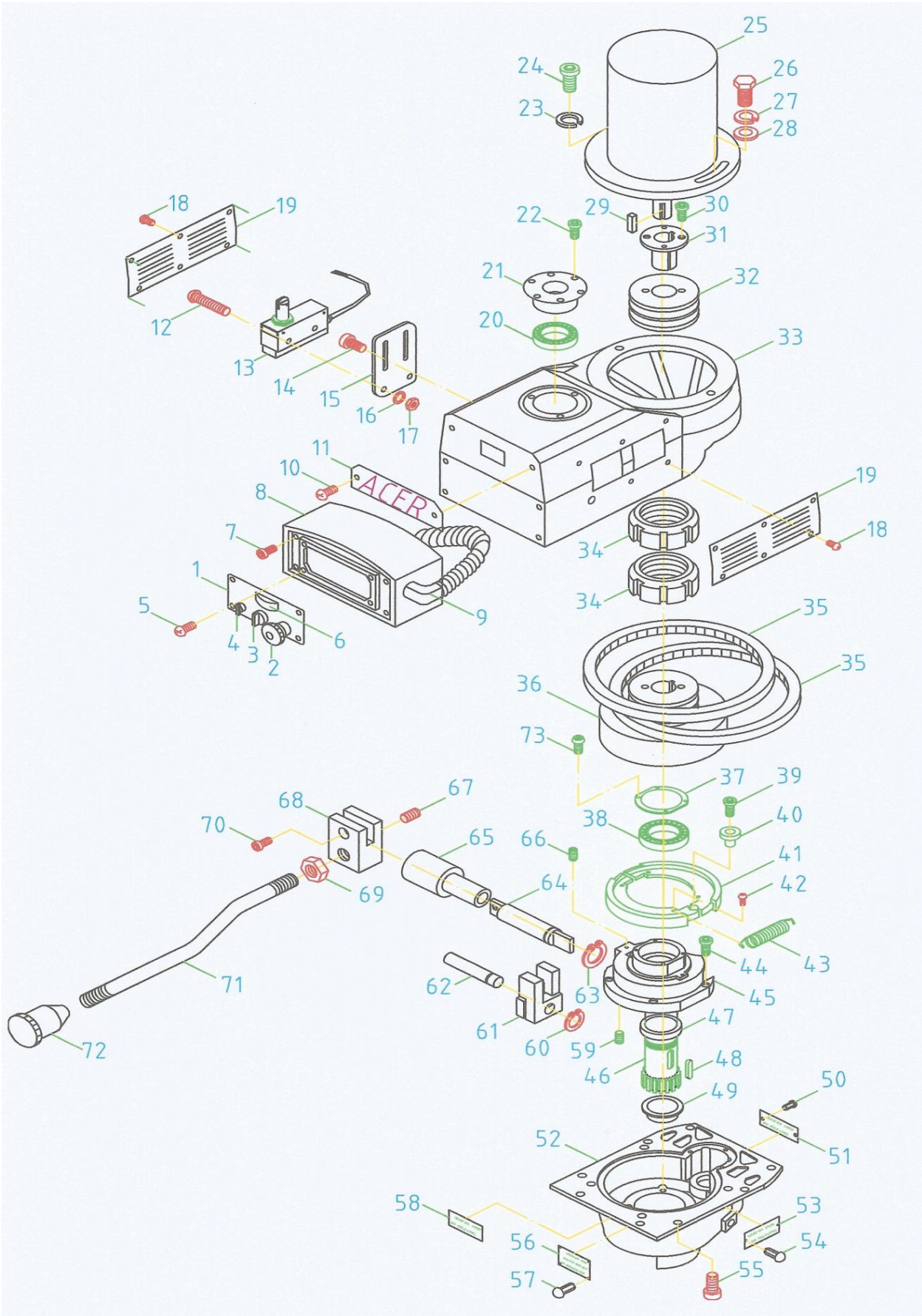

5HP E-mill HEAD BACK GEAR

ITEM NO.	PARTS NO.	FACTORY NO.	DESCRIPTION	Q'TY
1	5EH7023-1	FVS16-5	Chrome Face Plate	1
2	9500	VS	Emergency Switch	1
3	9501	VS	F/R Switch	1
4	9502	VS	Variable Resistor	1
5	7022-1	VS17-1	Round Socket Cap Screw	4
6	5E9503	VS	RPM Meter	1
7	H7025	VS17	Socket HD Cap Screw	4
8	H7005-1	VS16-6	Speed Changer Housing	1
9	9504	VS	Control Wire Cable	1
10	H8010-3	VS1-6	Round Socket Cap Screw	2
11	H8010-1	VS1-4	ACER Name Plate	1
12	7022-2	VS	Round Socket Cap Screw	2
13	9505	VS	Limit Switch w/Cable	1
14	7022-5	VS	Socket HD Cap Screw	2
15	H8010-2	VS1-5	Limit Switch Bracket Plate	1
16	7022-3	VS	Spring Washer	2
17	7022-4	VS	Hex Nut	2
18	H7088-1	VS101-1	Round Cap Wooden Screw	12
19	H7088	VS101	Ventilator	2
20	5E8004	FVS15	Ball Bearing—6209ZZ	1
21	5E7013	FVS13	Top Bearing Cap	1
22	8001	VS14	Socket HD Cap Screw	3
23	8009-3	VS	Wave Lock Washer	1
24	8009	VS	Socket HD Cap Screw	1
25	5E8008-1	VS	5 HP Spindle Motor	1
26	8009	VS	Socket HD Cap Screw	1
27	8009-3	VS	Wave Lock Washer	1
28	8009-2	VS	Washer	1
29	8039-1	VS06-1	Key	1
30	8040-3	VS02-3	Hex HD Screw	2
31	8040-2	VS02-2	V-Belt Pulley Sleeve	1
32	5E8040-1	FVS02-1	3V Belt Pulley	1
33	5E8010	FVS01	Belt Housing	1
34	5E8034-1	FVS70-2	Spindle Hub Lock Nut	2
35	5E8027-1	FVS04-1	3V Belt	2
36	5E8028-1	FVS45-1	Stationary Driven Pulley	1
37	5EH8053-3	FVS50-3	Brake Shoe Lock Plate	1
38	5E8023	FVS43	Ball Bearing—6013VV	1
39	8035	VS14	Round Socket Cap Screw	1

5HP E-mill HEAD BACK GEAR

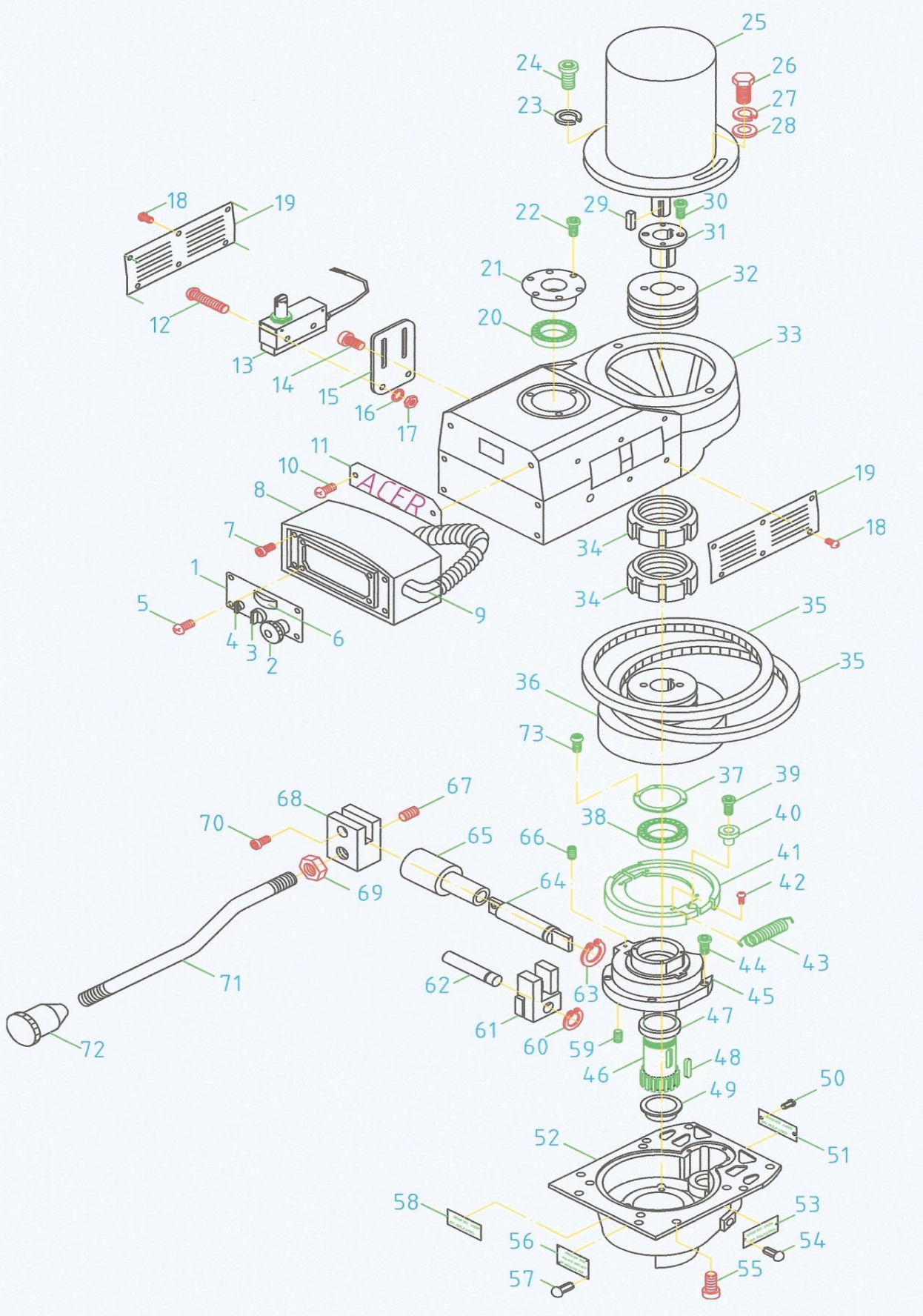

5HP E-mill HEAD BACK GEAR

ITEM NO.	PARTS NO.	FACTORY NO.	DESCRIPTION	Q'TY
40	8036	VS48	Brake Shoe Pivot Sleeve	1
41	5E8032	FVS47	Brake Shoe Assembly	1
42	8032-1	VS47-1	Round Cap Screw	4
43	8031	VS49	Brake Spring	2
44	H8064	VS51	Socket HD Cap Screw	4
45	5EH8053-2	FVS50-2	Belt Housing Base	1
46	5E8034-5	FVS70-1	Spindle Pulley Hub	1
47	5E8033	FVS98	Spindle Pulley Spacer	1
48	5E8049-1	FVS71-1	Key	1
49	5E7038	FVS105	Timing Pulley Clutch	
			Sleeve	1
50	8059	VS	Drive Screw	2
51	8063-2	VS01-1	Grease Add Name Plate	1
52	5EH8063	FVS82	Gear Housing	1
53	8058	VS82-2	Hi-Low Range Name Plate	1
54	8059	VS	Drive Screw	2
55	8055	VS12	Socket HD Cap Screw	8
56	8061	VS82-1	Quill Feed Name Plate	1
57	8059	VS	Drive Screw	4
58	H8063-1	VS82-3	Oil Add Name Plate	1
59	H8077	VS99	Socket Set Screw	1
60	8066	VS60	Snap Ring	1
61	8067	VS59	Brake Operating Finger	2
62	8068	VS58	Brake Finger Pivot Stud	1
63	8066-1	VS60-1	Snap Ring	1
64	H8074	VS53	Brake Lock Shaft	1
65	H8073	VS52	Sleeve for Brake Lock	
			Shaft	1
66	H8077	VS99	Socket Set Screw	1
67	8072	VS54-1	Socket Set Screw	1
68	8070-2	VS54	Brake Handle Block	1
69	8070-1	VS56-1	Hex Nut	1
70	8071-1	VS55-1	Socket HD Cap Screw	1
71	5E8070	FVS56	Brake Lock Handle	1
72	8069	VS57	Bakelite Ball Handle	1
73	5EH8053-4		Round Socket Cap Screw	4

8-9. 3VS & 3VSII Basic Machine

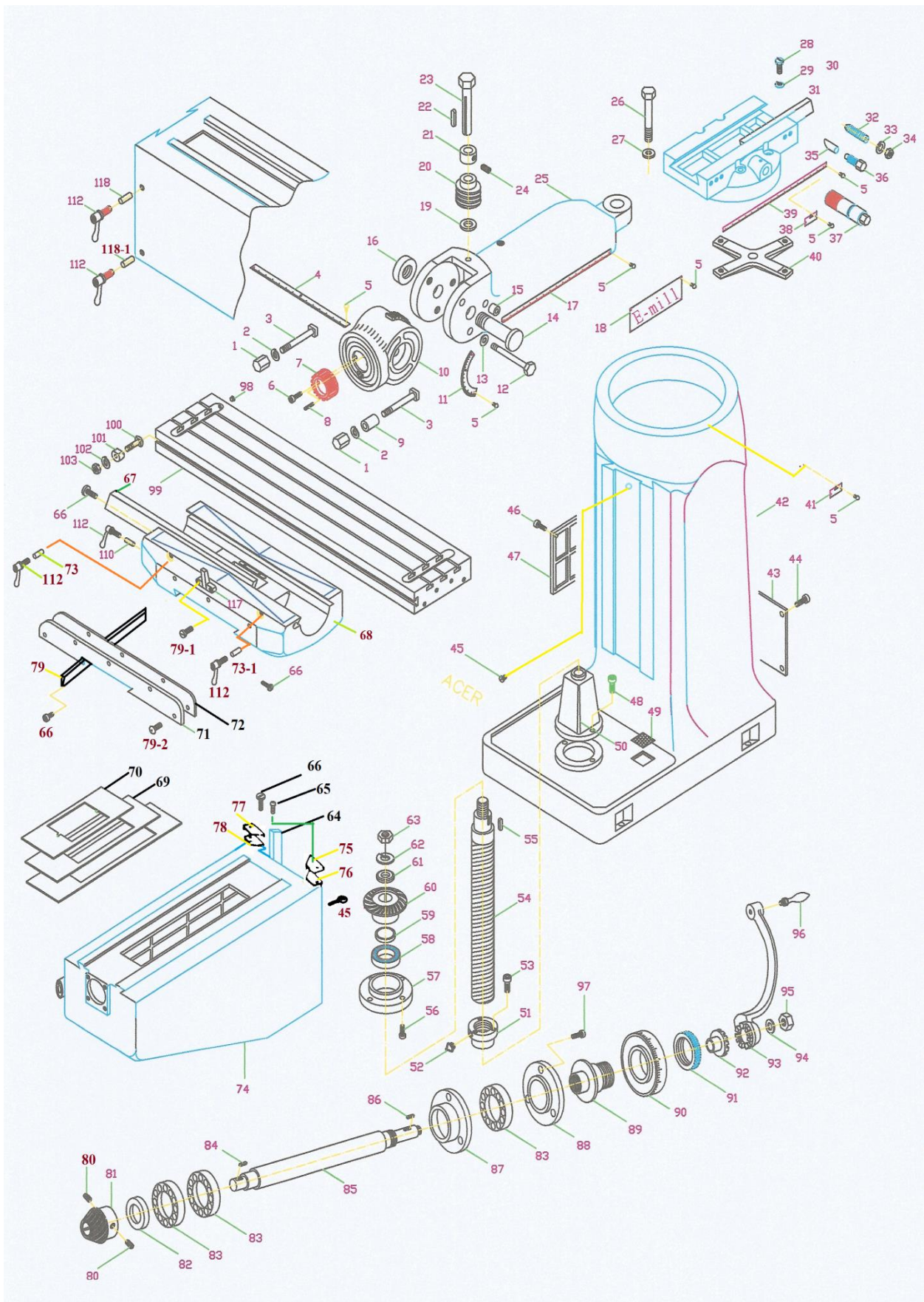

3VS & 3VSII Basic Machine

ITEM NO.	PARTS NO.	FACTORY NO.	DESCRIPTION	QT'Y
1	5038	B157	Lock Nut	4
2	6244-1		Spring Washer	4
3	6244		Chem Blacked RD.HD.Screws 16	4
4	5016	C03	Ram Adapter Plate	1
5	5032	C16	Round HD Drive Screw	15
6	5035	C13	Socket Cap Screw M8X35	2
7	5033	C01	Quill Housing ADJ.Gear	1
8	5034	C14	Roll Dowel Pin 6X30	1
9	6120	B156	Lower Clamping Bolt Spacer	2
10	5019	C02	Ram Adapter	1
11	5043	C15	Angle Plate	1
12	5028	C19	Adapter Locking Bolt 190L	3
13	5029	C18	Chamfered & Hardened Washer 1/2	7
14	5026	C17	Adapter Pivot Pin	1
15	H5028-1	C10-1	Adapter Locking Bolt Washer	1
16	5027	C04	Pivot Shaft Nut	1
17	5044		Ram Plate	1
18	5018-2		Series Name Plate	1
19	5021-1		Spacer	1
20	5020	C06	Vertical Adjusting Worm	1
21	5022	C07-1	Worm Thrust Washer	1
22	5023-1	C09	Worm Key 5X5X50	1
23	5021	C08	Vertical Adjusting Worm Shaft 166L	1
24	5023	C05	Set Screw 6X8	1
25	5018	C10	Ram	1
26	5004	C127	Turret Locking Bolt	4
27	5005	C18	Chamfered x Hardened Washter 1/2"	4
28	5015	C128	Ram Pinion Screw	1
29	5015-1		Washer	1
30	5001	C52	Turret	1
31	5002	C111	Ram / Turret Gib	1
32	H 5007-2	C110	Gib Screw	3
33	H 5008		Spring Washer	3

3VS & 3VSII Basic Machine

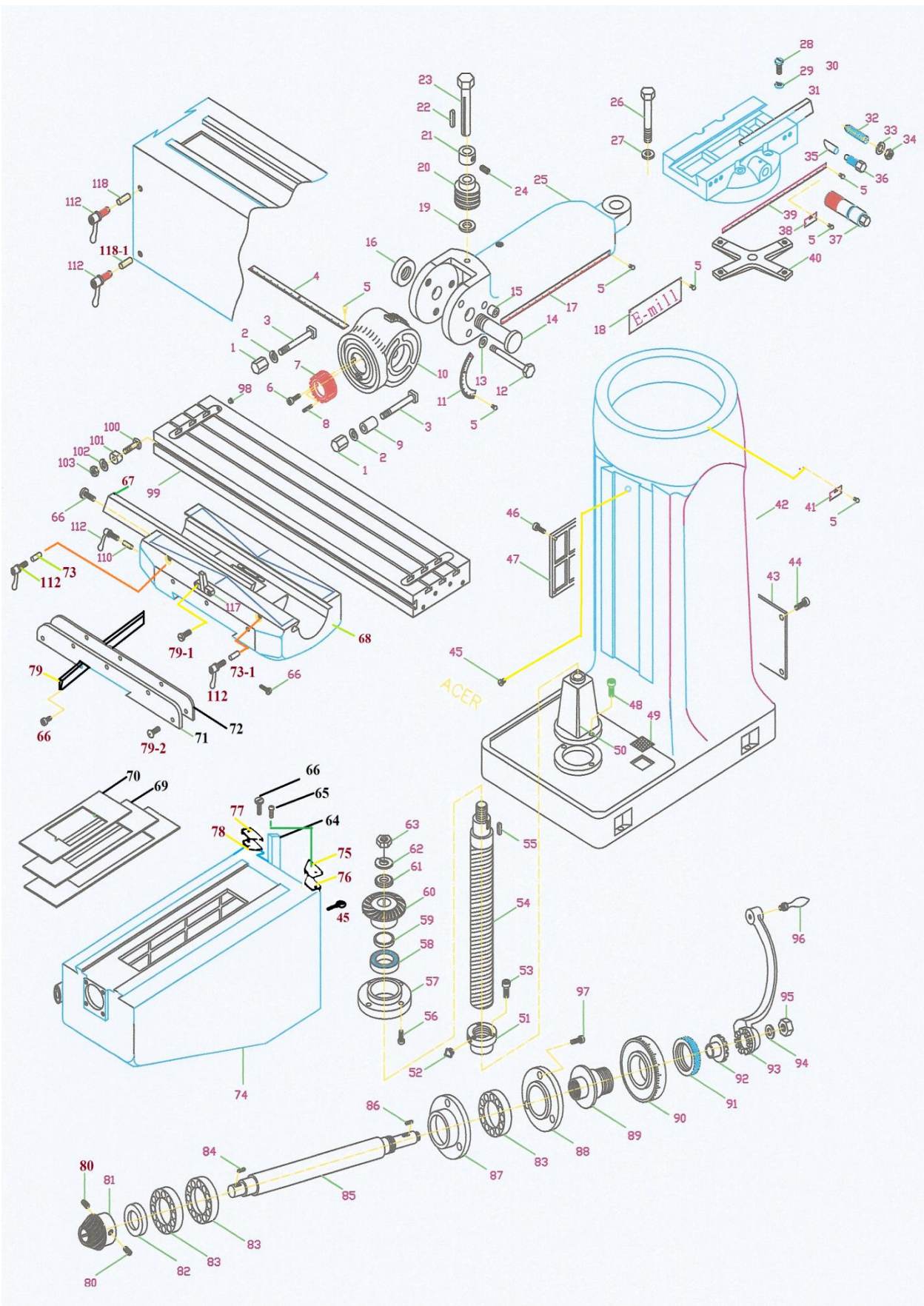

3VS & 3VSII Basic Machine

ITEM NO.	PARTS NO.	FACTORY NO.	DESCRIPTION	QT'Y
34	H 5007-1	C125	Gib Screw Nut 3/8	2
35	H 5006	C125	Ram Lock Plunger	2
36	5009-1	C119	Ram Lock Stud	2
37	5012	C120	Ram Pinion	1
38	5031	C21	Plate	3
39	5030	C126	Turret Plate	1
40	5003	C118	Spider	1
41	5031	C21	Plate	2
42	1001	C98	Column	1
43	1001-6		Column Back Cover	1
44	1001-7		Round HD + Screw 5x8mm	4
45	1001-2	C45	Stop Screw	2
46	H 1003	C29	Socket Head Cap Screw 6X16	4
47	H 1002	C28	Column Cover	1
48	4027	C102	Socket Head Cap Screw M10X35	2
49	1004	C130-1	Filter	2
50	4026	C103	Pedestal	1
51	4024	C104	Elevating Screw Nut	1
52	4024-1	C106	Grease Nipple	1
53	4025	C105	Socket Head Cap Screw 6X16	3
54	4021	C82	Elevating Screw Assembly	1
55	4020	C75	Key 5X5X20	1
56	4041	C81	Socket Head Cap Screw 8X20	3
57	8039	C80	Bearing Retainer Ring	1
58	4040	C79	Sealed Ball Bearing 5305	1
59	4022-1		Washer	1
60	4019	C77	Bevel Gear	1
61	4022		Washer	1
62	4022-2		Spring Washer	1
63	4023	C74	Jam Nut 1/2NF	1
64	4038	C55	Knee / Column Gib	1
65	4001-4		Round HD + Screw 5x12mm	6
66	3028	C41	Gib Adjusting Screw	6
67	3026	C43	Saddle / Table Gib	1
68	3001-1	C52-1	Saddle	1

3VS & 3VSII Basic Machine

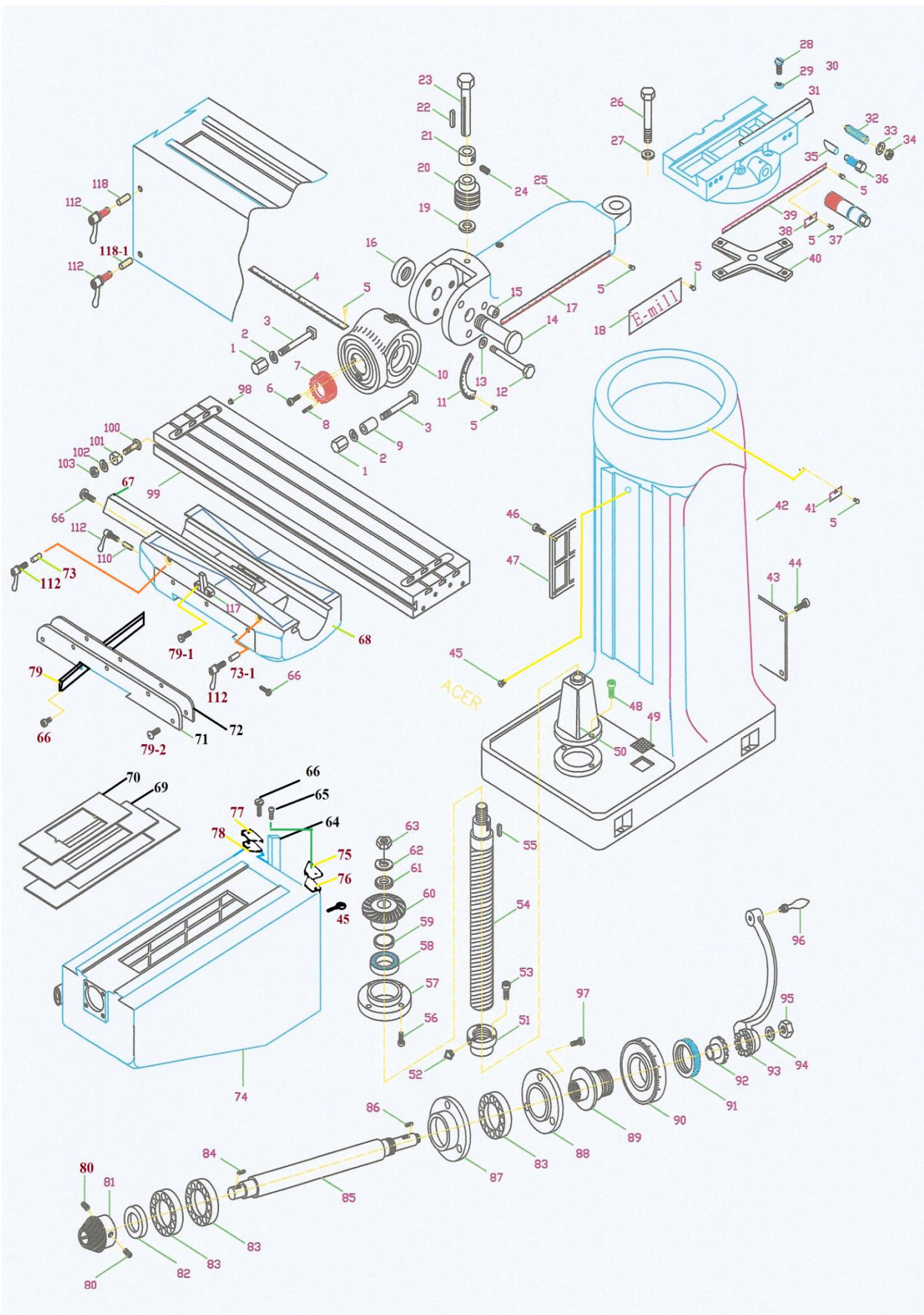

3VS & 3VSII Basic Machine

ITEM NO.	PARTS NO.	FACTORY NO.	DESCRIPTION	QT'Y
69	3039	C61	Chip Guards Plate Lower	1
70	3040	C59	Chip Guards Plate Upper	1
71	3037-2	C50	Saddle Knee Wiper Plate	2
72	3037	C44	Felt Wipers	2
73	3029	C46	Table Lock Plunger 20L	1
73-1	3029-1	C46	Table Lock Plunger 25L	1
74	4001	C62	Knee 12"	1
75	4028-3	C57	Right knee Wiper Plate	1
76	4028	C58	Knee Wiper Felt	1
77	4028-2	C53	Left Hand Column Wiper Holder	1
78	4028-1	C54	Knee Wiper Felt	1
79	3027	C49	Saddle / Knee Gib	1
79-1	3036	C40	Socket HD Cap Screw 8X12mm	2
79-2	4001-5		Round HD + Screw 5x16mm	6
80	4014-1		Set Screw 6X8	2
81	4014	C96	Bevel Pinion Gear	1
82	4013-1		Washer	1
83	2008	D8	Grease Sealed Bearing 6204	3
84	4015	C93	Key 3x3x18	1
85	4017	C94	Elevating Shaft for 12" knee	1
86	4015	C93	Key 3x3x18	1
87	4006	C92	Bearing Cap	1
88	2011	C90	Bearing Retaining Ring	1
89	4011	C88	Dial Holder	1
90	4010	C87	Dial With 100 Graduations	1
91	2016	C86	Dial Lock Nut	1
92	4013	C85	Gearshift Clutch Insert	1
93	4002	C84	Elevating Crank	1
94	4017-1		Washer	1
95	4017-2		Hex Nut	1
96	4003	C83	Handle	1
97	4009	C89	Socket Head Cap Screw M6X16	3
98	2035	C23-1	Plug	2
99	2001-50	C23	Table 50"	2
100	2031	C31	Stop Piece T-Bolt	2

3VS & 3VSII Basic Machine

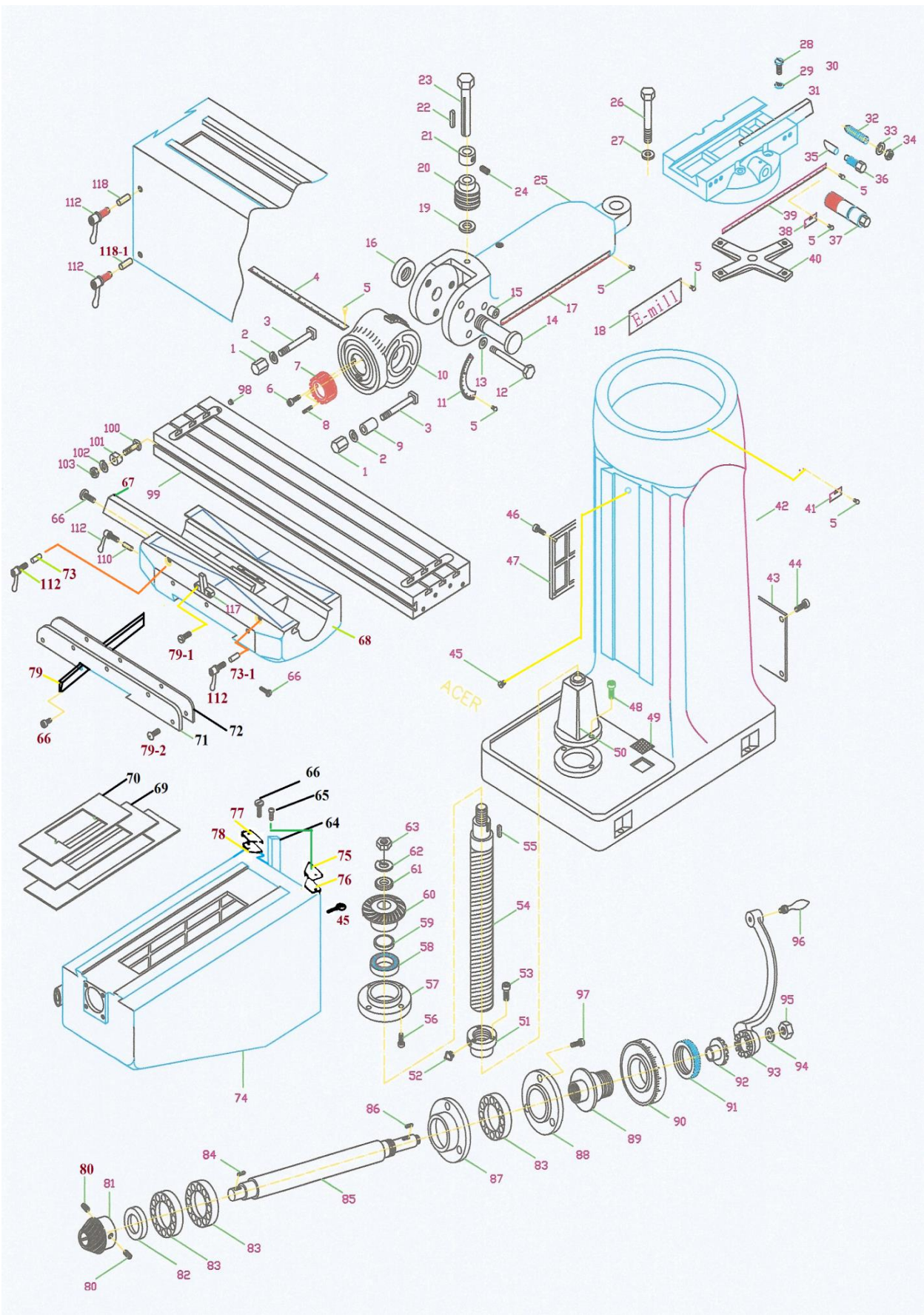

3VS & 3VSII Basic Machine

ITEM NO.	PARTS NO.	FACTORY NO.	DESCRIPTION	QT'Y
101	2030	C32	Table Stop Bracket Piece	2
102	2031-1		Spring Washer	2
103	2032	C33	Hex Nut 3/8	2
110	3032	C39	Saddle Lock Plunger	1
110-1	3032-1	C39	Saddle Lock Plunger	1
112	3031	C37	Table Lock Bolt Handle	6
	3030	C38	Saddle Lock Bolt	6
117	3035	C42	Table Stop Bracket	1
118	4043	C46	Knee Lock Plunger 61L	1
118-1	4044	C46	Knee Lock Plunger 64L	1

8-10. 3VK Basic Machine

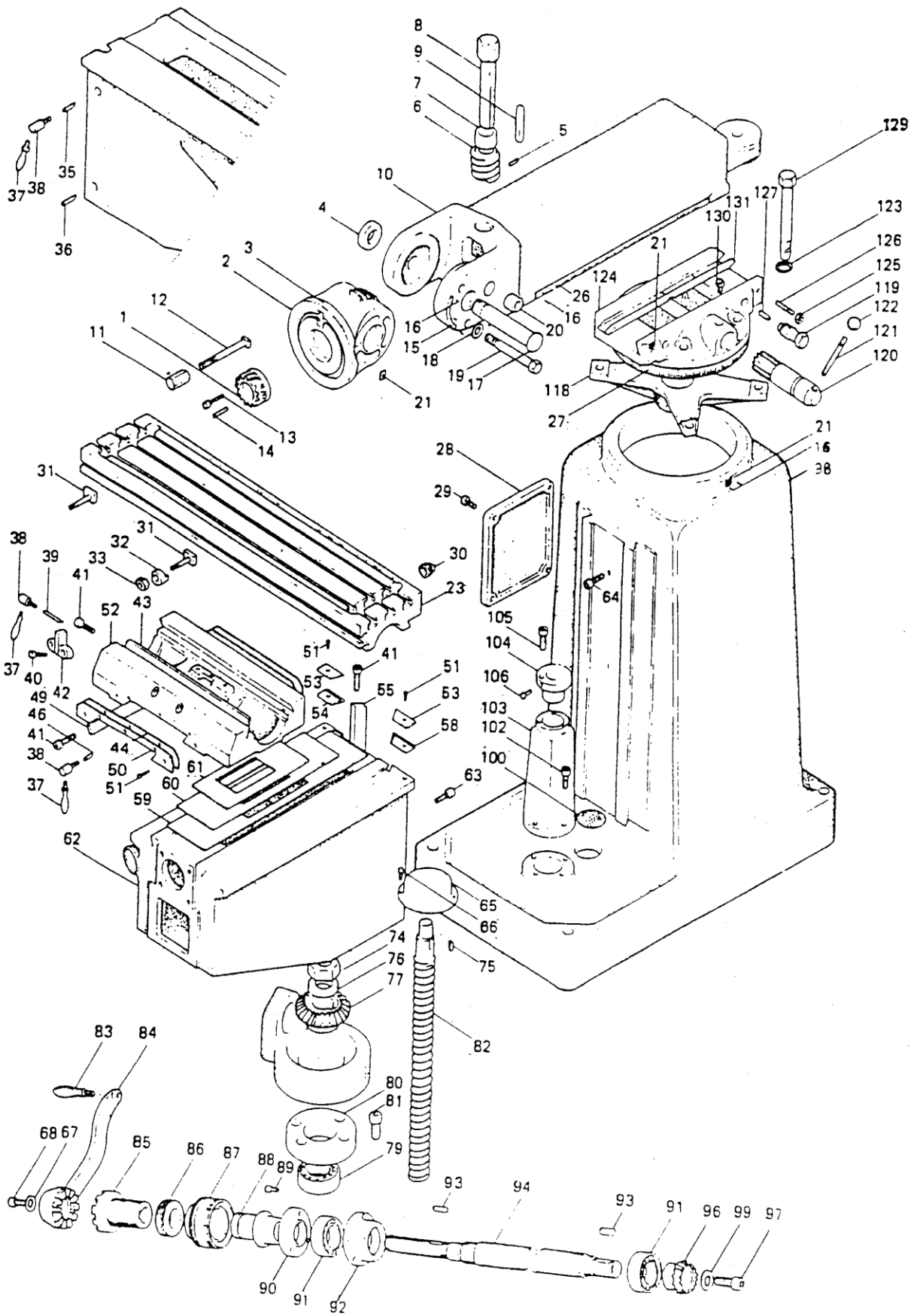

3VK Basic Machine

ITEM NO.	PARTS NO.	FACTORY NO.	DESCRIPTION	QT'Y
1	5033	C01	Quill Housing ADJ.Gear	1
2	5019	C02	Ram Adapter	1
3	5016	C03	Ram Adapter Plate	1
4	5027	C04	Pivot Shaft Nut	1
5	5023	C05	Set Screw 6X8	1
6	5020	C06	Vertical Adjusting Worm	1
7	5022	C07-1	Worm Thrust Washer	1
8	5021	C08	Vertical Adjusting Worm Shaft 166L	1
9	5023-1	C09	Worm Key 5X5X50	1
10	5018	C10	Ram	1
11	5038	B157	Nut	4
12	5036	B155	Locking Bolt	4
13	5035	C13	Socket Cap Screw M8X35	2
14	5034	C14	Roll Dowel Pin 6X30	1
15	5043	C15	Angle Plate	1
16	5032	C16	Round HD Drive Screw	15
17	5026	C17	Adapter Pivot Pin	1
18	5029	C18	Chamfered & Hardened Washer 1/2	7
19	5028	C19	Adapter Locking Bolt 190L	3
20	H 5028-1	C10-1	Adapter Locking Bolt Washer	1
21	5031	C21	Plate	3
23	2001-50	C23	Table 50"	2
26	H 5044	C10-1	Ram Plate	1
27	5030	C126	Turret Plate	1
28	H 1002	C28	Column Cover	1
29	H 1003	C29	Socket Head Cap Screw 6X16	4
30	2035	C23-1	Plug	2
31	2031	C31	Stop Piece T-Bolt	2
32	2030	C32	Table Stop Bracket Piece	2
33	2032	C33	Hex Nut 3/8	2
35	4043	C46	Knee Lock Plunger 61L	1
36	4044	C46	Knee Lock Plunger 64L	1
37	3031	C37	Table Lock Bolt Handle	6
38	3030	C38	Saddle Lock Bolt	6

3VK Basic Machine

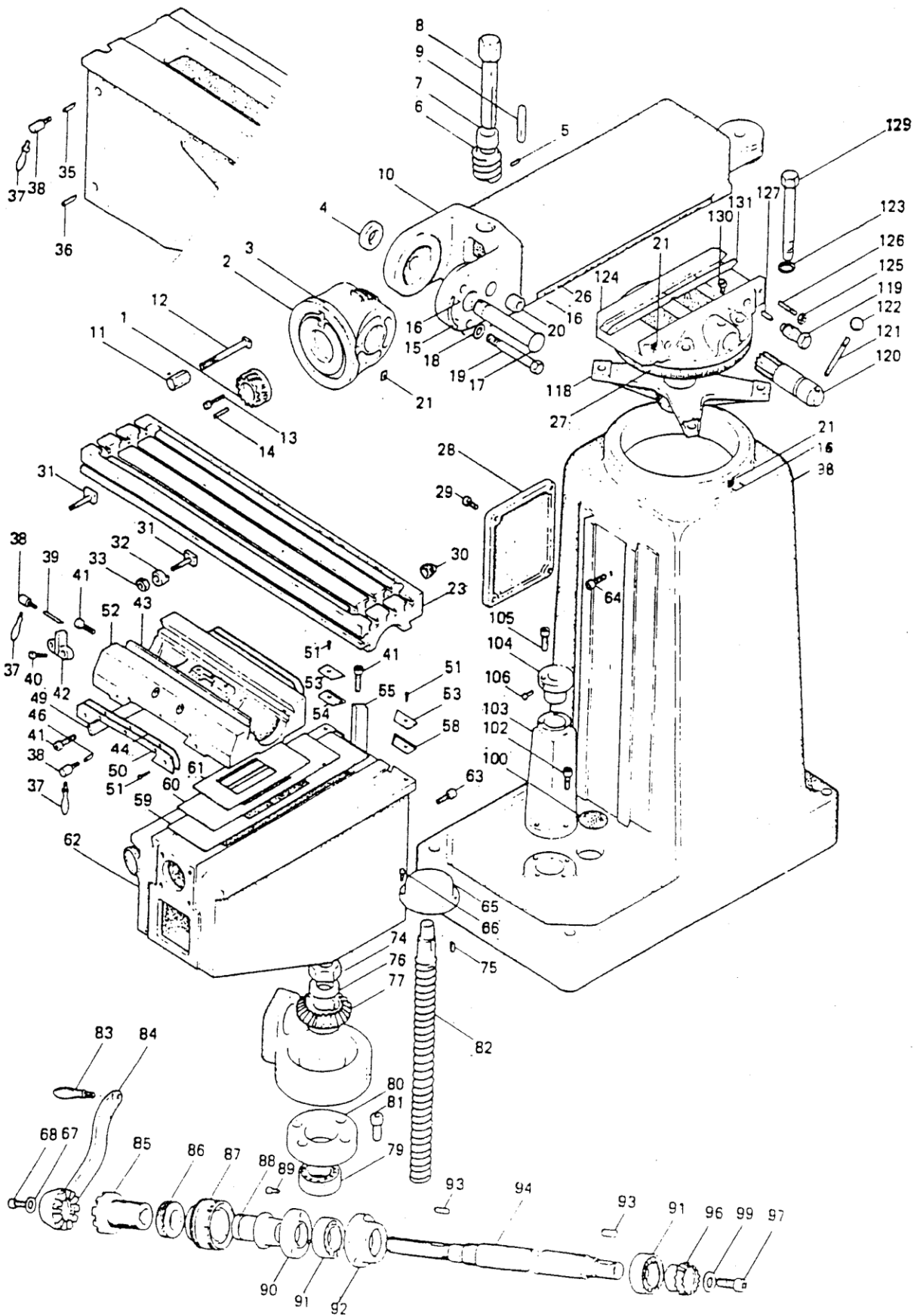

3VK Basic Machine

ITEM NO.	PARTS NO.	FACTORY NO.	DESCRIPTION	QT'Y
39	3032	C46	Saddle Lock Plunger	1
39-1	3032-1	C46	Saddle Lock Plunger	1
40	3036	C40	Socket HD Cap Screw 10X16	2
41	3028	C41	Gib Adjusting Screw	6
42	3035	C42	Table Stop Bracket	1
43	3026	C43	Saddle / Table Gib	1
44	3037	C44	Felt Wipers	2
46	3029	C46	Table Lock Plunger 20L	1
46-1	3029-1	C46	Table Lock Plunger 25L	1
47	3030	C47	Table Lock Bolt	6
48	30311	C48	Table Lock Bolt Handle	6
49	3027	C49	Saddle / Knee Gib	1
50	3037-2	C50	Saddle Knee Wiper Plate	2
51	3038	C51	Oval Head Screw 5X12	12
52	3001	C52	Saddle	1
53	4028-2	C53	Left Hand Column Wiper Holder	1
54	4028-1	C54	Knee Wiper Felt	1
55	4038	C55	Knee / Column Gib	1
56	4029	C56	Oval Head Screw	2
57	4028-3	C57	Right knee Wiper Plate	1
58	4028	C58	Knee Wiper Felt	1
60	3040	C59	Chip Guards Plate Upper	1
61	3039	C61	Chip Guards Plate Lower	1
62	4001	C62	Knee 16"	1
63	1001-1	C63	Stop Screw	1
64	1001-2	C45	Stop Screw	1
65	3030	C38	Knee Lock Bolt	2
66	3031	C37	Knee Lock Bolt Handle	2
69	4001-1	C46	Knee Lock Plunger	2
74	4023	C74	Jam Nut 1/2NF	1
75	4020	C75	Key 5X5X20	1
76	4022	C76	Washer	1
77	4019	C77	Bevel Gear	1
79	4040	C79	Sealed Ball Bearing 5305	1

3VK Basic Machine

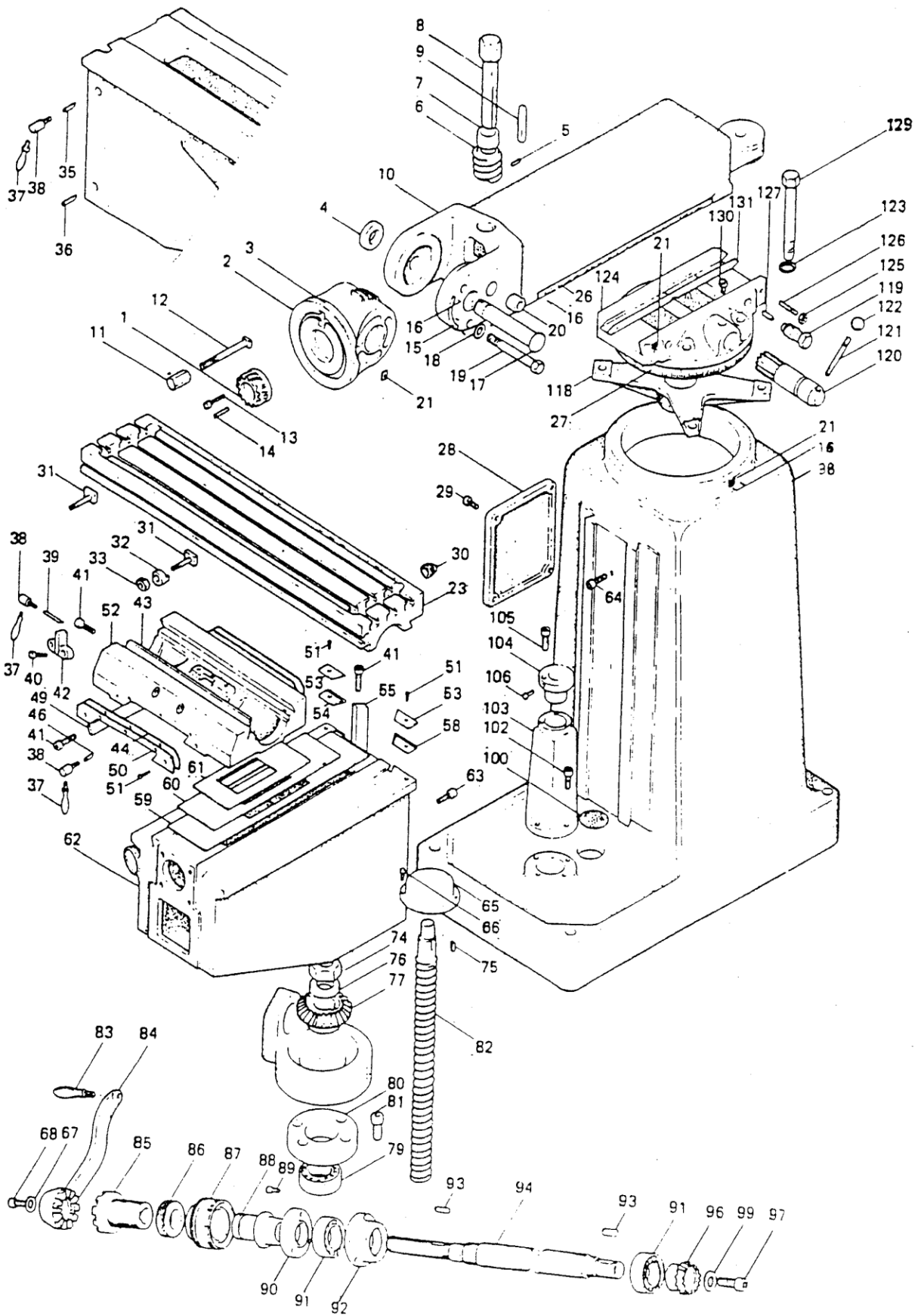

3VK Basic Machine

ITEM NO.	PARTS NO.	FACTORY NO.	DESCRIPTION	QT'Y
80	8039	C80	Bearing Retainer Ring	1
81	4041	C81	Socket Head Cap Screw 8X20	3
82	4021	C82	Elevating Screw Assembly	1
83	4003	C83	Handle	1
84	4002	C84	Elevating Crank	1
85	4013	C85	Gearshift Clutch Insert	1
86	2016	C86	Dial Lock Nut	1
87	4010	C87	Dial With 100 Graduations	1
87-1	4010-1		Spacers	
88	4011	C88	Dial Holder	1
88-1	4011-1		Set Screw	
89	4009	C89	Socket Head Cap Screw M6X16	3
90	2011	C90	Bearing Retaining Ring	1
91	2008	D8	Grease Sealed Bearing 6204	3
92	4006	C92	Bearing Cap	1
93	4015	C93	Key 3X3X18	2
94	4017	C94	Elevating Shaft for 12" Knee	1
95	4016	C95	Sealed Ball Bearing 6204ZZ	2
96	4014	C96	Bevel Pinion Gear	1
97	4042	C97	Set Screw	1
98	1001	C98	Column	1
99	4017-1		Spacer Washer	1
102	4027	C102	Socket Head Cap Screw M10X35	2
103	4026	C103	Pedestal	1
104	4024	C104	Elevating Screw Nut	1
105	4025	C105	Socket Head Cap Screw 6X16	3
106	4024-1	C106	Grease Nipple	1
118	5003	C118	Spider	1
119	5009-1	C119	Ram Lock Stud	2
120	5012	C120	Ram Pinion	1
121	5013	C121	Ram Pinion Handle	1
122	5014	C122	Plastic Ball	1
123	5005	C18	Chamfered x Hardened Washer 1/2"	4
124	5001	C52	Turret	1
125	H 5007-1	C125	Gib Screw Nut 3/8	2

3VK Basic Machine

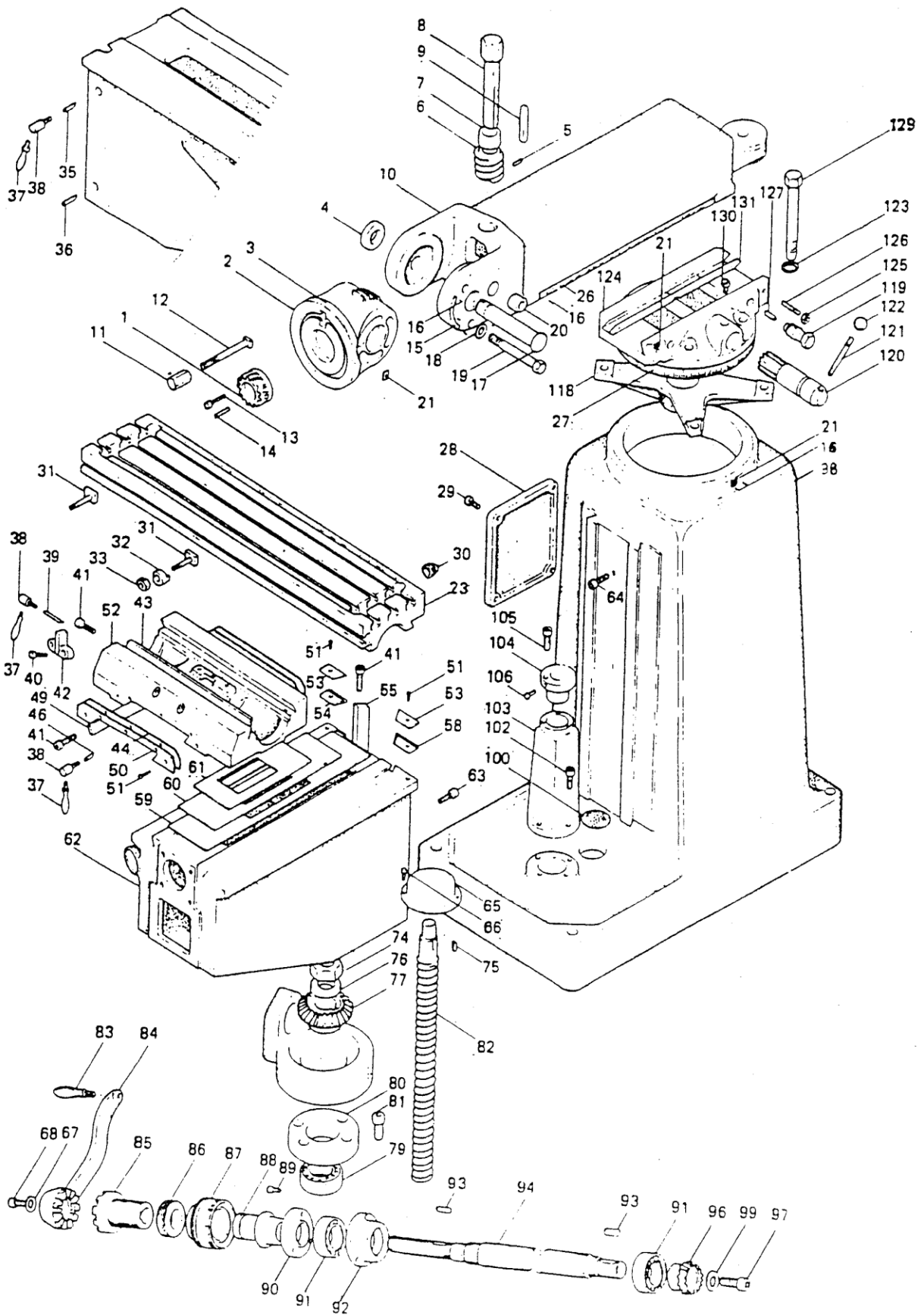

3VK Basic Machine

ITEM NO.	PARTS NO.	FACTORY NO.	DESCRIPTION	QT'Y
126	H 5007	C110	Gib Screw	2
127	H 5006	C125	Ram Lock Plunger	2
129	5004	C127	Turret Locking Bolt	4
130	5015	C128	Ram Pinion Screw	1
130-1	5015-1		Spring Washer	1
131	5002	C111	Ram / Turret Gib	1

8-11. 3VKH Basic Machine

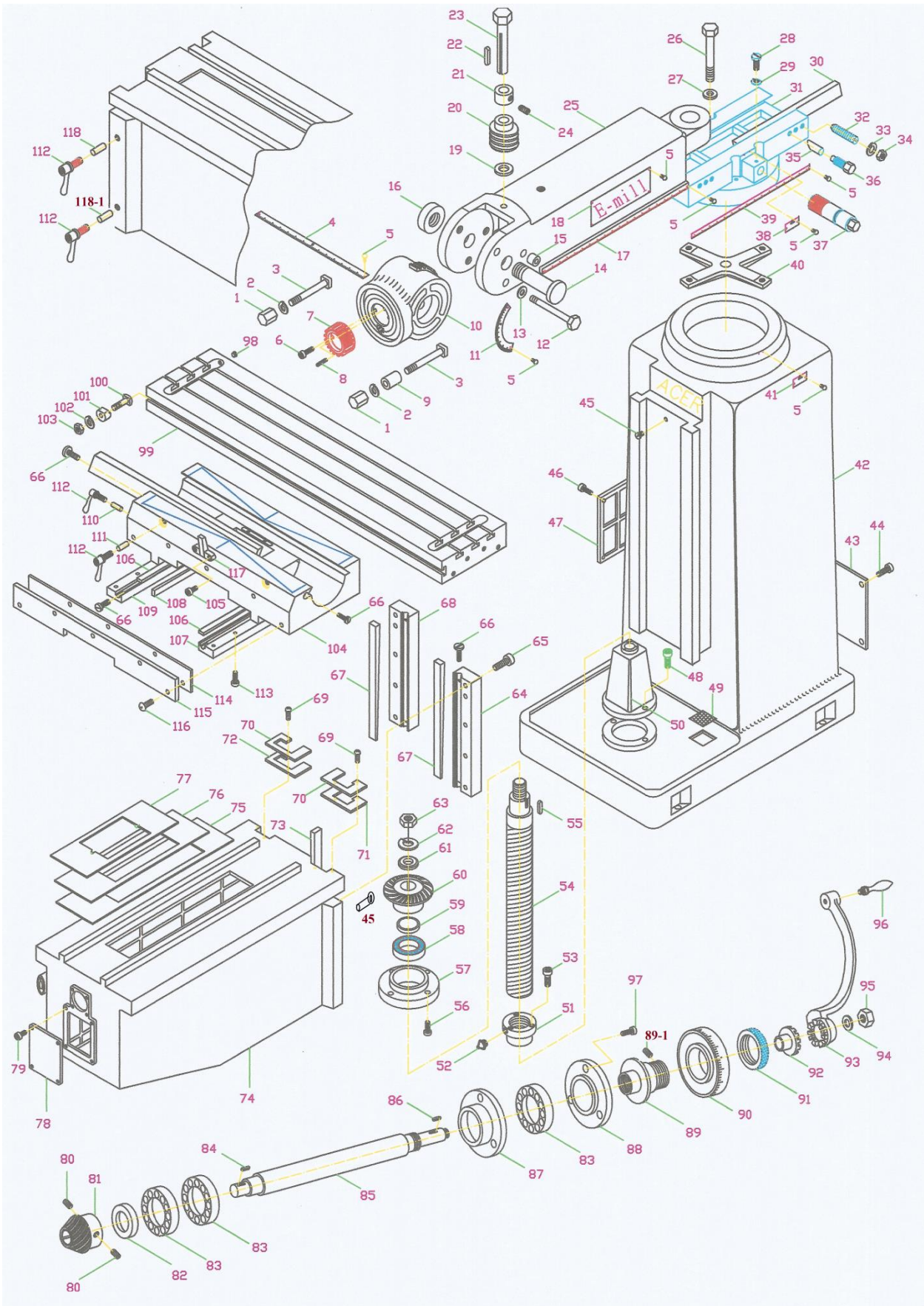

3VKH Basic Machine

ITEM NO.	PARTS NO.	FACTORY NO.	DESCRIPTION	QT'Y
1	5038	B157	Lock Nut	4
2	6244-1		Spring Washer	4
3	6244		Chem Blacked RD.HD.Screws 16	4
4	5016	C03	Ram Adapter Plate	1
5	5032	C16	Round HD Drive Screw	15
6	5035	C13	Socket Cap Screw M8X35	2
7	5033	C01	Quill Housing ADJ.Gear	1
8	5034	C14	Roll Dowel Pin 6X30	1
9	6120	B156	Lower Clamping Bolt Spacer	2
10	5019	C02	Ram Adapter	1
11	5043	C15	Angle Plate	1
12	5028	C19	Adapter Locking Bolt 190L	3
13	5029	C18	Chamfered & Hardened Washer 1/2	7
14	5026	C17	Adapter Pivot Pin	1
15	H5028-1	C10-1	Adapter Locking Bolt Washer	1
16	5027	C04	Pivot Shaft Nut	1
17	5044		Ram Plate	1
18	5018-2		Series Name Plate	2
19	5021-1		Spacer	1
20	5020	C06	Vertical Adjusting Worm	1
21	5022	C07-1	Worm Thrust Washer	1
22	5023-1	C09	Worm Key 5X5X50	1
23	5021	C08	Vertical Adjusting Worm Shaft 166L	1
24	5023	C05	Set Screw 6X8	1
25	5018	C10	Ram	1
26	5004	C127	Turret Locking Bolt	4
27	5005	C18	Chamfered x Hardened Washer 1/2"	4
28	5015	C128	Ram Pinion Screw	1
29	5015-1		Washer	1
30	5002	C111	Ram / Turret Gib	1
31	5001	C52	Turret	1
32	H 5007-2	C110	Gib Screw	3
33	H 5008		Spring Washer	3

3VKH Basic Machine

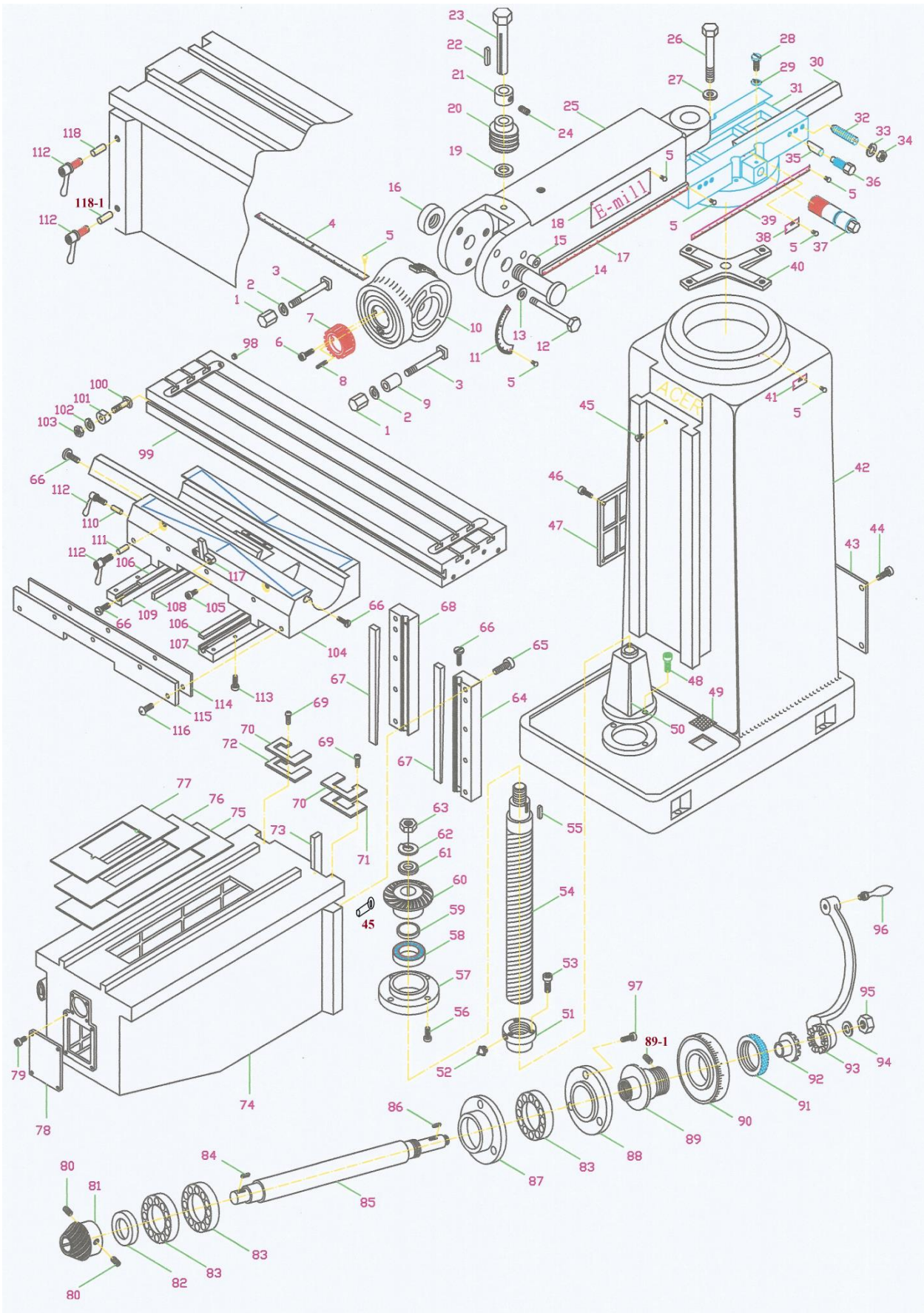

3VKH Basic Machine

ITEM NO.	PARTS NO.	FACTORY NO.	DESCRIPTION	QT'Y
34	H 5007-1	C125	Gib Screw Nut 3/8	3
35	H 5006	C125	Ram Lock Plunger	2
36	5009-1	C119	Ram Lock Stud	2
37	5012	C120	Ram Pinion	1
38	5031	C21	Plate	3
39	5030	C126	Turret Plate	1
40	5003	C118	Spider	1
41	5031	C21	Plate	2
42	1001	C98	Column	1
43	1001-6		Column Back Cover	1
44	1001-7		Round HD + Screw 5x8mm	4
45	1001-2	C45	Stop Screw	2
46	H 1003	C29	Socket Head Cap Screw 6X16	4
47	H 1002	C28	Column Cover	1
48	4027	C102	Socket Head Cap Screw M10X35	2
49	1004	C130-1	Filter	2
50	4026	C103	Pedestal	1
51	4024	C104	Elevating Screw Nut	1
52	4024-1	C106	Grease Nipple	1
53	4025	C105	Socket Head Cap Screw 6X16	3
54	4021	C82	Elevating Screw Assembly	1
55	4020	C75	Key 5X5X20	1
56	4041	C81	Socket Head Cap Screw 8X20	3
57	8039	C80	Bearing Retainer Ring	1
58	4040	C79	Sealed Ball Bearing 5305	1
59	4022-1		Washer	1
60	4019	C77	Bevel Gear	1
61	4022		Washer	1
62	4022-2		Spring Washer	1
63	4023	C74	Jam Nut 1/2NF	1
64	4H-4051		Knee/Column Gib Support	1
65	4H-4052		Socket Head Cap Screw	10
66	3028	C41	Gib Adjusting Screw	6
67	4H-4053		Knee/Column Gib	2

3VKH Basic Machine

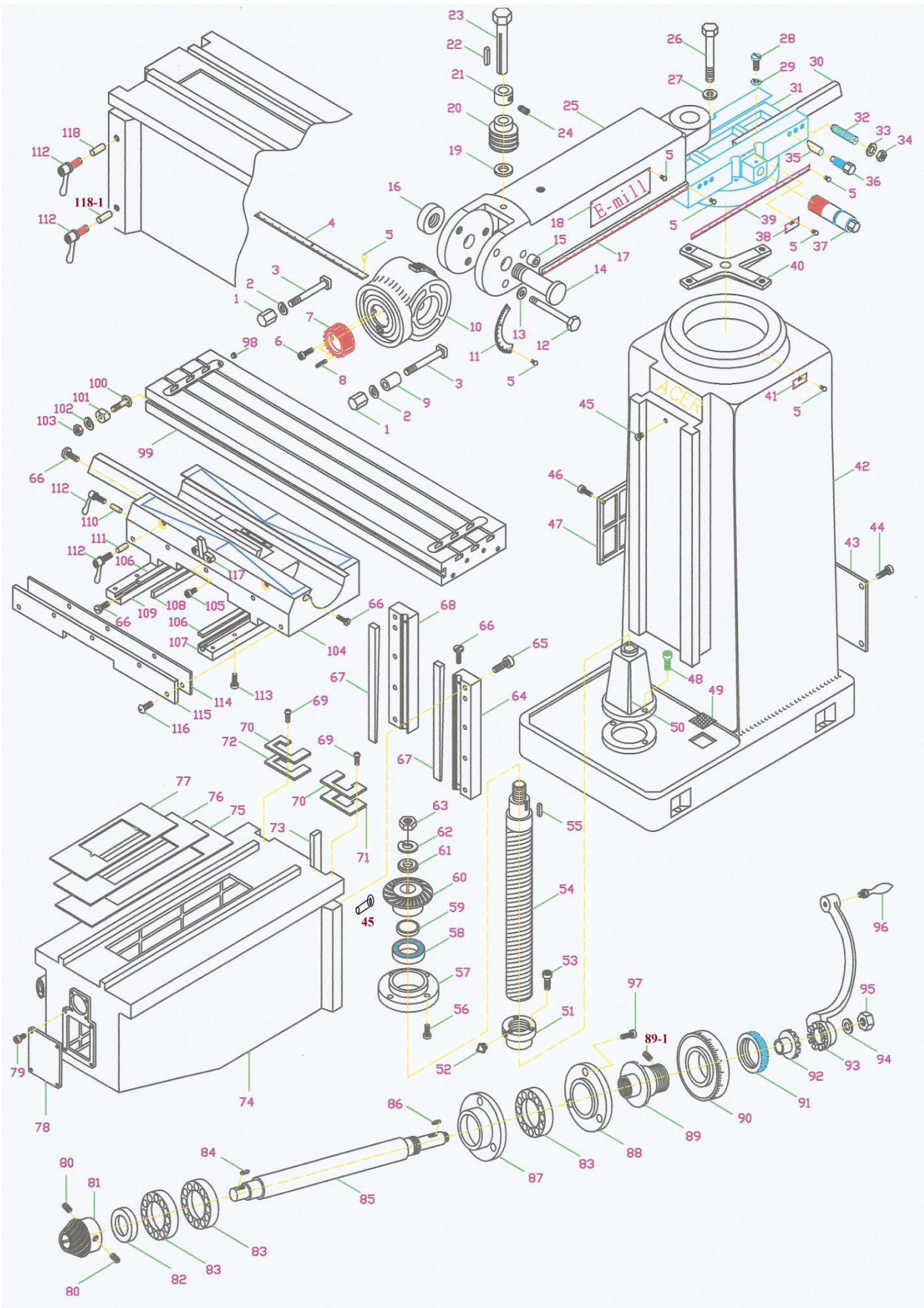

3VKH Basic Machine

ITEM NO.	PARTS NO.	FACTORY NO.	DESCRIPTION	QT'Y
68	4H-4050		Knee/Column Gib Support	1
69	3038		Oval Head Screw	8
70	4H-4028-2	C53H	Wiper Holder	1
71	4H-4028	C54H	Right Knee Wiper Felt	1
72	4H-4028-1	C58H	Left Knee Wiper Felt	1
73	4H-4038		Knee/Column Gib	1
74	4H-4001		Knee 18"	1
75	4H-3039	C60-627	Chip Guards Plate Lower	1
76	3039	C60-490	Chip Guards Plate Middle	1
77	3040	C60-370	Chip Guards Plate Upper	1
78	3B-1005		Knee Cover	1
79	3B-1005-1		Socket Head Cap Screw	4
80	4014-1		Set Screw 6X8	2
81	4014	C96	Bevel Pinion Gear	1
82	4013-1		Washer	1
83	2008	D8	Grease Sealed Bearing 6204	3
84	4015	C93	Key 3x3x18	1
85	4017	C94	Elevating Shaft for 12" knee	1
86	4015	C93	Key 3x3x18	1
87	4006	C92	Bearing Cap	1
88	2011	C90	Bearing Retaining Ring	1
89	4011	C88	Dial Holder	1
89-1	4011-1		Set Screw	1
90	4010	C87	Dial With 100 Graduations	1
91	2016	C86	Dial Lock Nut	1
92	4013	C85	Gearshift Clutch Insert	1
93	4002	C84	Elevating Crank	1
94	4017-1		Washer	1
95	4017-2		Hex Nut	1
96	4003	C83	Handle	1
97	4009	C89	Socket Head Cap Screw M6X16	3
98	2035	C23-1	Plug	2
99	2001-50	C23	Table 50"	1
	2001-54	C23-54	Table 54"	1
100	2031	C31	Stop Piece T-Bolt	2

3VKH Basic Machine

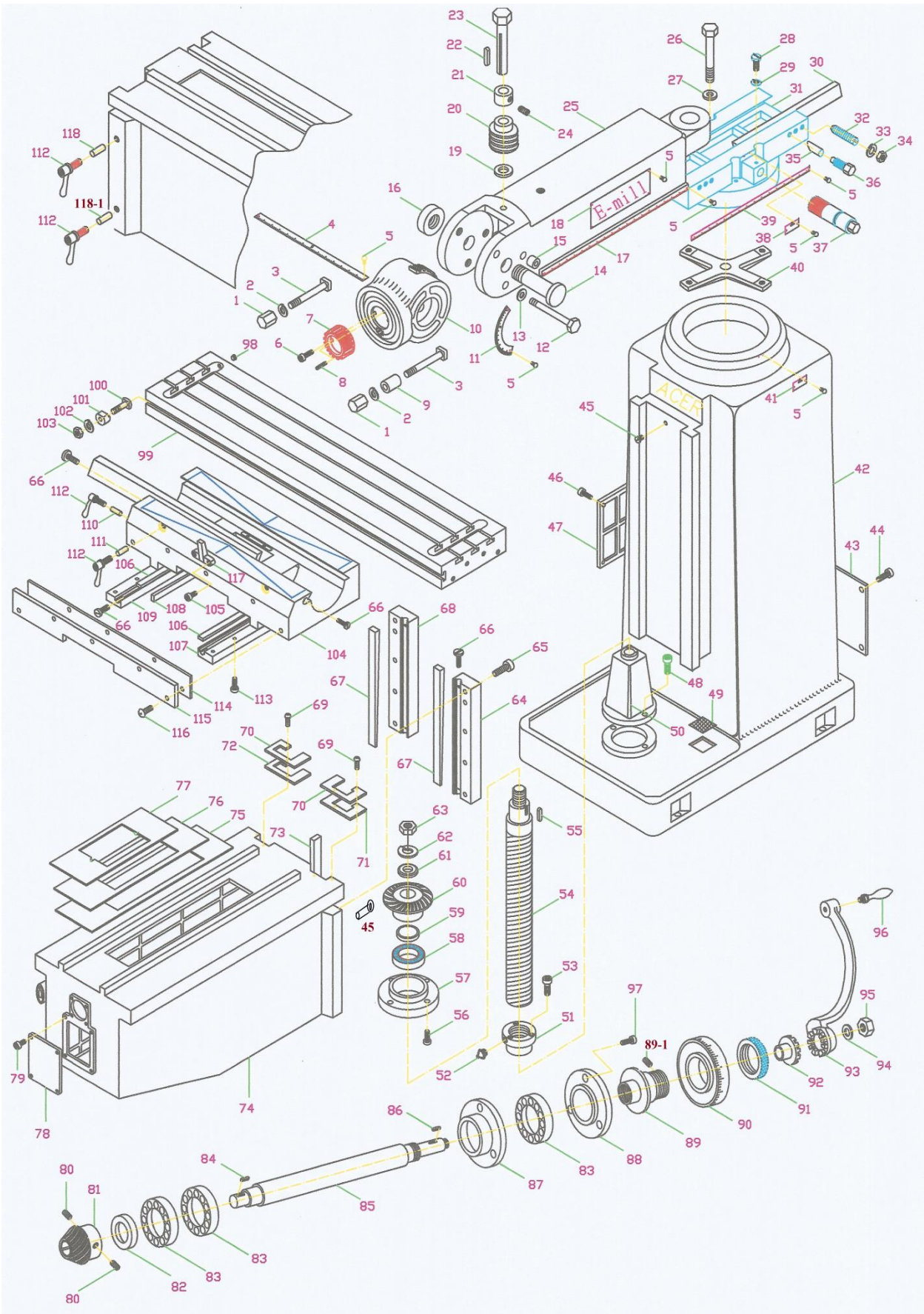

3VKH Basic Machine

ITEM NO.	PARTS NO.	FACTORY NO.	DESCRIPTION	QT'Y
101	2030	C32	Table Stop Bracket Piece	2
102	2031-1		Spring Washer	2
103	2032	C33	Hex Nut 3/8	2
104	4H-3001		Saddle	1
105	3036	C40	Socket HD Cap Screw 8X12mm	2
106	4H-3027-1		Saddle / Knee Gib	2
107	4H-3050		Saddle/Table Gib Support-Right	1
108	4H-3027		Saddle / Knee Gib	1
109	4H-3050-1		Saddle/Table Gib Support-Left	1
110	4H-3032	C39	Saddle Lock Plunger	1
110-1	4H-3032-1	C39	Saddle Lock Plunger	1
111	H-3029	C46	Table Lock Plunger 20L	1
111-1	H-3029-1	C46	Table Lock Plunger 25L	1
112	3031	C37	Table Lock Bolt Handle	6
112-1	3030	C38	Saddle Lock Bolt	6
113	4H-3052		Socket Head Cap Screw	8
114	4H-3037	C44H	Felt Wipers	2
115	4H-3037-1	C50H	Saddle Knee Wiper Holder	2
116	3038		Round HD + Screw 5x16mm	10
117	3035	C42	Table Stop Bracket	1
118	4H-4043	C46	Knee Lock Plunger	1
118-1	4H-4044	C46	Knee Lock Plunger	1

8-12. 5VK Basic Machine

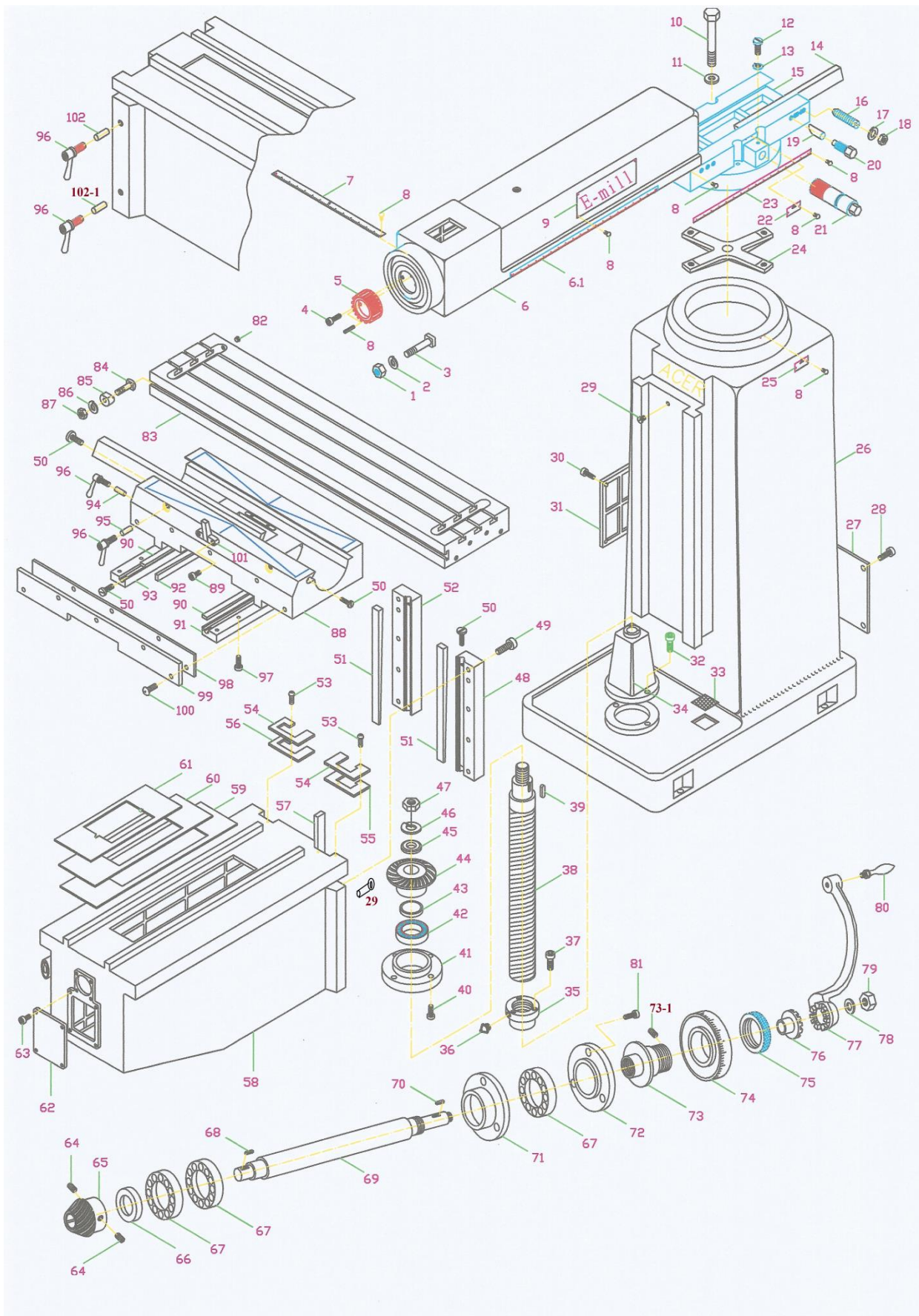

5VK Basic Machine

ITEM NO.	PART NO.	FACTOTRY NO.	DESCRIPTION	QT'Y
1	5K-5038	A070L	Lock Nut	4
2	5K-5037		Spring Washer	4
3	5K-5036	A071L	T Bolt Assembly	4
4	5K-5035	C13	Socket Cap Screw M8X35	2
5	5K-5033	C01	Quill Housing ADJ.Gear	1
6	5K-5018		Ram	1
7	5K-5016		Ram Adapter Plate	1
8	5032	C16	Round HD Drive Screw	15
9	5018-2		Series Name Plate	2
10	5K-5004		Turret Locking Bolt	4
11	5K-5005		Chamfered x Hardened Washer 5/8"	4
12	5K-5015	C128	Ram Pinion Screw	1
13	5015-1		Washer	1
14	5K-5002		Ram / Turret Gib	1
15	5K-5001	C52	Turret	1
16	H-5007-2	C110	Gib Screw	3
17	H-5008		Spring Washer	3
18	H-5007-1	C125	Gib Screw Nut 3/8	3
19	H-5006	C125	Ram Lock Plunger	2
20	H-5010	C108	Ram Lock Stud	2
21	5K-5012	C120	Ram Pinion	1
22	5031	C21	Plate	3
23	H-5044	C10-2	Ram Plate	1
24	5K-5003		Spider	1
25	5031	C21	Plate	2
26	4H-1001	C98	Column	1
27	1001-6		Column Back Cover	1
28	1001-7		Round HD + Screw 5x8mm	4
29	1001-2	C45	Stop Screw	2
30	H-1003	C29	Socket Head Cap Screw 6X16	4
31	H-1002	C28	Column Cover	1
32	4027	C102	Socket Head Cap Screw M10X35	2
33	1004	C130-1	Filter	2
34	4026	C103	Pedestal	1

5VK Basic Machine

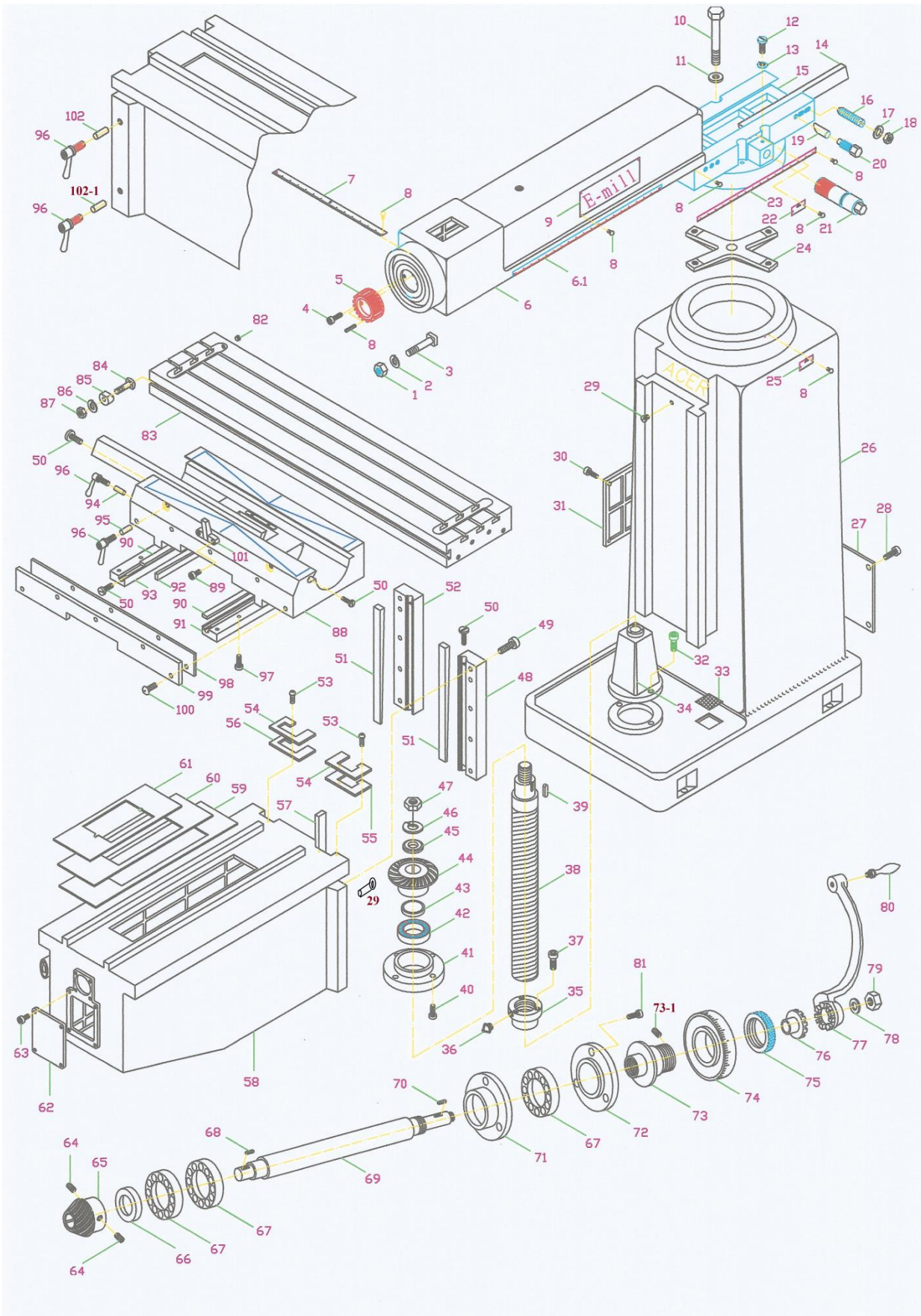

5VK Basic Machine

ITEM NO.	PART NO.	FACTORY NO.	DESCRIPTION	QTY
35	4024	C104	Elevating Screw Nut	1
36	4024-1	C106	Grease Nipple	1
37	4025	C105	Socket Head Cap Screw 6X16	3
38	4021	C82	Elevating Screw Assembly	1
39	4020	C75	Key 5X5X20	1
40	4041	C81	Socket Head Cap Screw 8X20	3
41	8039	C80	Bearing Retainer Ring	1
42	4040	C79	Sealed Ball Bearing 5305	1
43	4022-1		Washer	1
44	4019	C77	Bevel Gear	1
45	4022		Washer	1
46	4022-2		Spring Washer	1
47	4023	C74	Jam Nut 1/2NF	1
48	4H-4051		Knee/Column Gib Support	1
49	4H-4052		Socket Head Cap Screw	10
50	3028	C41	Gib Adjusting Screw	6
51	4H-4053		Knee/Column Gib	2
52	4H-4050		Knee/Column Gib Support	1
53	3038		Oval Head Screw	8
54	4H-4028-2	C53H	Wiper Holder	1
55	4H-4028	C54H	Right Knee Wiper Felt	1
56	4H-4028-1	C58H	Left Knee Wiper Felt	1
57	4H-4038		Knee/Column Gib	1
58	4H-4001		Knee 18"	1
59	4H-3039	C60-627	Chip Guards Plate Lower	1
60	3039	C60-490	Chip Guards Plate Middle	1
61	3040	C60-370	Chip Guards Plate Upper	1
62	3B-1005		Knee Cover	1
63	3B-1005-1		Socket Head Cap Screw	4
64	4014-1		Set Screw 6X8	2
65	4014	C96	Bevel Pinion Gear	1
66	4013-1		Washer	1
67	2008	D8	Grease Sealed Bearing 6204	3
68	4015	C93	Key 3x3x18	1
69	4017	C94	Elevating Shaft for 12" knee	1

5VK Basic Machine

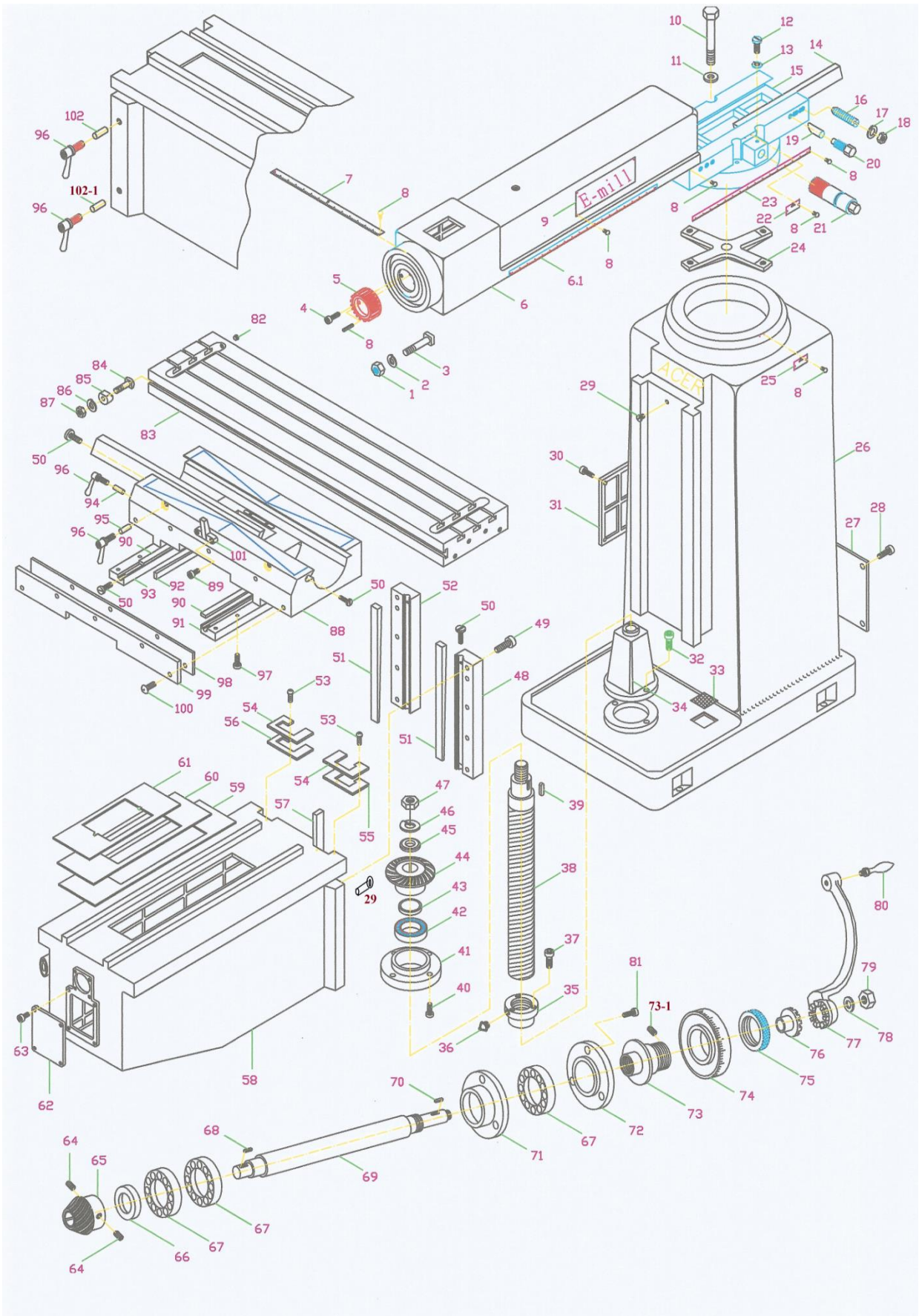

5VK Basic Machine

ITEM NO.	PART NO.	FACTORY NO.	DESCRIPTION	QTY
70	4015	C93	Key 3x3x18	1
71	4006	C92	Bearing Cap	1
72	2011	C90	Bearing Retaining Ring	1
73	4011	C88	Dial Holder	1
73-1	4011-1		Set Screw	1
74	4010	C87	Dial With 100 Graduations	1
75	2016	C86	Dial Lock Nut	1
76	4013	C85	Gearshift Clutch Insert	1
77	4002	C84	Elevating Crank	1
78	4017-1		Washer	1
79	4017-2		Hex Nut	1
80	4003	C83	Handle	1
81	4009	C89	Socket Head Cap Screw M6X16	3
82	2035	C23-1	Plug	2
83	2001-50	C23	Table 50"	1
83-1	2001-54	C23-54	Table 54"	1
84	2031	C31	Stop Piece T-Bolt	2
85	2030	C32	Table Stop Bracket Piece	2
86	2031-1		Spring Washer	2
87	2032	C33	Hex Nut 3/8	2
88	4H-3001		Saddle	1
89	3036	C40	Socket HD Cap Screw 8X12mm	2
90	4H-3027-1		Saddle / Knee Gib	2
91	4H-3050		Saddle/Table Gib Support-Right	1
92	4H-3027		Saddle / Knee Gib	1
93	4H-3050-1		Saddle/Table Gib Support-Left	1
94	4H-3032	C39	Saddle Lock Plunger	1
94-1	4H-3032-1	C39	Saddle Lock Plunger	1
95	H-3029	C46	Table Lock Plunger 20L	1
95-1	H-3029-1	C46	Table Lock Plunger 25L	1
96	3031	C37	Table Lock Bolt Handle	6
96-1	3030	C38	Saddle Lock Bolt	6
97	4H-3052		Socket Head Cap Screw	8
98	4H-3037	C44H	Felt Wipers	2
99	4H-3037-1	C50H	Saddle Knee Wiper Holder	2

5VK Basic Machine

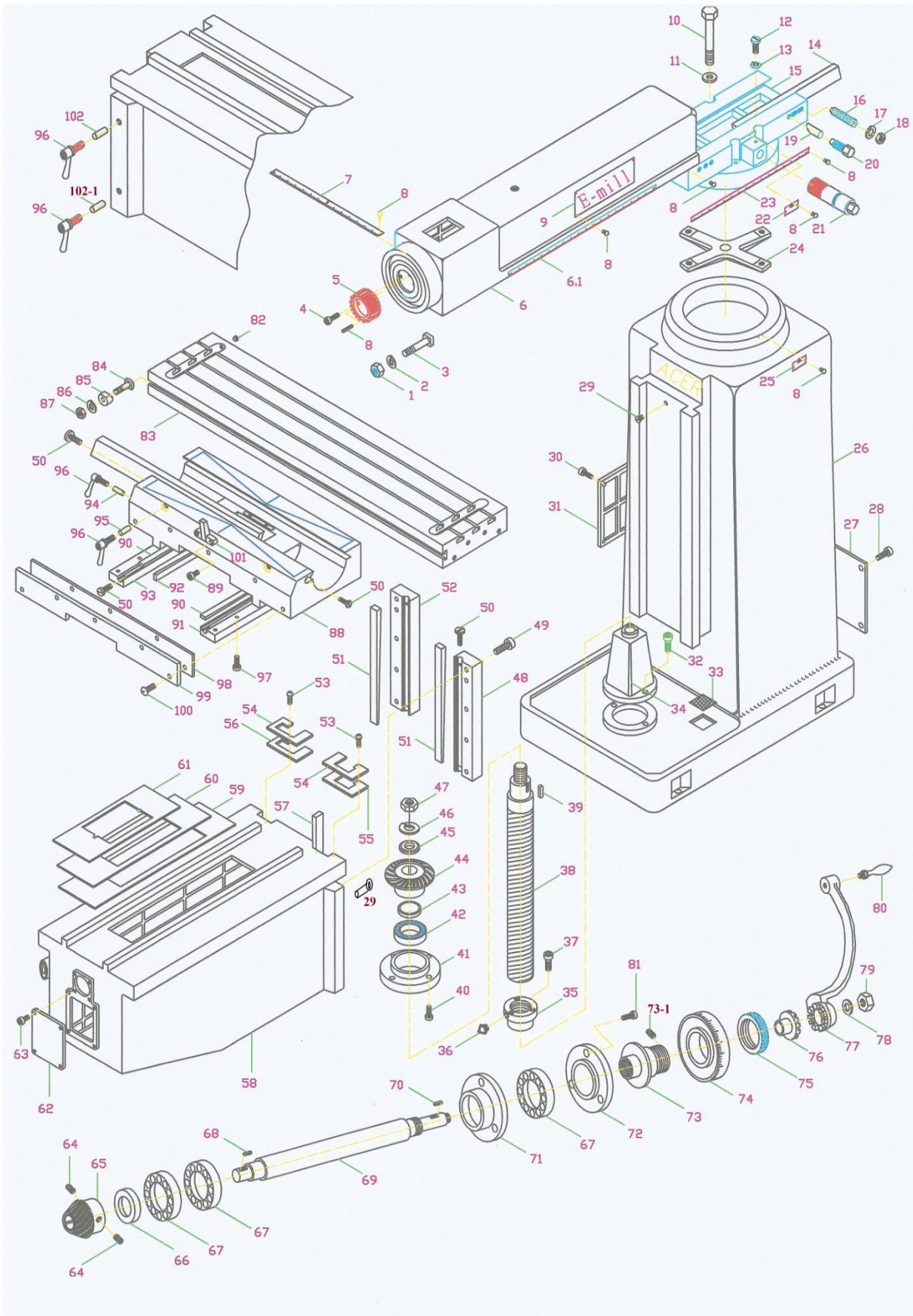

5VK Basic Machine

ITEM NO.	PART NO.	FACTOTRY NO.	DESCRIPTION	QT'Y
100	3038		Round HD + Screw 5x16mm	10
101	3035	C42	Table Stop Bracket	1
102	4H-4043	C46	Knee Lock Plunger	1
102-1	4H-4044	C46	Knee Lock Plunger	1

8-13. 6VK Basic Machine

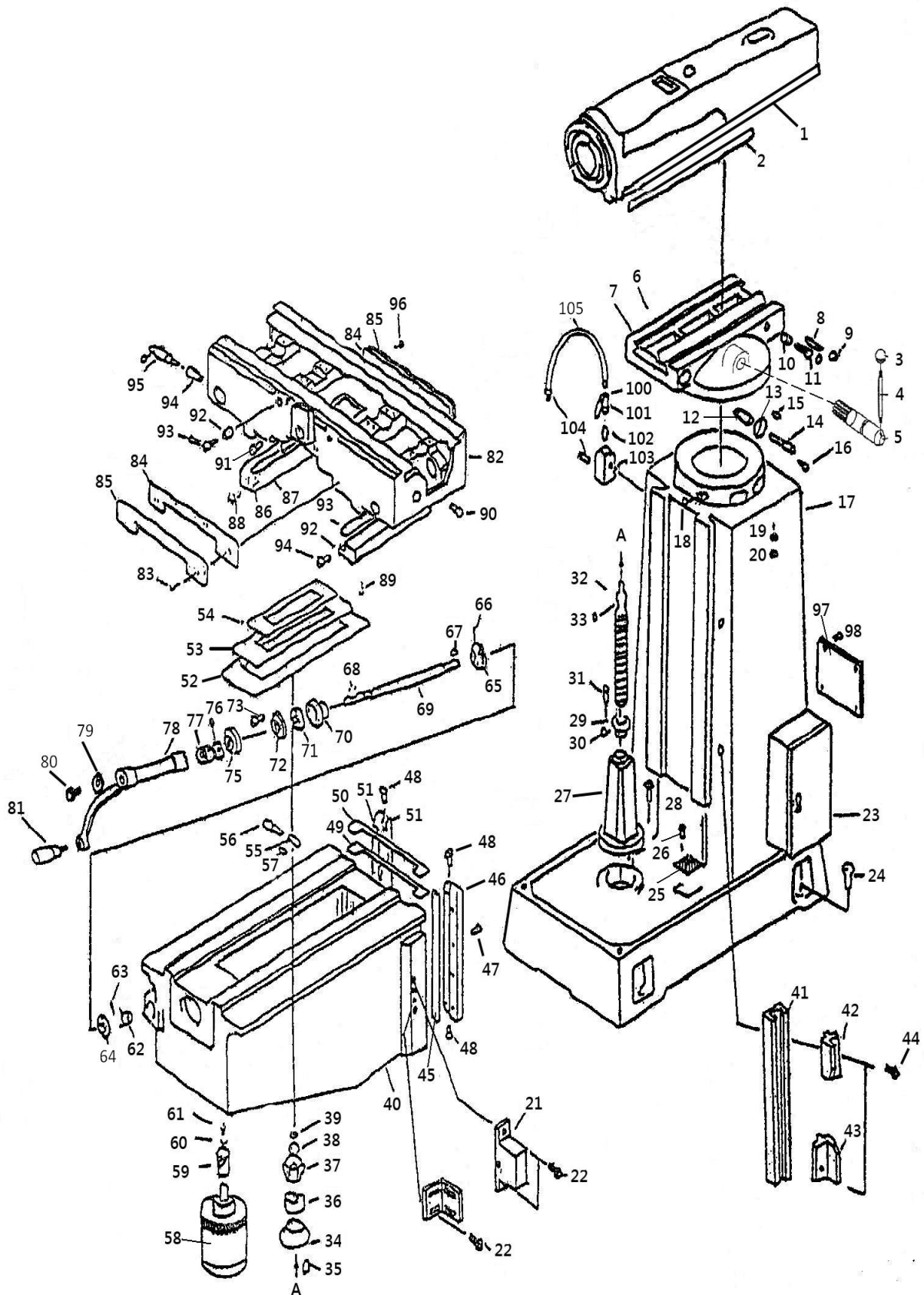

6VK Basic Machine

ITEM NO	PART NO.	FACT. NO.	DESCRIPTION	QTY
1	6K-5018	HD-004	RAM	1
2	6K-5044		RAM PLATE	1
3	6K-5014		PLASTIC BALL	1
4	6K-5013		RAM PINION HANDLE	1
5	6K-5012		RAM PINION	1
6	6K-5002	HD-036	RAM/TURRET GIB	1
7	6K-5001	HD-043	TURRET	1
8	6K-5007		GIB LOCK SCREW	2
9	6K-5007-1		GIB LOCK SCREW NUT	2
10	6K-5006		RAM LOCK PLUNGER	2
11	6K-5010		RAM LOCK SCREW	2
12	6K-5012-1		ROM PINION GEAR	1
13	6K-5012-2		GEAR CAP	1
14	6K-5012-3		GEAR SHAFT	1
15	6K-5012-4		KEY	1
16	6K-5012-5		CAP SCREW	3
17	6K-1001	HC-024	COLUMN	1
18	6K-1001-2		STOP SCREW	2
19	6K-1001-3		WASHER	4
20	6K-1001-4		NUT	4
21	6K-4001-1		CONNECTION BOX	1
22	6K-4001-2		SCREW	2
23	6K-9600-1		ELECTRICAL BOX	1
24	6K-1001-5		LEVELING SCREW	4
25	6K-1004	HD-031	FILTER	2
26	6K-1004-1		SCREW	4
27	6K-4026	HE-029	PEDESTAL	1
28	6K-4027		SOCKET HEAD CAP SCREW	2
29	6K-4024	HE-028A	ELEVATING SCREW NUT	1
30	6K-4024-1		GREASE NIPPLE	1
31	6K-4025		SOCKET HEAD CAP SCREW	3
32	6K-4021	HC-014	ELEVATING SCREW ASSEMBLY	1
33	6K-4020		KEY	1
34	6K-8039	HE-026	BEARING RETAINER RING	1
35	6K-8039-1		SOCKET HEAD CAP SCREW	3

6VK Basic Machine

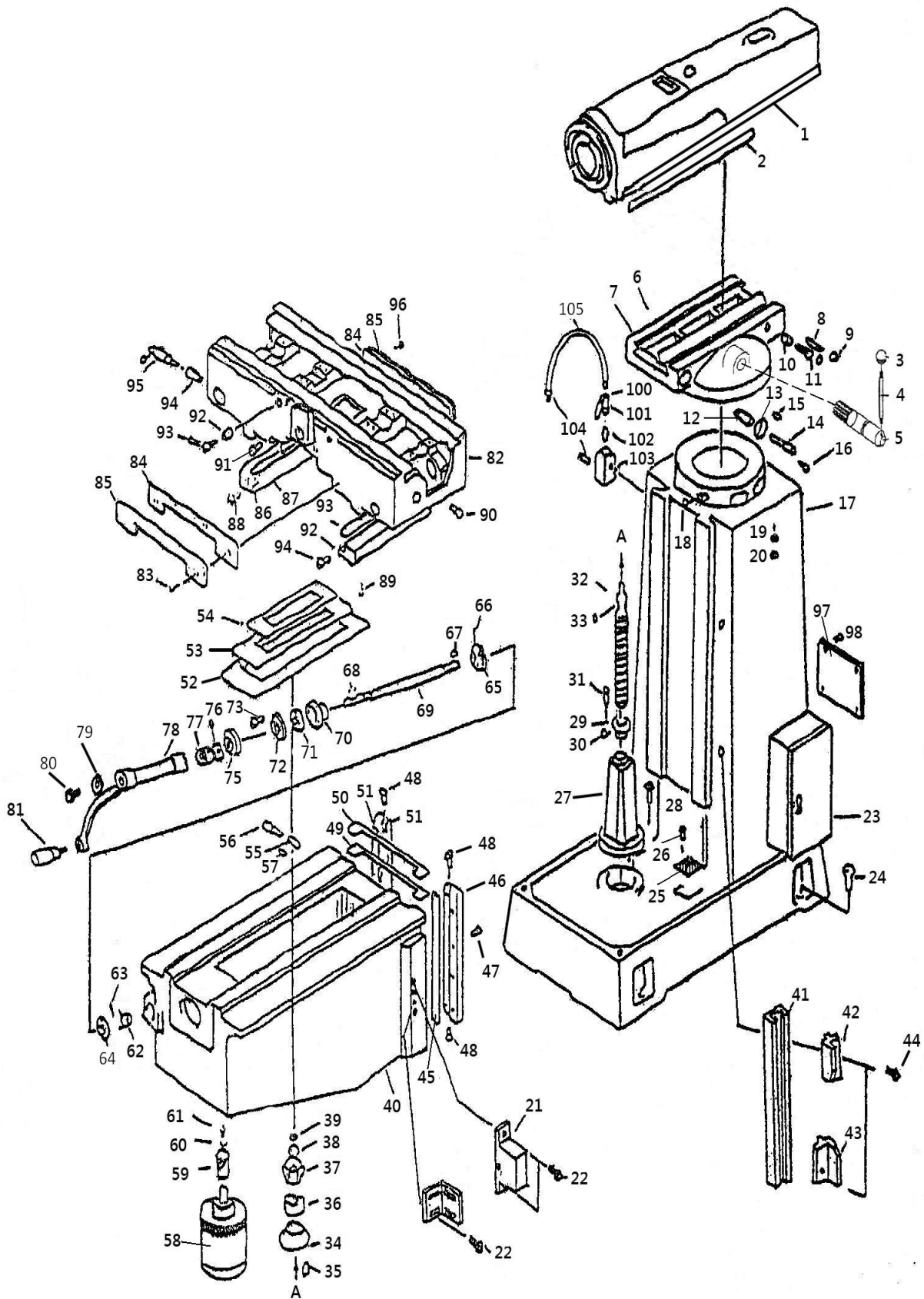

6VK Basic Machine

ITEM NO	PART NO.	FACT. NO.	DESCRIPTION	QTY
36	6K-4040		BEARING	1
37	6K-4019	HE-024	BEVEL GEAR	1
38	6K-4019-1	HC-011	WASHER	1
39	6K-4023		JAM NUT	1
40	6K-4001	HE-066	KNEE	1
41	6K-1001-6		LIMIT STOP BRACKET	1
42	6K-1001-7		STOP BLOCK	1
43	6K-1001-8		STOP BLOCK	1
44	6K-1001-9		CAP SCREW	2
45	6K-4053		KNEE/COLUMN GIB	2
46	6K-4051		KNEE/COLUMN GIB SUPPORT	1
47	6K-4052		SOCKET HEAD CAP SCREW	8
48	6K-3028		GIB ADJ. SCREW	4
49	6K-4028-1	HC-021	KNEE WIPER FELT	1
50	6K-4028-2		WIPER HOLDER	1
51	6K-4050		KNEE/COLUMN GIB SUPPORT	1
52	6K-3039		CHIP GUARDS	1
53	6K-3039-1		CHIP GUARDS	1
54	6K-3040		CHIP GUARDS	1
55	6K-3032	HC-015	SADDLE LOCK PLUNGER	2
56	6K-3030		SADDLE LOCK BOLT	2
57	6K-3030-1		SCREW	2
58	6K4001-1		ELEVATION MOTOR	1
59	6K4001-2		WORM	1
60	6K4001-3		BUSHING	1
61	6K4001-4		CAP SCREW	1
62	6K-4014	HE-015	BEVEL GEAR	1
63	6K-4014-1		SET SCREW	1
64	6K-4007		BEARING	1
65	6K-4014-1		WORM GEAR	1
66	6K-4014-2		SET SCREW	1
67	6K-4017-1		KEY	1
68	6K-4017-2		KEY	1
69	6K-4017	HE-017	ELEVATING SHAFT	1
70	6K-4006	HE-016	BEARING CAP	1
71	6K-4007		BEARING	1

6VK Basic Machine

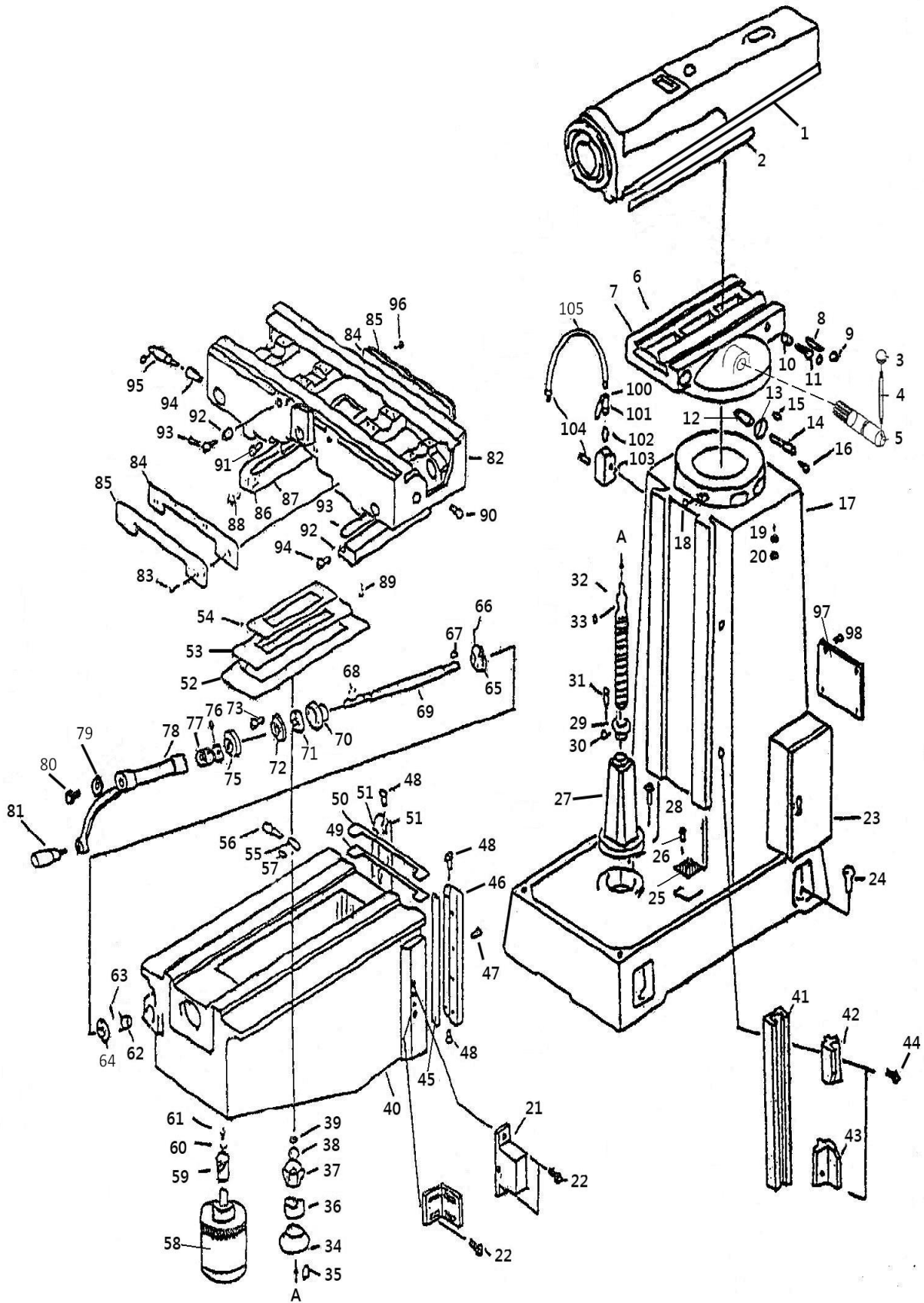

6VK Basic Machine

ITEM NO	PART NO.	FACT. NO.	DESCRIPTION	QTY
72	6K-2011	HE-015	BEARING RETAINER RING	1
73	6K-4009		SOCKET HEAD CAP SCREW	3
74	6K-4011	HE-018	DIAL HOLDER	1
75	6K-4010	HE-019	DIAL WITH 100 GRADUATIONS	1
76	6K-4011-1		SET SCRW	1
77	6K-4013	HE-020	GEAR SHAFT CLUTCH INSERT	1
78	6K-4002	HE-021	ELEVATING CRANK	1
79	6K-4004		WASHER	1
80	6K-4005		SOCKET HEAD CAP SCREW	1
81	6K-4003	HC-053	HANDLE	1
82	6K-3001	HC-017	SADDLE	4
83	6K-3038		CAP SCREW	2
84	6K-3037		FELT WIPER	2
85	6K-3037-1		SADDLE KNEE WIPER HOLDER	2
86	6K-3027-1		GIB	2
87	6K-3050		SADDLE GIB SUPPORT	4
88	6K-3028		GIB ADJ. SCREW	6
89	6K-3052		SOCKET HEAD CAP SCREW	8
90	6K-3028		GIB ADJ. SCREW	2
91	6K-3028		GIB ADJ. SCREW	2
92	6K-3029	HC-014	TABLE LOCK PLUNGER	2
93	6K-3030	HA-125	TABLE LOCK BOLT & HANDLE	2
94	6K-3032	HC-015	SADDLE LOCK PLUNGER	2
95	6K-3031		SADDLE LOCK BOLT & HANDLE	2
96	6K-3038		CAP SCREW	4
97	6K-1002		COLUMN COVER	1
98	6K-1003		CAP SCREW	4
99	6K-3035		TABLE STOP BRACKET	1
100	6K-6100		COOLANT VALVE	1
101	6K-6101		VALVE ADAPTOR	1
102	6K-6102	HD-039	TAP BRACKET	1
103	6K-6103		COOLANT ADAPTOR	1
104	6K-6103-1		SOCKET HEAD CAP SCREW	2
105	6K-6105	AD-036	COOLANT NOZZLE	1

8-14. 3VS, 3VSII, 3VK, 3VKH & 5VK Leadscrew Assembly

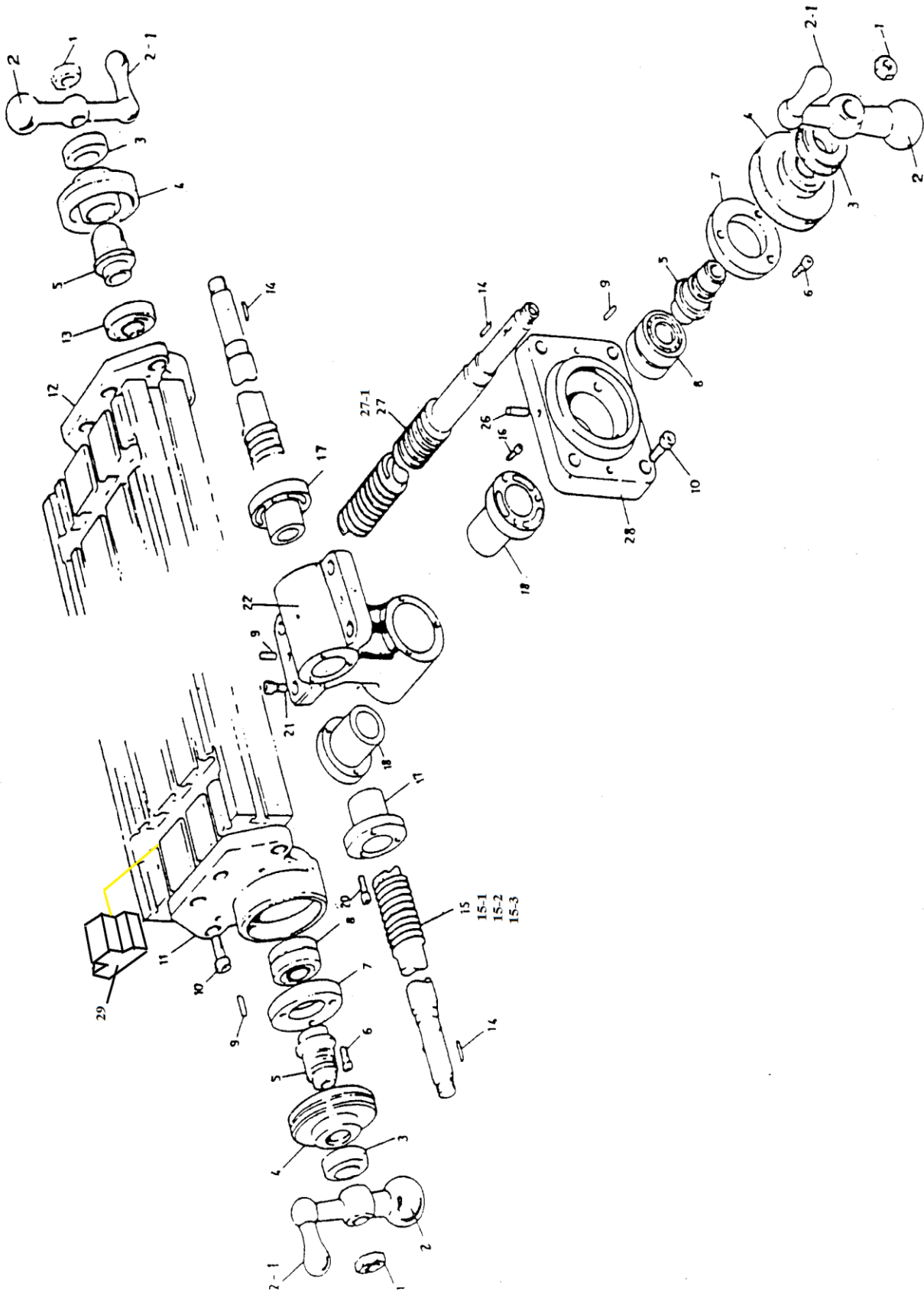

3VS, 3VSII, 3VK, 3VKH & 5VK Leadscrew Assembly

ITEM NO.	PART NO.	FACTORY NO.	DESCRIPTION	QT'Y
1	2004		Jam Nut 1/2NF	3
2	2018	D26	Ball Crank Handle	3
2-1	2018-1	C83	Ball Crank Handle Grip	3
3	2016	D3	Dial Lock Nut	3
4	2012	D4-2	Dial with 200 Graduation	3
5	2014	D5	Dial Holder	3
6	2036		Socket HD Cap Screw	9
7	2011	C90	Bearing Retaining Ring	2
8	2008		Grease Sealed Ball Bearing 6024	2
10	2026		Socket HD Cap Screw	12
11	2006	D11	Left Bearing Bracket	1
12	2006	D12	Right Bearing Bracket	1
13	2008		Grease Sealed Ball Bearing 6024	1
14	2003		Key	3
15	2002	D15	Longitudinal Feed Screw 42"	1
15-1	2002	D15	Longitudinal Feed Screw 49"	1
15-2	2002	D15	Longitudinal Feed Screw 50"	1
15-3	2002	D15	Longitudinal Feed Screw 54"	1
16	3021		Socket HD Cap Screw	5
17	3020-1		Long Feed Nut (One Set)	1
18	3020-2		Cross Feed Nut (One Set)	1
20	3021		Fixed Socket Screw	5
21	3024	D22	Socket HD Cap Screw	4
22	3025		Feed Nut Bracket	1
26	3005-1		Stop Screw	1
27	3002		Cross Feed Screw for 12" Knee	1
27-1	3002		Cross Feed Screw for 16" Knee	1
28	3005	D28	Cross Feed Bearing Bracket	1
29	2001	D29	Table Rubber Stop for Table	6

8-15. 6VK Leadscrew Assembly

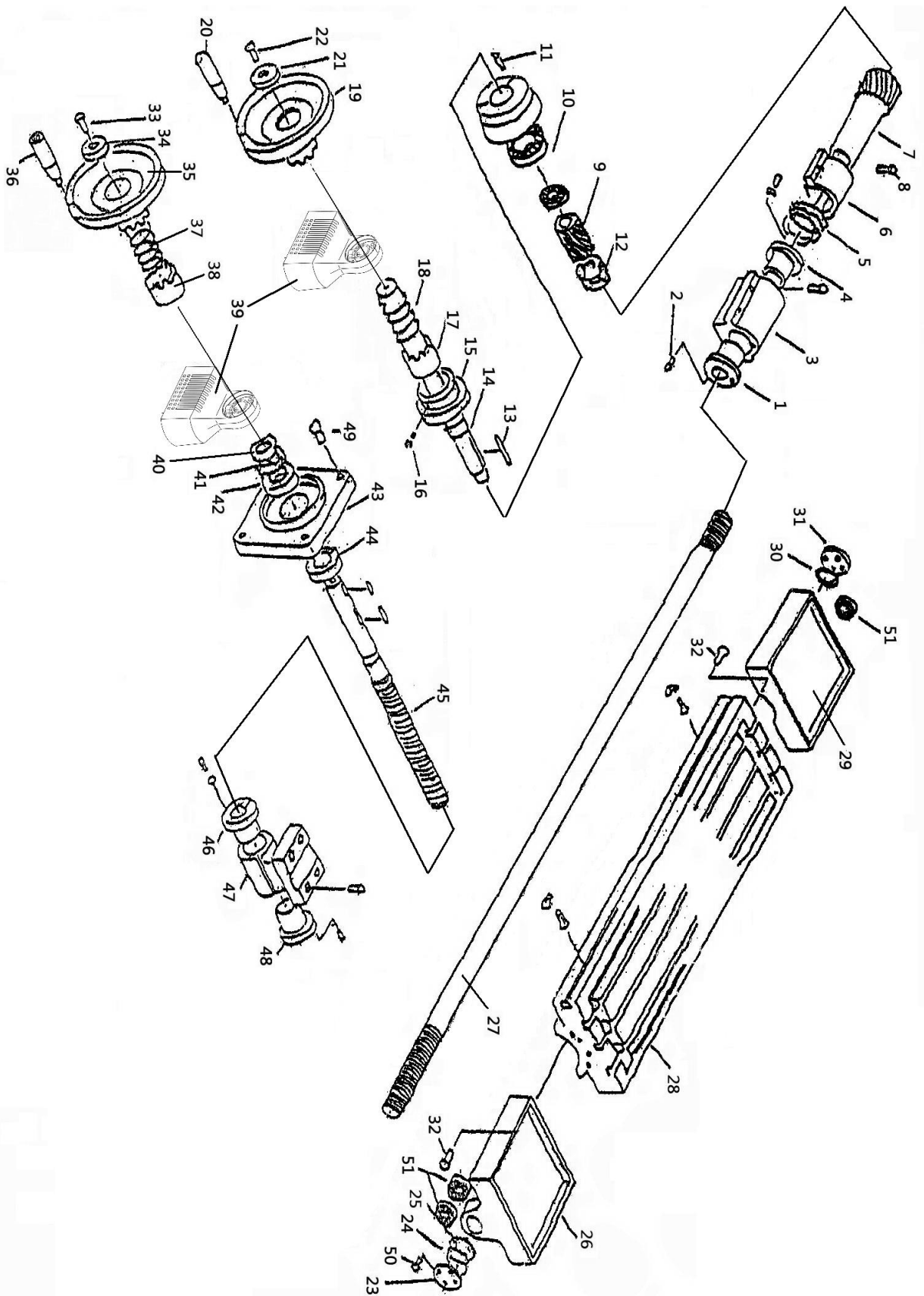

6VK Leadscrew Assembly

ITEM NO	PART NO.	FACT. NO.	DESCRIPTION	QTY
1	6K-3020-1		RIGHT LONG FEED NUT	1
2	6K-3041		CAP SCREW	3
3	6K-3025-X		GEAR BRACKET	1
4	6K-3020-2		LEFT LONG FEED NUT	1
5	6K-3020-1		LOCK WASHER	2
6	6K-6006		GEAR BRACKET	1
7	6K-6007		GEAR BUSHING	1
8	6K-6006-1		CAP SCREW	6
9	6K-6009		WORM GEAR	1
10	6K-2008		BALL BEARING	1
11	6K-2012-1		CAP SCREW	3
12	6K-6012		BEARING LOCKNUT	2
13	6K-6014-1		KEY	1
14	6K-6014		SHAFT	1
15	6K-2012		DIAL WITH 200 GRADUATIONS	1
16	6K-2012-2		SCREW	1
17	6K-2014		DIAL BUSHING	1
18	6K-6014-2		SPRING	1
19	6K-2610		HAND WHEEL	1
20	6K-2610-1		HANDLE	1
21	6K-2610-2		WASHER	1
22	6K-2610-3		CAP SCREW	1
23	6K-2002-1		SCREW COVER	1
24	6K-2016		LOCKNUT	1
25	6K-2016-1		LOCK WASHER	1
26	6K-2006-R		RIGHT SCREW BRACKET	1
27	6K-2002		LEADSCREW SHAFT	1
28	6K-2001		TABLE	1
29	6K-2006-L		LEFT SCREW BRACKET	1
30	6K-6030		SNAP RING	1
31	6K-2002-1		SCREW COVER	1
32	6K-2006-1		CAP SCREW	8
33	6K-2610-3		CAP SCREW	1
34	6K-2610-2		WASHER	1
35	6K-6210		HAND WHEEL	1

6VK Leadscrew Assembly

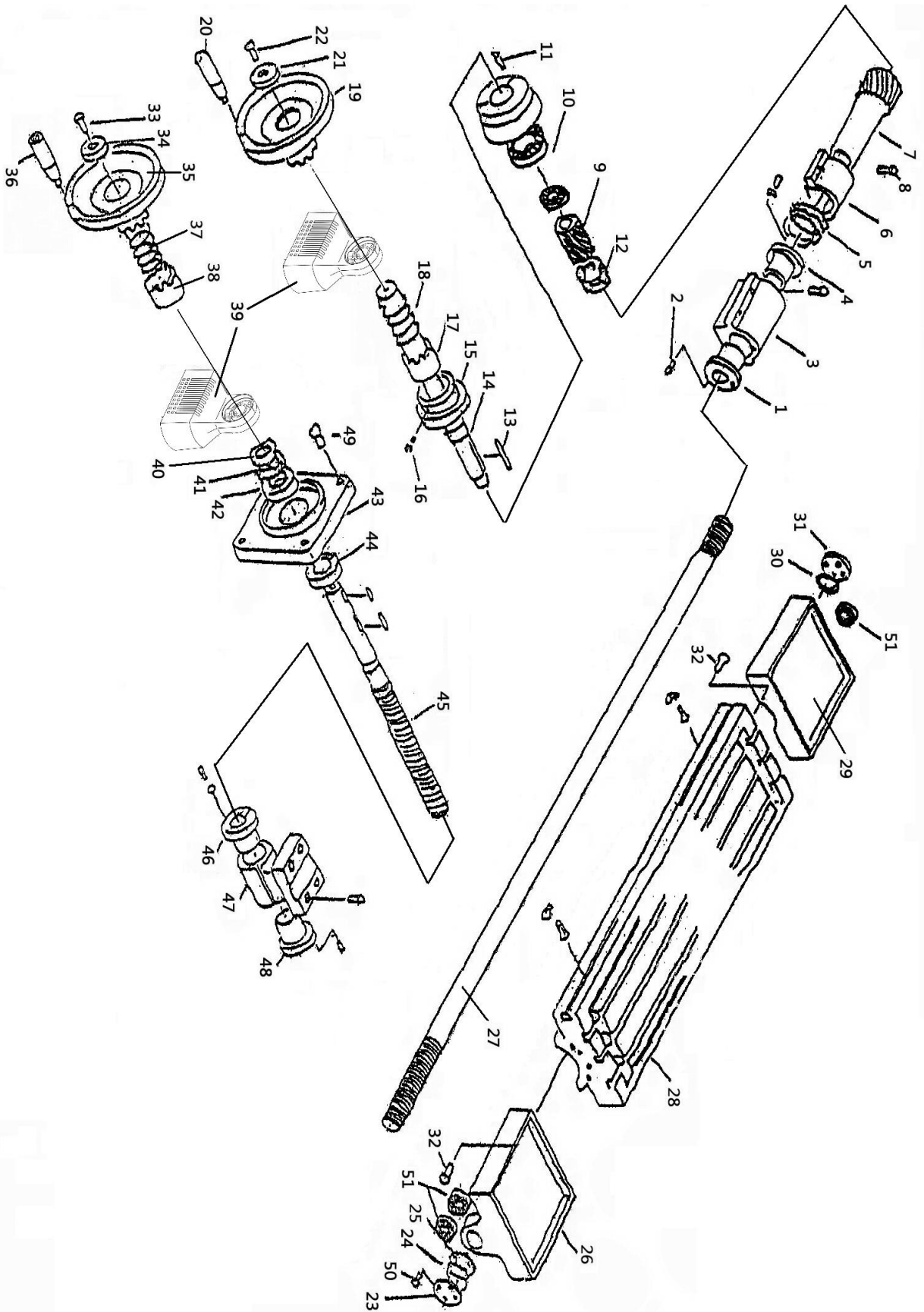

6VK Leadscrew Assembly

ITEM NO	PART NO.	FACT. NO.	DESCRIPTION	QTY
36	6K-6210-1		HANDLE	1
37	6K-6014-2		SPRING	1
38	6K-2014		DIAL BUSHING	1
39	6K-6039		POWER TABLE FEED	2
40	6K-2016		LOCKNUT	1
41	6K-2016-1		LOCK WASHER	1
42	6K-2008		BALL BEARING	1
43	6K-3005		CROSSFEED BEARING BRACKET	1
44	6K-2008		BALL BEARING	1
45	6K-3002		CROSSFEED LEADSCREW	1
46	6K-3020-3		FRONT CROSSFEED NUT	1
47	6K-3025-Y		SCREW BARCKET	1
48	6K-3020-4		BACK CROSSFEED NUT	1
49	6K-2026		SOCKET HEAD CAP SCREW	4
50	6K-2036		CAP SCREW	8
51	6K-2008		BEARING	3

8-16. Electric Cabinet

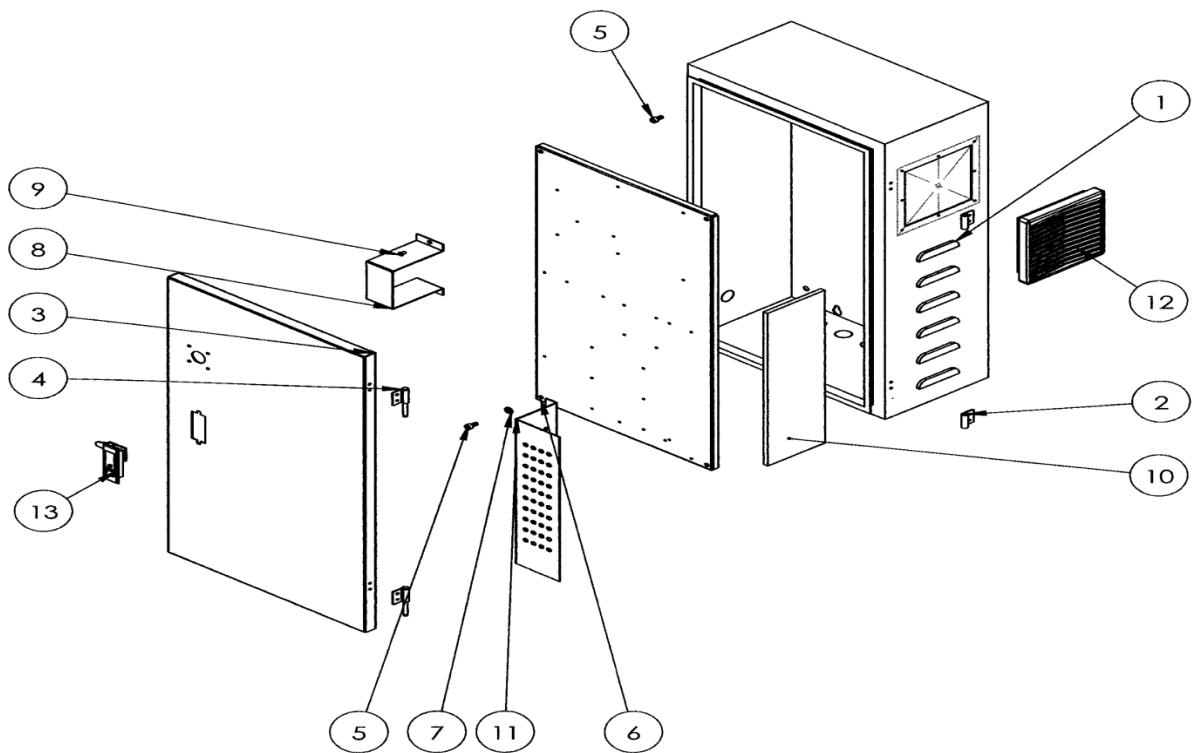

ITEM NO.	PART NO.	FACTORY NO.	DESCRIPTION	QTY
1	3V-B001		Electric Cabinet UL	1
	9600-1		Electric Cabinet	1
2	9750-A		Door Hinge Female	2
3	3V-B002		Main Cabinet Cover UL	1
	9619-1		Main Cabinet Cover	1
4	9750-B		Door Hinge Male	2
5		M6x1x12	Socket HD Cap Screw	2
6	3V-B003		Inverter Locating Plate UL	1
	9602-1		Inverter Locating Plate	1
7		M6 Narrow	Plain Washer	2
8	3V-B004		Power Switch Locating Bracket	1
9		M4x0.7x8	Round + HD Cap Screw	2
10	9751		Filter	1
11	3V-B005		Resistor Cover	1
12	9752		Fan Filter UL	1
	9634-1		Fan Filter	1
13	9620-1		Door Lock with Key UL	1
	9620		Cabinet Lock	1

8-17. Safety Accessories for All Models

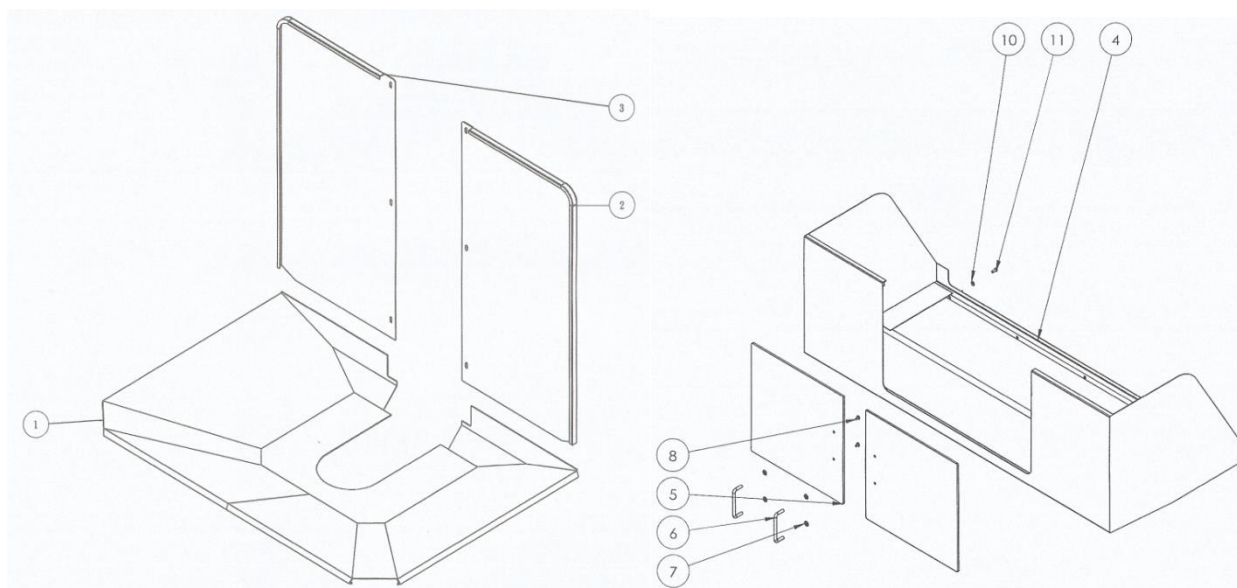

ITEM NO.	PART NO.	DESCRIPTION	QT'Y
1	9753	Chip Pan for 3VS, 3VK	1
	9753-1	Chip Pan for 3VKH, 5VK	
2	9754	Column Guard-Right	1
3	9755	Column Guard-Left	1
4	ACU-F06A_1050	Table Guard for 50" Table	1
	ACU-F06A_1054	Table Guard for 54" Table	1
	ACU-F06A_942	Table Guard for 42" Table	1
	ACU-F06A_949	Table Guard for 49" Table	1
5	ACU-F08A_1050	PVC Door for 50" Table	2
	ACU-F08A_1054	PVC Door for 54" Table	2
	ACU-F08A_942	PVC Door for 42" Table	2
	ACU-F08A_949	PVC Door for 49" Table	2
6	A-42-C	Door Handle	2
7		Washer	4
8		Round HD + Cap Screw	4
10		Plain Washer 6mm	13
11		Round HD Cap Screw	13