



S20A

393313

THANK YOU,

On behalf of everyone at HYDMECH, we would like to thank and congratulate you on your decision to purchase a HYDMECH bandsaw.

Your new machine is now ready to play a key role in increasing the efficiency of your operation, helping you to reduce cost while boosting quality and productivity.

To ensure you are maximizing the power and versatility of your new HYDMECH bandsaw, please take the time to familiarize yourself and your employees with the correct operation and maintenance procedures as outlined in this manual. Please keep this instruction manual for future reference in a known location and easily accessible to all users of the device.

HYDMECH offers a great variety of options, components, and features for its various models. Therefore, some of the equipment described in this manual (various illustrations and drawings) may not be applicable to your particular machine.

The information and specifications provided in this manual were accurate at the time of printing. HYDMECH reserves the right to discontinue or change specifications or design at any time without notice and without incurring any obligation.

Thank you.

HYDMECH CANADA Corp.
P.O. Box 1659, 1079 Parkinson Road
Woodstock, Ontario, N4S 0A9
Phone : (519) 539-6341
Service : 1-877-237-0914
Sales : 1-877-276-SAWS (7297)
Fax : (519) 539-5126
e-mail : info@hydmech.com

TABLE OF CONTENTS

SECTION 0 - SAFETY INSTRUCTIONS

SUMMARY	0.1
BASIC RULES.....	0.4
RESPONSIBILITIES OF THE OWNER.....	0.5
RESPONSIBILITIES OF THE OPERATOR AND MAINTENANCE PERSONNEL.....	0.6
SAFETY HAZARD LABELS	0.8

SECTION 1 - INSTALLATION

SAFETY PRECAUTIONS.....	1.1
LIFTING THE S20A WITH A FORK LIFT	1.2
FOUNDATION, LEVELLING AND ANCHORING	1.3
EARTH GROUNDING PROCEDURE	1.3
POWER WIRING CONNECTIONS.....	1.4
HYDRAULIC OIL.....	1.4
CUTTING FLUID	1.4

SECTION 2 - OPERATING INSTRUCTIONS

OPERATOR CONTROL PANEL.....	2.1
START-UP	2.1
CONTROL CONSOLE	2.2
HYDRAULIC FEED CONTROL.....	2.2
STARTING THE MACHINE.....	2.8
MAKE A CUT IN MANUAL MODE.....	2.9
EXECUTE A SINGLE JOB IN AUTOMATIC MODE	2.10
EXECUTE A QUEUE OF JOBS IN AUTOMATIC MODE	2.11
HYDRAULIC FEED CONTROL.....	2.13
CUTTING PARAMETERS CHART.....	2.14

SECTION 3 – MAINTENANCE & TROUBLESHOOTING

SAFETY DURING MAINTENANCE AND TROUBLESHOOTING.....	3.1
LOCK OUT PROCEDURE	3.1
BLADE CHANGING PROCEDURE	3.3
BLADE TRACKING ADJUSTMENT	3.5
DRIVE WHEEL ADJUSTMENT	3.6
BLADE GUIDE ADJUSTMENT	3.6
CARBIDE REPLACEMENT.....	3.7
BLADE BRUSH ADJUSTMENT	3.7
ANGLE BRAKE ADJUSTMENT	3.8
BLADE TENSION SLIDE ADJUSTMENT	3.9
90 AND 30 DEGREE STOP ADJUSTMENT	3.9
LUBRICATION.....	3.10
GEARBOX LUBRICATION.....	3.10
HYDRAULIC MAINTENANCE.....	3.11

SECTION 3 – MAINTENANCE & TROUBLESHOOTING

TROUBLESHOOTING	3.12
MACHINE ALARMS	3.13
WARNINGS.....	3.13

SECTION 4 - ELECTRICAL

ELECTRICAL SCHEMATICS: SEE PDF ON ATTACHED USB	4.1
--	-----

SECTION 5 - HYDRAULIC

HYDRAULIC SCHEMATICS & PLUMBING DIAGRAMS: SEE PDF ON ATTACHED USB	5.1
---	-----

SECTION 6 - MECHANICAL ASSEMBLIES

MECHANICAL ASSEMBLY DRAWINGS & PARTS LIST: SEE PDF ON ATTACHED USB	6.1
--	-----

SECTION 7 - OPTIONS

OPTIONAL ASSEMBLY DRAWINGS: SEE PDF ON ATTACHED USB	7.1
---	-----

SECTION 8 - SPECIFICATIONS

S20A BANDSAW SPECIFICATION LIST	8.1
S20A LAYOUT DRAWING.....	8.2

SECTION 9 - WARRANTY

WARRANTY	9.1
----------------	-----

SECTION 0 - SAFETY INSTRUCTIONS

SUMMARY

All persons operating this machine must have read and understood all of the following sections of this Manual:

- Section 0 SAFETY
- Section 2 OPERATING INSTRUCTIONS

However, as a memory aid, the following is a summary of the Safety Section.

Put Safety First

Mandatory Information – What operators and maintenance people must have read and understood.

Signatures – Everyone involved with this machine must sign to confirm they have read and understood mandatory information.

Basic Rules – only use this machine when

- it is in good working order
- all safety equipment is in place and functional
- operations are in compliance with this manual
- materials are within designed specifications and are non-hazardous

Owner is responsible to

- keep Manual accessible at the machine
- ensure only reliable, fully trained personnel work with the machine
- clearly define responsibilities of all personnel working with the machine
- keep the machine in good working order

Operator and Maintenance Personnel are responsible to:

- keep all safety equipment in order, check its function at the beginning of each shift, and report any shortcomings
- shut-down machine and report any faults or malfunctions which could impair safety
- understand and obey safety hazard labels
- not to wear un-restrained long hair, loose clothing or jewelry
- wear all required personal protective equipment
- not to wear gloves within 24 inches of moving blade
- maintain a clean working area and machine
- always use Lock-out when performing maintenance or repairs.

FOREWORD

Put Safety First!

This Safety Section contains important information to help you work safely with your machine and describes the dangers inherent in our machines. Some of these dangers are obvious, while others are less evident.

It really is important to PUT SAFETY FIRST. Make it a habit to consider the hazards associated with any action BEFORE you do it. If you feel any uncertainty, stop and find a safer approach to the action. If you're still uncertain, ask for advice from your supervisor.

The SAFETY FIRST approach is particularly necessary when you do something new, or different, and most people instinctively recognize this, although impatience may still cause them to take unnecessary risks.

Danger also lurks in the routine task that we have done over and over. Here, familiarity, boredom, or tiredness may lull us into unthinking, automatic repetition. Be alert for this, and when you feel it happening, stop and take stock of your situation. Review the safety hazards associated with what you are doing. That should get your brain working again.

Certainly production is important, but if you think you're too busy to put safety first, think how much production you'll lose if you get hurt.

You owe it to yourself, your family, and your co-workers to PUT SAFETY FIRST.

Mandatory Information

All persons operating this machine must have read and understood all of the following sections of this Manual:

Section 0 SAFETY

Section 2 OPERATING INSTRUCTIONS

Personnel involved in installation and maintenance of the machine must have read and understood all sections of the manual

Persons who have difficulty reading, or for whom English is not their first language, must receive particularly thorough instruction.

Signatures

Everyone involved in operation of this machine must sign below to confirm that:

I have read and understood all parts of Section 0 – Safety, and Section 2 – Operating Instructions.

Name	Date	Signature

Everyone involved in the installation, inspection, maintenance, and repair of this machine must sign below to confirm that:

I have read and understood all parts of this Operation and Maintenance Manual.

Name	Date	Signature

BASIC RULES

Intended Use

Our machines are designed and built in line with the state of the art, and specifically in accordance with American National Standards Institute Standard B11.10 *Safety Requirements for Metal Sawing Machines*. However, all machines may endanger the safety of their users and/or third parties, and be damaged, or damage other property, if they are operated incorrectly, used beyond their specified capacity, or for purposes other than those specified in this Manual.

Exclusion of Misuse

Misuse includes, for example:

Sawing hazardous materials such as magnesium or lead

Sawing work pieces which exceed the maximum workload appearing in the Specifications

Operating the machine without all original safety equipment and guards

Liability

The machine may only be operated:

When it is in good working order, and

When the operator has read and understood the Safety and Operating Instructions Sections of the Manual, and

When all operations and procedures are in compliance with this Manual.

HYDMECH cannot accept any liability for personal injury or property damage due to operator errors or non-compliance with the Safety and Operating Instructions contained in this Manual.

RESPONSIBILITIES OF THE OWNER

Organization of work

This Operation and Maintenance Manual must always be kept near the machine so that it is accessible to all concerned.

The general, statutory and other legal regulations on accident prevention and environmental protection must also be observed, in addition to the Manual material. The operators and maintenance personnel must be instructed accordingly. This obligation also includes the handling of dangerous substances and the provision and use of personal protective equipment.

Choice and qualification of personnel

Ensure that work on the machine is only carried out by reliable persons who have been appropriately trained for such work.

Training

Everyone working on or with the machine must be duly trained with regard to the correct use of the machine, the correct use of safety equipment, the foreseeable dangers that may arise during operation of the machine, and the safety precautions to be taken.

In addition, the personnel must be instructed to check all safety devices at regular intervals.

Define responsibilities

Clearly define exactly who is responsible for operating, setting-up, servicing and repairing the machine.

Define the responsibilities of the machine operator and authorize him to refuse any instructions by third parties if they run contrary to the machine's safety.

Persons being trained on the machine may only work on or with the machine under the constant supervision of an experienced operator. Observe the minimum age limits required by law.

Condition of Machine and Workplace

Ensure that the machine and its safety equipment is kept in good working order.

Ensure that the work area is well lit, and protected from the elements, such as rain, snow, abrasive dust, and extremes of temperature.

Ensure that the machine is installed with sufficient clearance around it for the safe loading and unloading of work pieces.

RESPONSIBILITIES OF THE OPERATOR AND MAINTENANCE PERSONNEL

Safety equipment

All machines are delivered with safety equipment that must not be removed or bypassed during operation.

The correct functioning of safety equipment on the machine must be checked:

- at the start of every shift.
- after maintenance and repair work
- when starting for the first time, and after prolonged shutdowns

Emergency Stop Button (E-Stops)

Always be aware of the location of the Emergency Stop Buttons). Do not allow material or objects to block your access to an Emergency Stop.

Damage

If any changes capable of impairing safety are observed in the machine or its operation, such as damage, malfunctions, or irregularities, then appropriate steps must be taken immediately, the machine switched off, locked-out, and the fault reported to the responsible person.

Safe operation

The machine may only be operated when in good working order and when all protective equipment is in place and operational.

Keep a safe distance from all moving parts – especially the blade and vises

Stock should not be loaded onto the saw if the blade is running

Long and heavy stock should always be properly supported in front of and behind the saw.

Faults

The machine must be switched off and locked-out before starting to remedy any faults.

Safety hazard labels

Safety hazard labels, and other instructional labels on the machine must be observed. They must be clearly visible and legible at all times. If they become damaged they must be replaced.

Clothing, jewelry, protective equipment

Personnel operating or working on the machine must not wear un-restrained long hair, loose-fitting clothes and dangling jewelry.

When operating or working on the machine, always wear suitable, officially tested personal protective equipment such as safety glasses and safety boots and any other equipment required by plant regulations.

Gloves

Experience has shown that careless use of gloves around machinery is a major factor in serious hand injuries.

Gloves should not be worn when operating or adjusting the machine, except:

Wear protective gloves when handling bandsaw blades at blade changes.

Gloves may be worn when handling work pieces, only if the machine is in Manual Mode and the bandsaw blade is not running.

If the machine is running in Auto Mode, and only if the cut parts are greater than 24 inches long, it may be possible to safely wear gloves for handling the cut parts, but the wearer of the gloves must never put his hands near the blade for any reason. If the cut parts are less than 24 inches long, it is required to arrange their automatic flow into a parts bucket or other suitable arrangement to avoid the necessity to pick them off the machine by hand.

Hearing protection

Ear protection must be worn whenever necessary.

The level and duration of noise emission requiring hearing protection depends upon the national regulations in the country in which the machine is being used.

The actual level of noise emission by band sawing machines depends upon work piece size, shape and material, blade type, blade speed and feed rate.

The only practical course of action is to measure the actual noise emission levels for the type of work that is typically done. With reference to national standards, decide upon the necessary hearing protection required.

In the absence of such measurements, it is advisable for anyone exposed to long periods of moderate to loud noise to wear hearing protection. It is important to understand that hearing loss is gradual and easily goes unnoticed until it is serious and irreversible.

Workplace

A clear working area without any obstructions is essential for safe operation of the machine. The floor must be level and clean, without any build-up of chips, off-cuts, coolant, or hydraulic oil.

The workplace must be well lit, and protected from the elements, such as rain, snow, abrasive dust, and extremes of temperature

Nothing may ever be placed on, or leaned against the machine, with the obvious exception of the work piece on the table and conveyor of the machine.

Master Disconnect

Lock-out the machine before undertaking any maintenance or repair work on it. 'Lock-out' refers switching off the master electrical disconnect switch, and locking it out so that it cannot be switched on again without authorization.

On HYDMECH machines the Master Disconnect Switch will be of one of four types:

- Rotary switch mounted in electrical control cabinet door and inter-locked with door
- Rotary switch mounted on the side of electrical control cabinet.
- Lever switch mounted in separate box mounted on the machine
- Supply disconnect switch supplied by user at installation and usually wall-mounted within sight of the machine, depending upon local regulations.

In almost all jurisdictions, it is required that owners of industrial equipment establish and post lock-out procedures. Know and use the lock-out procedures of your company or organization.

Residual Risks

The machine is still not completely de-energized if an electrical cabinet door type switch is locked-out.

The line side of the disconnect switch itself remains energized.

Variable speed blade drives store dangerous voltage in their capacitors, and this requires time to dissipate. After locking out power, wait 3 minutes before beginning to work on machine electrical circuits.

If compressed air is supplied to the machine to power a mist lubrication system or other devices, it should be disconnected, and any stored air pressure released before working on the machine.

The weight of individual machine components represents stored potential energy that can be released if they fall when disconnected. Secure these components with adequate hoisting gear before disassembly.

SAFETY HAZARD LABELS

The safety hazard labels attached to your machine represent important safety information to help you avoid personal injury or death.

All supervisors, operators, and maintenance personnel must locate and understand the safety information associated with each hazard label prior to operating or servicing the machine.

The safety hazard labels shown below are located at various positions on the machine to indicate possible safety hazards. The location, and re-order part number of all the safety labels associated with this particular model of bandsaw are indicated at the end of this section of the manual. It is important to replace any safety hazard label that becomes damaged or illegible.

HAZARDOUS VOLTAGE INSIDE (Item # 391938)



Contact with high voltage may cause death or serious injury. Never perform maintenance on, or near, electrical components until the machine's electrical power source has been disconnected. Lock-out power in accordance with your company's lock-out procedures before any such maintenance. The "Stop" or "Emergency Stop" push button does not disconnect the machine's power supply. Hazardous voltage is still present in the machine's electrical circuits.

The machine's Electrical Disconnect Switch does disconnect voltage from the machine's circuits, however hazardous voltage is still present inside the main electrical cabinet, on the infeed (line) side of the main fuses. Therefore keep hands

and tools away from the infeed side of the control panel main fuses. If these fuses need to be replaced, use a fuse puller. Allow three minutes after locking-out power before opening any electrical enclosures. Your machine may be equipped with a variable frequency drive that stores high voltage within its capacitors. Three minutes will allow sufficient time for this voltage to safely discharge.

Never spray coolant directly at electrical components or cabinets.

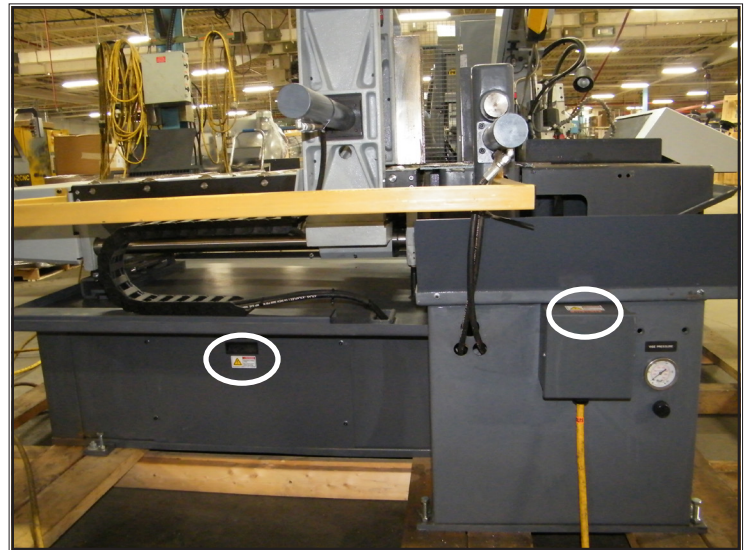

ARC FLASH HAZARD (Item #395648 and #395647 CSA)



Do not operate controls or open covers without appropriate personal protection equipment. Refer to NFPA 70E or CSA Z462 for ALL requirements.

PINCH POINT (Item # 392801)



Machine parts may move without warning because of another person initiating the motion. Keep hands clear of all labeled pinch points, whenever the machine is running. Machine vises and bundling can exert great force and cause severe injury. Keep hands clear of vises and work piece when the vises and bundling are opened or closed. Be aware that vise and bundling closing or opening may result in potentially dangerous work piece movement. Be aware also that the head swing either left or right, and the advancement or retraction of the head may create potential pinch points.



MOVING BANDSAW BLADE WILL CUT (Item #391137)

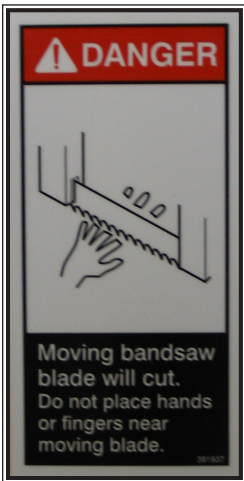

Do NOT operate with guard removed.
Do NOT place hands or fingers near moving bandsaw blade.
For blade changing, always follow the proper Blade Changing Procedure, as given in Section 3 of this manual.



DO NOT STEP (Item #391632)

Do NOT step or stand on the surface. It is stable or suitable to handle any weight. Damage will occur.



LASER (Item #391340)

Avoid direct eye or skin exposure to the direct or scattered radiation.



SECTION 1 - INSTALLATION

Upon delivery of your new bandsaw, it is imperative that a thorough inspection be undertaken to check for any damage that could have been sustained during shipping. Special attention should be paid to the electrical and hydraulic systems to check for damaged cords, hoses and fluid leaks. In the event of damage caused during shipping, contact your carrier to file a damage claim.

SAFETY PRECAUTIONS

The bandsaw has been designed to give years of reliable service. It is essential that operators be alerted to the safe operation of this saw, and the practices to avoid that could lead to injury. The following safety rules are at the minimum necessary for the safe installation, operation, and maintenance of the saw. Take every precaution for the protection of operators and maintenance personnel.

- POWER HOOK-UPS AND REPAIRS SHOULD BE ATTEMPTED ONLY BY QUALIFIED TRADESMEN.
- THE SAW SHOULD BE LOCATED IN AN AREA WITH SUFFICIENT ROOM TO SAFELY LOAD STOCK INTO THE SAW. SECURE THE SAW TO THE FLOOR.
- THE AREA AROUND THE SAW SHOULD BE MAINTAINED IN A CLEAN AND TIDY CONDITION TO AVOID OBSTACLES OPERATORS COULD TRIP OVER.
- THE BANDSAW SHOULD ONLY BE OPERATED ACCORDING TO THE SPECIFICATIONS OF THE SAW. AVOID UNSAFE USAGE PRACTICES.
- IF AT ANY TIME THE SAW DOES NOT APPEAR TO BE OPERATING PROPERLY IT SHOULD BE STOPPED IMMEDIATELY AND REPAIRED.

OPERATOR:

- THE SAW SHOULD NEVER BE OPERATED UNLESS ALL GUARDS AND DOORS ARE IN PLACE AND CLOSED.
- KEEP A SAFE DISTANCE FROM ALL MOVING PARTS - ESPECIALLY THE BLADE AND VISES.
- LOOSE CLOTHING AND GLOVES SHOULD NEVER BE WORN WHILE OPERATING THE SAW. COVER LONG HAIR.
- STOCK SHOULD NOT BE LOADED ONTO THE SAW IF THE BLADE IS RUNNING.
- LONG AND HEAVY STOCK SHOULD ALWAYS BE PROPERLY SUPPORTED IN FRONT OF AND BEHIND THE SAW.
- NEVER ATTEMPT TO DISLodge OR MOVE STOCK WHILE THE BLADE IS MOVING. TAKE THE TIME TO STOP THE SAW BLADE, REMOVE OBSTRUCTIONS, AND RESTART BLADE.
- MUST WEAR EYE PROTECTION
- MAINTAIN PROPER ADJUSTMENT OF BLADE TENSION, AND BLADE GUIDES
- HOLD WORK PIECE FIRMLY AGAINST TABLE
- DO NOT REMOVE JAMMED CUTOFF PIECES UNTIL BLADE HAS STOPPED

NO MODIFICATIONS TO THE MACHINE ARE PERMITTED WITHOUT PRIOR APPROVAL FROM HYDMECH. ANY APPROVED MODIFICATIONS SHOULD ONLY BE UNDERTAKEN BY TRAINED PERSONNEL.

LIFTING THE S20A WITH A FORK LIFT

The S20A is shrink-wrapped and shipped on a pallet. When lifting the pallet with a forklift truck make sure that the load is firmly balanced. The pallet length dimension is 110" (2794 mm). Minimum fork length of 48" (1219 mm) is recommended to safely lift the pallet.

Remove the wrapping from around the saw. Complete the inspection for signs of damage. Remove the lag bolts that hold the saw to the pallet. The larger diameter hole is used for retaining during shipping and for use with concrete floor anchors. The smaller diameter, threaded holes at each corner are used for leveling the saw properly.

The machine should be lifted from the SIDE as shown below. Locate one fork 10" and the other 38" from the front edge of the machine.

NOTE: DO NOT position the forks to allow contact with the hydraulic cabinet. DAMAGE WILL RESULT!

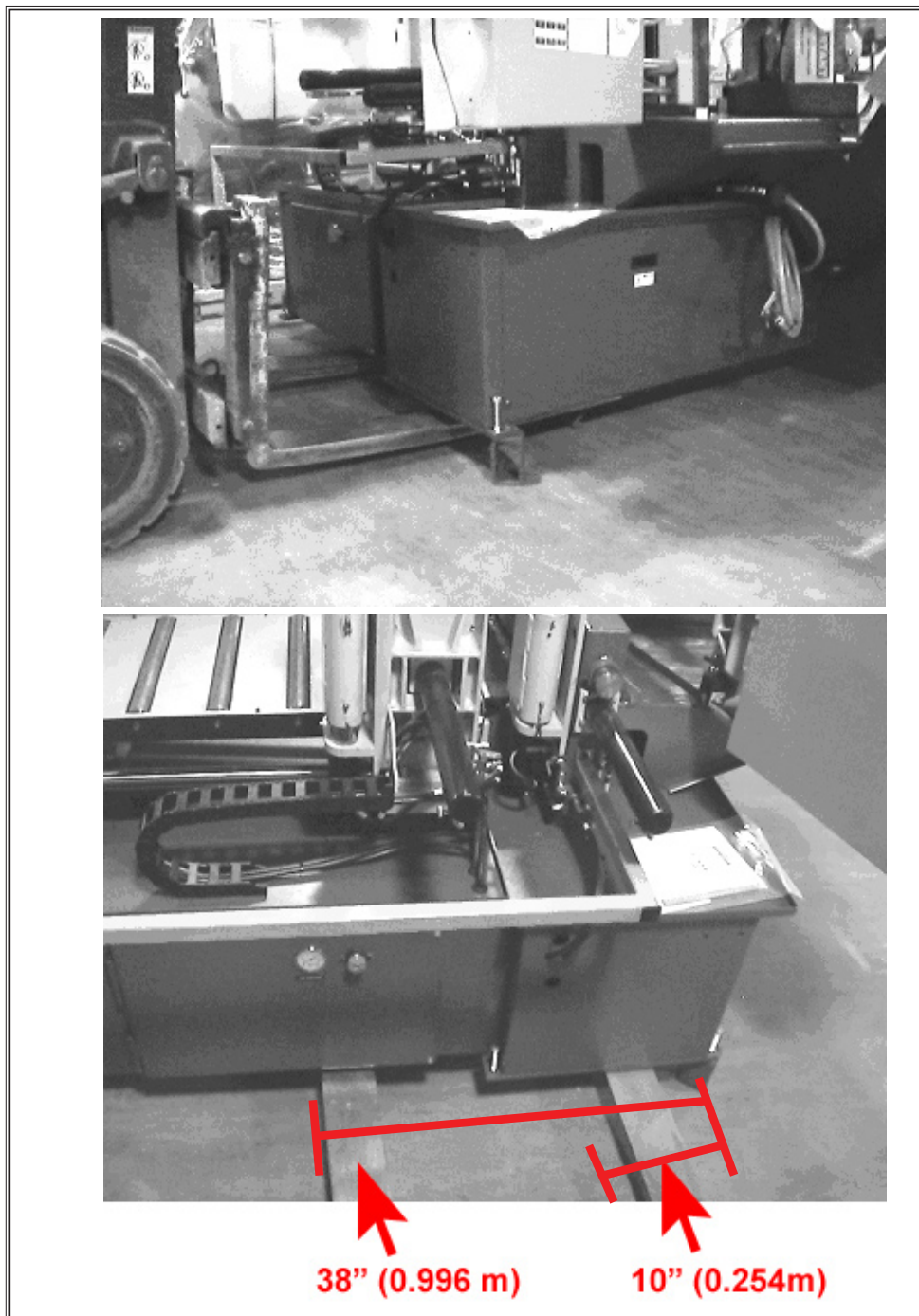

FOUNDATION, LEVELLING AND ANCHORING

Machine location should be carefully selected. A flat concrete floor area should be chosen. It should have enough free space surrounding the machine to enable free access for safe operation and maintenance. The machine should be leveled in both directions (from side to side & from front to back). Six leveling screws used for securing machine to the pallet during transport, should be installed, one in each corner of the machine base, as shown below. It might be required to place steel plates under leveling bolts to prevent their sinking into the concrete floor. In cases when the machine is to be anchored permanently, anchoring holes are provided. They are located next to the leveling screw holes. The larger diameter hole is used for retaining during shipping and for use with concrete floor anchors. The smaller diameter threaded hole at each corner, are used for leveling the saw.

Using a level on the machine out-feed table, level machine front to back and side to side.

NOTE: In some cases leveling the saw infeed with a slight slope towards the blade is recommended. This will prevent coolant from running down the raw stock. (This is especially true when cutting tubing or bundles).

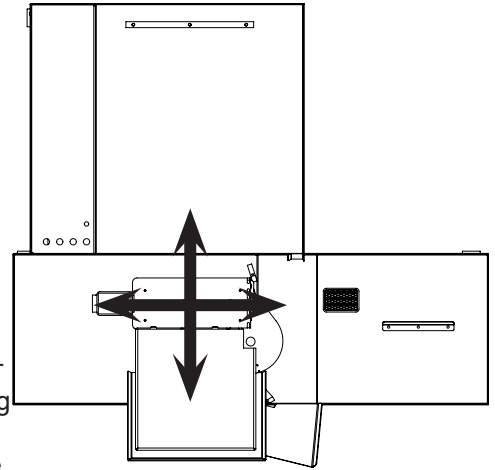

EARTH GROUNDING PROCEDURE

1. The customer is to provide and install a ground rod approximately .60 (15mm) diameter, copper clad steel, to be driven no less than 8' (2.5m) into the ground, no more than 10' (3m) away from control enclosure.
2. The ground rod is to be connected to customer's in plant ground system. This connection shall be made directly at the ground rod. (If applicable).
3. It is desirable that the overall resistance to ground measured at the ground rod does not exceed 3 ohms. Customer is advised to consult local power company for further information on grounding.
4. The ground rod is to be connected to the ground terminal in the control enclosure using insulated, stranded copper wire. The wire gauge size is to be determined according to the electrical code of the customers local electrical authority.
5. An additional point to check is to ensure continuity of all ground within the control enclosure. Start with the main power entrance ground terminal where the internal ground conductors should originate and then connect to, the DIN terminal strip, control transformer, and the lid of control enclosure. Also, the PLC and Interface units should have their own ground conductors connected to one of the main ground terminals.
6. A properly functioning ground system will:
 - provide safety for personnel.
 - ensure correct operation of electrical/electronic apparatus.
 - prevent damage to electrical/electronic apparatus.
 - help dissipate lightning strikes.
 - divert stray radio frequency (RF) energy from electronic/control equipment.

POWER WIRING CONNECTIONS

After the machine is levelled and anchored the necessary power hook-up needs to be performed. Check that there is no sign of shipping damage to the electrical conduits, cords or hydraulic hoses.

As supplied, the machine is set to run on three phase voltage as indicated on the serial plate and voltage label. Machine voltage is customer specific and should be indicated while ordering the machine. If machine voltage does not match available power source, contact the factory.

Power connection to the machine is made in the junction box, located on the idler side of the machine base. The power cable can be routed through the supplied hole in the junction box (ensure correct strain relief is used) and connections made to terminals L1, L2, L3 and ground terminals.



Power junction box without auto-transformer installed in the bandsaw.

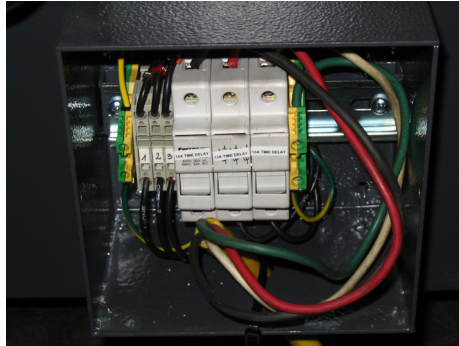

Power junction box with auto-transformer installed in the bandsaw.



Power junction box

HYDRAULIC OIL

The S20A is supplied with an AW 46 hydraulic oil. Substitutes should be of the same viscosity hydraulic oil.

CUTTING FLUID

The S20A uses a pump and reservoir to circulate the necessary cutting fluid to the blade for maximum blade life. Your saw blade supplier will be able to provide information to the cutting fluid products that are available for your needs.

No cutting fluid (coolant) is supplied with the machine. There are two types of coolant available:

- Oil based; dilute 1:10 ratio (one part concentrated coolant to 10 parts water)
- Synthetic; dilute as recommended by manufacturer.

SECTION 2 - OPERATING INSTRUCTIONS

OPERATOR CONTROL PANEL

The operator control panel provides the operator with all the controls necessary to operate the saw after the cutting angle has been set and the stock has been loaded and secured. All of the electrical functions are operated from the control panel. **For all the functions to work the machine has to be powered up.** The Main Disconnect switch, which is located on the side of control box, has to be in ON (1) position. Emergency Switch has to be released (Rotate Emergency button 45° to release). For the blade to operate the blade guard door has to be completely shut and blade tensioned to the correct setting:

Minimum tension 2200 lbs. (1000 kg) Maximum tension 2650 lbs. (1200 kg)

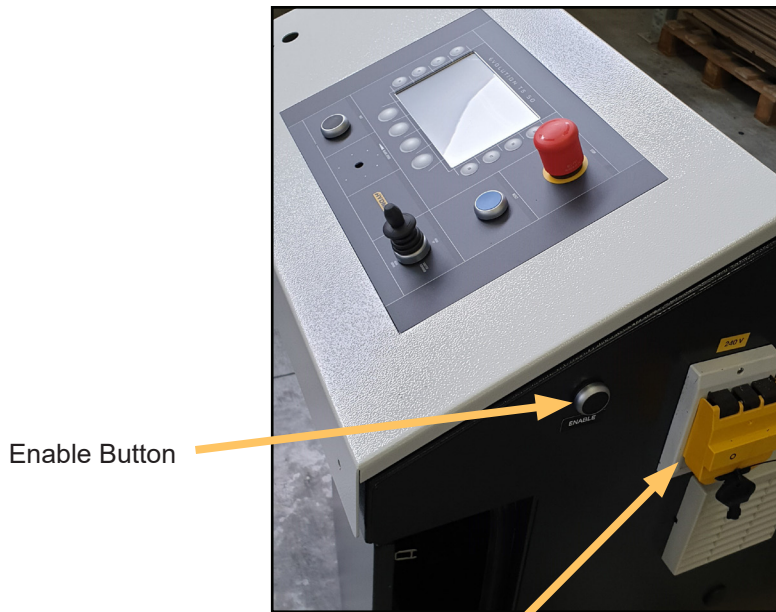

Machine Disconnect Switch

The Machine Disconnect Switch is located on the side of the machine control box. It is a **Thermal-magnetic circuit breaker with under voltage coil and door locking device**. The switch consists of three power failure protection systems. In the event of a power failure, this switch disconnects all the electrical devices, causing the machine to immediately shut down and prevents it from automatically starting when power is restored. This device also resets the thermal relay fitted to protect against current overloads.

START-UP

We can not overstate the importance of familiarizing yourself with the controls of the bandsaw prior to starting the machine for the first time.

NOTE: WHEN STARTING THE BANDSAW FOR THE FIRST TIME MAKE SURE THAT THE PRESSURE IS 440 PSI (30 BAR) AND THAT THE BLADE IS RUNNING IN A COUNTER CLOCKWISE DIRECTION AS VIEWED FROM THE OPERATOR CONSOLE.

CONTROL CONSOLE

The control console is arrayed with a complete set of controls to operate the electrical and hydraulic functions of the saw. The HMI (Human Machine Interface) consists of all, the electrical controls required to function the saw.



HYDRAULIC FEED CONTROL

The hydraulic feed controls are located on the left side of the control console and consist of the Feed Force Setting knob, the Feed Rate knob and the Head Fast Approach lever. These controls allow the operator to control both the Feed Force Limit and the Feed Rate. See Cutting Parameters Chart information on the following pages.



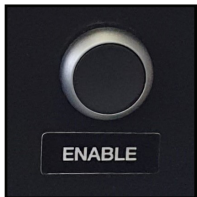
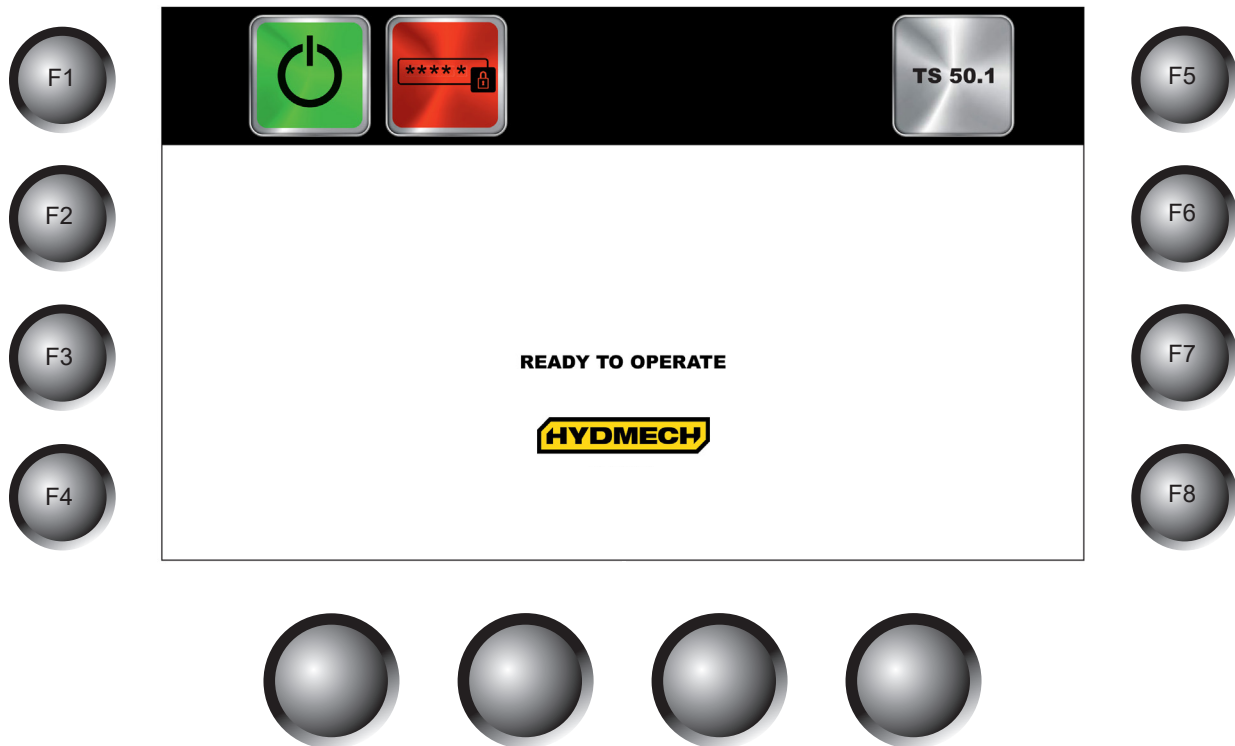

ENABLE:

- This button must be simultaneously pushed and held with the VISE OPEN or CLOSE buttons in order for the vise to move.
- If either the ENABLE button or the VISE OPEN or CLOSE buttons are released, the vise will stop moving.



EMERGENCY STOP:

- This button will stop both the hydraulic and blade motors. The head motion will cease. The vises remain as they are, but if closed, they will lose gripping force. For this reason all long stock should be supported so that it will not fall.
- To reset the button, simply rotate through 45°.



RESET:

- This is used at the initialization phase after the “ON” button (machine start) is depressed and to RESET any alarm conditions that may occur.

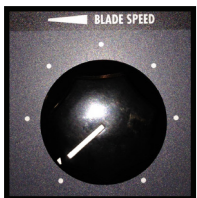

BLADE SPEED DIAL:

- This dial controls the blade speed which can be adjusted to the desired speed in SFM or SMM . The blade speed is displayed on the LCD as “S”.

SHUTTLE HOME

SHUTTLE HOME “F5”:

- This button is used to home the shuttle. It must be used in the start up sequence of the machine.



HEAD DOWN:

- When the joystick is pulled down the head will move down until any of the following occur:
 - i) The joystick is released.
 - ii) The hydraulic cylinder is at it's minimum capacity.
- Head feed and head force are controlled by the FEED RATE and FEED FORCE controls.

HEAD UP:

- When the joystick is pushed up the head will move up until any of the following occur:
 - i) The joystick is released.
 - ii) The head up L/S is activated
 - iii) The hydraulic cylinder is extended to it's maximum capacity.

SHUTTLE FORWARD:

- When the joystick is pushed to the right in MANUAL MODE the shuttle will travel towards the saw blade and will stop and hold its position when the joystick is released.
- If SHUTTLE HOME is not executed each time the machine is started then SHUTTLE FORWARD will not function

SHUTTLE REVERSE:

- When the joystick is pushed to the left in MANUAL MODE the shuttle will travel away from the saw blade and will stop and hold its position when the joystick is released.
- If SHUTTLE HOME is not executed each time the machine is started then SHUTTLE REVERSE will not function.



FAST:

- Pressing and holding this button prior to moving the joystick to SHUTTLE FORWARD or SHUTTLE REVERSE will allow the shuttle to move in FAST mode.



MANUAL MODE: To start the machine in manual mode:

- When "Ready to Operate" is displayed press the "ON" button on the touchscreen.
- Press the "Reset Button". The head will move to the upper L/S to activate the switch.
- Press F5 to Home the shuttle.

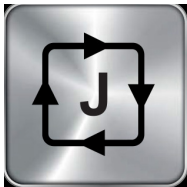

AUTOMATIC MODE:

- To enter Automatic mode the "Manual Mode" symbol on the touchscreen must be pressed. The symbol will change.
- The Front Vise must be closed for the AUTO MODE cycle to start.



AUTOMATIC QUEUE MODE:

- To enter Automatic Queue Mode the "Automatic Mode" symbol on the touchscreen must be pressed. The symbol will change.
- The Front Vise must be closed for the AUTO MODE cycle to start.



FRONT VISE OPEN:

- To open the front vise, simultaneously press the ENABLE and FRONT VISE OPEN push buttons.
- When both buttons are depressed and held, the front vise will open all the way. The vise will stop if either of the buttons are released.
- The pictogram will be green in colour when front vise open is selected.



FRONT VISE CLOSE:

- To close the front vise, simultaneously press the ENABLE and FRONT VISE CLOSE push buttons.
- When both buttons are depressed and held, the front vise will close all the way to the fixed jaw or until it encounters enough resistance to stop it. The vise will stop if either of the buttons are released.
- The pictogram will be green in colour when front vise close is selected.

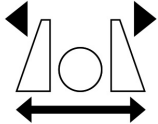

SHUTTLE VISE OPEN:

- To open the shuttle vise, simultaneously press the ENABLE and SHUTTLE VISE OPEN push buttons.
- When both buttons are depressed and held, the shuttle vise will open all the way. The vise will stop if either of the buttons are released.
- The pictogram will be green in colour when shuttle vise open is selected.



SHUTTLE VISE CLOSE:

- To close the shuttle vise, simultaneously press the ENABLE and SHUTTLE VISE CLOSE push buttons.
- When both buttons are depressed and held, the shuttle vise will close all the way to the fixed jaw or until it encounters enough resistance to stop it. The vise will stop if either of the buttons are released.
- The pictogram will be green in colour when shuttle vise close is selected.



ON (Machine Start):

- This button on the touchscreen is used on initial start up when “Ready to Operate” is displayed.

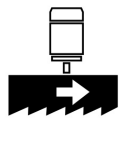

BLADE ENABLE “F6”:

- This button is used to enable the blade.
- The blade will not start if the head is completely in the down position or if the HEAD DOWN LIMIT setting has been reached.



START

BLADE/CYCLE START “F7”:

- This button is used to initiate BLADE & CYCLE START in manual and automatic mode.



STOP

STOP “F8”:

- This button is used to stop the blade.
- A lit LED will be visible when the blade is OFF. It is also used to interrupt an auto cycle program.

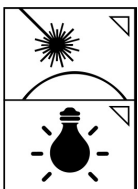

WORK LIGHT/LASER “F1”:

- Press F1 continuously until desired light, laser, or both are turned on.
- The pictogram will be changed to green when selected.



COOLANT "F2":

- Press F2 continuously until desired COOLANT mode is selected. The pictogram will be changed to green when selected.

- Coolant Off (White Background) - When selected no coolant will flow.



- Coolant Manual - When selected Coolant will flow continuously.



- Coolant Automatic - When selected Coolant will flow only when the blade is running OR when the blade is running and the head is descending.



MIST OPTION "F4":

- Press F4 continuously until desired MIST mode is selected. The pictogram will be changed to green when selected.

- Mist Off (White Background) - When selected no coolant will flow.

- Mist Manual & Automatic - Blade start must be selected for the MIST to operate.

mm
—
inch

UNITS "F3":

- This button is used to change the values between metric and imperial.

**RESET
PC**

RESET PC "F5":

- This button is used to reset the number of pieces cut.

**RESET
QUEUE**

RESET QUEUE "F1":

- This button is used to reset the queue.

**RESET
TCT**

RESET TCT "F4":

- This button is used to reset the total time cut.

**RUN
PROG**

RUN PROG "F5":

- This button is used to program a sequence of jobs in Automatic Queue Mode.

**PASSWORD:**

• This button on the touchscreen is used to enter the password. When the correct password is entered then it will allow access to the machine setup, software options, and diagnostic functions of the machine.

**MACHINE SETUP:**

• This button on the touchscreen is used to access the machine parameters and calibration screens.

**DIAGNOSTIC:**

• This button on the touchscreen is used to access the diagnostic functions to troubleshoot the machine malfunctions.

**SOFTWARE OPTIONS:**

• This button on the touchscreen is used to activate the software options.

**PREVIOUS PAGE:**

• This button on the touchscreen is used to exit to the previous page.

**ALARM:**

• This button on the touchscreen will be flashing when there are alarms on the machine. Pushing this button will take you to the Alarm Screen.

**NEXT PAGE:**

• This button on the touchscreen is used to move to the next page.

**MAIN SCREEN:**

• This button on the touchscreen is used to access the main screen.

**RELOAD:**

• This button on the touchscreen is used to refresh the entered job data or parameter values.

**SAVE ICON:**

• This button on the touchscreen will save the entered data.

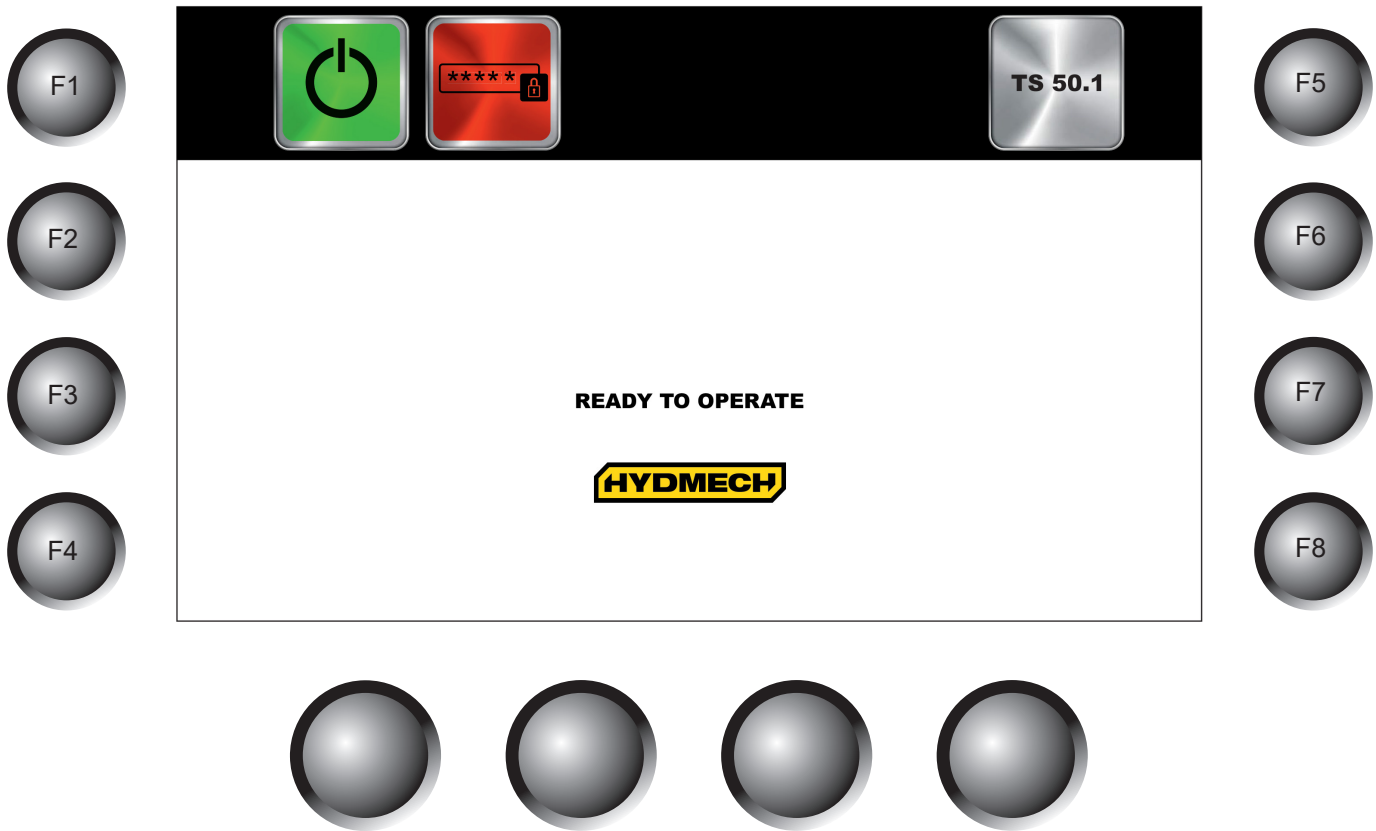

STARTING THE MACHINE

1. Turn on the machine disconnect switch to put the machine under power. Release Emergency Stop if depressed
2. When "Ready to Operate" is displayed press the "ON" button on the touch screen
3. Press "Reset Button"
4. If the head is not at the upper L/S then it will move up until the switch is activated
5. Press F5 to home the shuttle
6. You will now be in Manual Mode.



7. Pressing the Manual Mode button once will take you to Automatic Mode.



8. Pressing the Automatic Mode button once will take you to Automatic Queue Mode



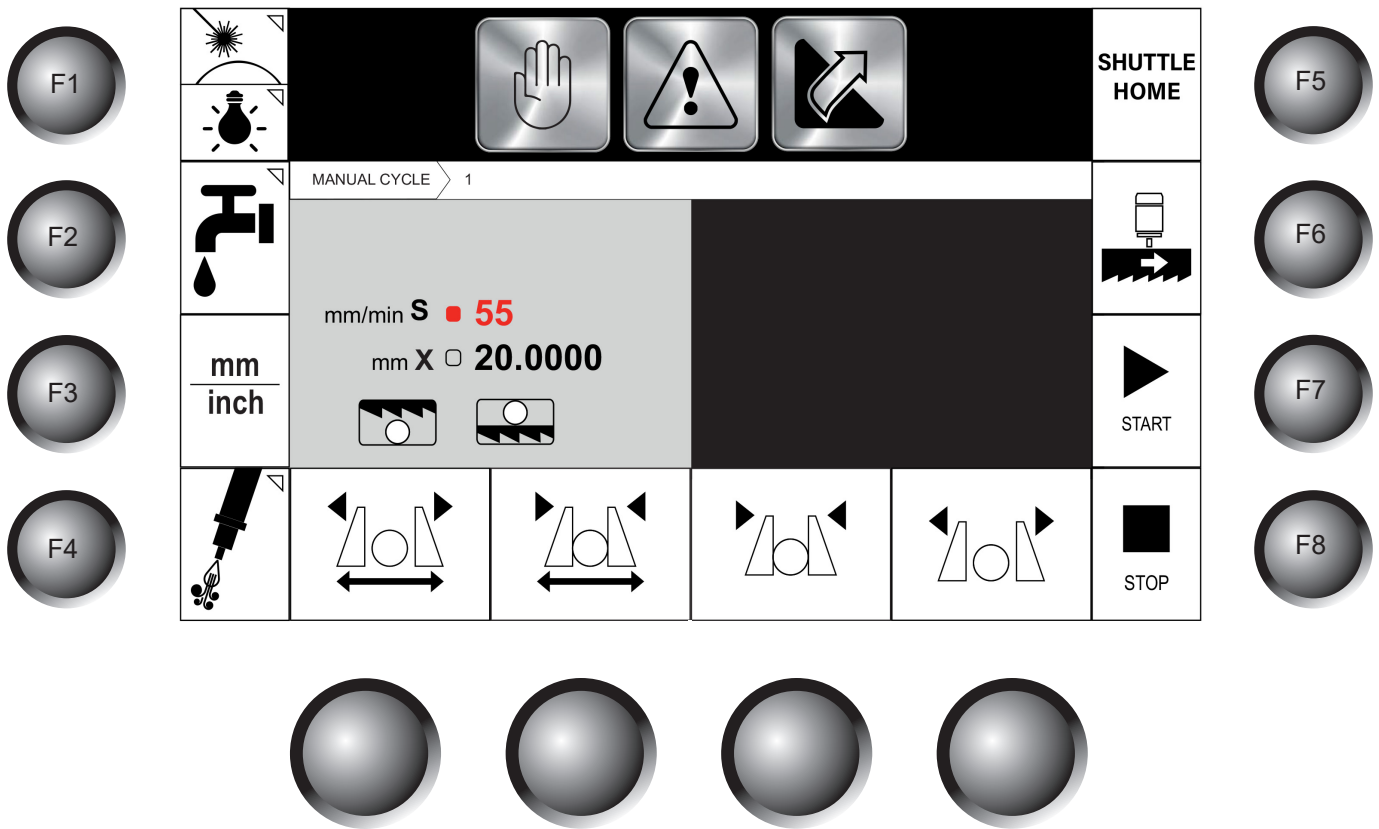

MAKE A CUT IN MANUAL MODE

1. You are now in "Manual Mode"
2. To move the shuttle by joystick, the head must be at the upper L/S. If not the head will move up until the head up L/S is activated. Then the shuttle will move in the selected direction. Shuttle fast positioning - press the "Fast" button then use the joystick.
3. Move the material to the desired length. To clamp the material - simultaneously press the enable and front vise close buttons.
Position the head by using the joystick for "Head Up" or "Head Down" and adjust the upper limit position.
4. Select Flood (F2) or Mist (F4) then "ON" or "Auto" by pressing the button continuously to cycle through the options.
5. Manually position the movable guide arm close to the work piece.
6. Set Feed Force and Feed Rate using the dials on the left of the control panel.
7. Set Blade Speed using potentiometer.
8. Press F6 to enable the blade & then press F7 to start the blade & cycle. The blade will start and head will descend with set feed rate. (Note. To start the cycle, head must be in upper position and the head up switch activated)
9. After completion of the cut the blade will turn off and the head will move up until the head up limit switch is activated.
10. To make another cut repeat steps 3 to 8.

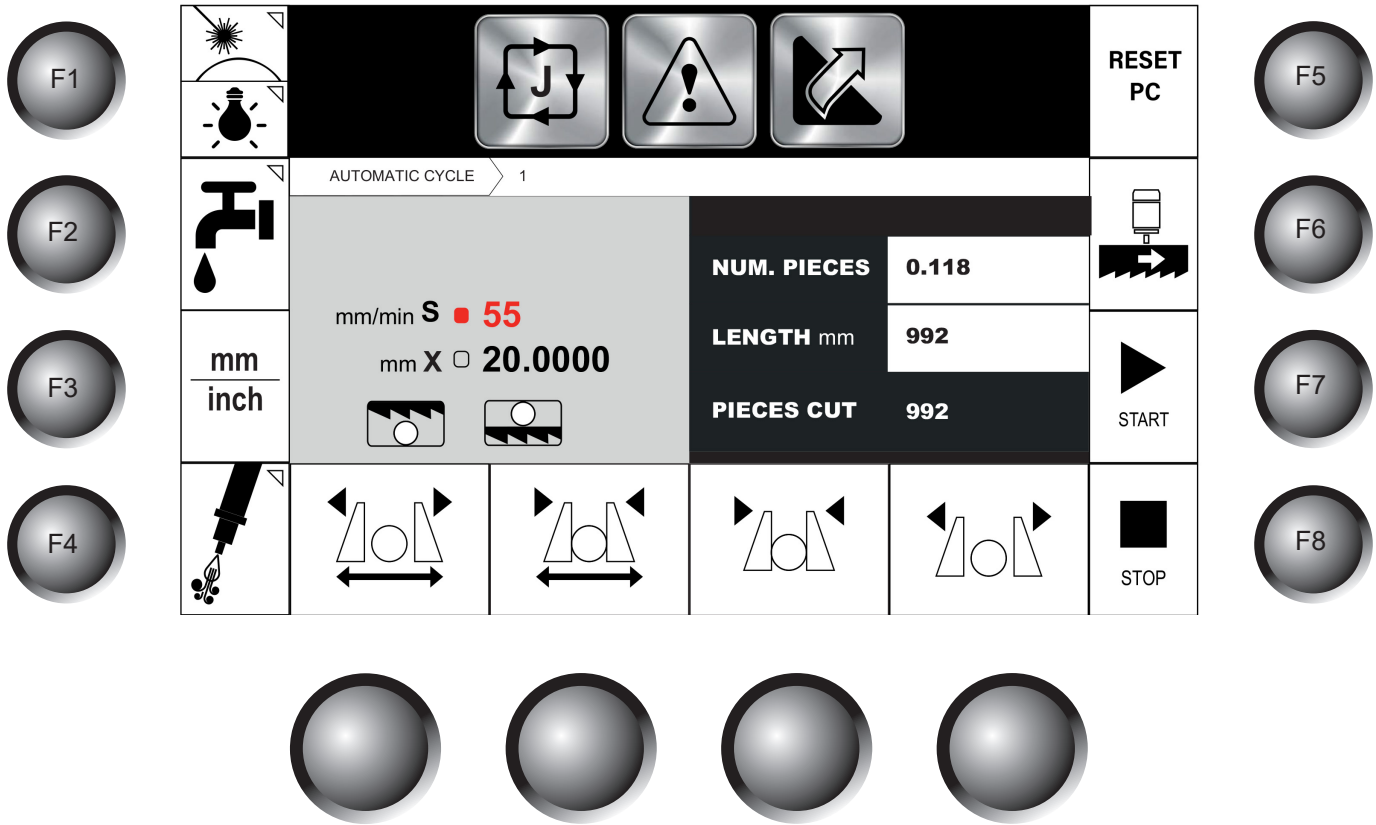

EXECUTE A SINGLE JOB IN AUTOMATIC MODE

1. Press the “Manual Mode” button on the touch screen. You are now in “Automatic Mode Single Job”

***** (Note: The Front Vise must be in the closed position in order to enter Automatic Mode) *****
2. Move the material to the desired length. To clamp the material - simultaneously press the enable and front vise close buttons.
Position the head by using the joystick for “Head Up” or “Head Down” and adjust the upper limit position.
3. Select Flood (F2) or Mist (F4) then “ON” or “Auto” by pressing the button continuously to cycle through the options
4. Tap the LENGTH entry box on the touchscreen to open the keypad.
5. Enter the required length to be cut and press the “check mark” button.
6. Tap the No. PIECES entry box on the touchscreen to open the keypad. Enter # of pieces required and press the “green check mark” button. Press F5 to reset piece counter.
7. Manually position the movable guide arm close to the workpiece.
8. Set Feed Force and Feed Rate using the dials on the left of the control panel.
9. Set Blade Speed using potentiometer.
10. Press F6 to enable the blade & then press F7 to start the blade & cycle. The blade will start and head will descend with set feed rate. Shuttle will move to programmed length and close the shuttle vise. (Note. To start the cycle, head must be in upper position and the head up switch activated)
11. After completion of the cut the blade will turn off and head will move up until the head up limit switch is activated.
12. Front vise will open and shuttle will feed programmed length.
13. Front vise will close, blade will start and head will descend with set feed rate. Shuttle will move to next programmed length.
Cycle will repeat until all required pieces are cut.
14. To interrupt auto cycle press F8 and to restart auto cycle press F7. If an interrupted cycle is restarted then it will start from the beginning of the cycle. In order to restart the head must be raised to the upper limit.
Reset can be pressed to abort the cycle.

EXECUTE A QUEUE OF JOBS IN AUTOMATIC MODE

1. Press the “Automatic Mode Single Job” button on the touchscreen. You are now in “Automatic Mode Queue”
2. Move the material to the desired length. To clamp the material - simultaneously press the enable and front vise close buttons.
Position the head by using the joystick for “Head Up” or “Head Down” and adjust the upper limit position.
3. Press F5 to program a sequence of jobs.
4. Tap desired entry to open keypad. Enter data for each program: length, number of pieces and set Yes to include selected job in queue – tap the area on the right of “Yes/No” than a new window will open (see picture on next page). Select Yes and press “check mark”



PROGRAM	PART NUMBER	LENGHT	N. PIECE	ENABLE
1	101010	2.0000	1	No
2	201010	5.0000	1	No
3	301010	15.0000	5	Yes
4	401010	27.0000	1	No
5	501010	300.0000	2	No



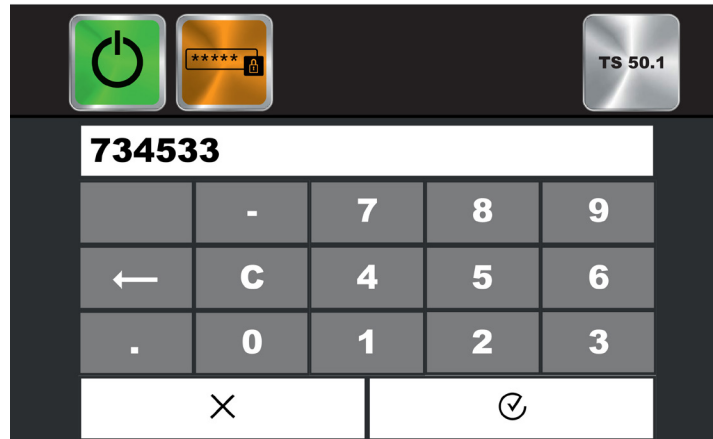

5. Repeat above setup for desired number of jobs. Maximum 10 jobs can be programmed in queue.
6. Press F1 to Reset Queue
7. Press F5 to Reset No. Pieces
8. Tap Save Icon to save the entered data. Press Exit button (back arrow) on the touchscreen to return to the cycle start screen.
9. Manually position the movable guide arm close to the workpiece.
10. Select Flood (F2) or Mist (F4) then "ON" or "Auto" by pressing the button continuously to cycle through the options
11. Set Feed Force and Feed Rate using the dials on the left of the control panel.
12. Set Blade Speed using the blade speed potentiometer.
13. Press F6 to enable the blade & then press F7 to start the blade & cycle. The blade will start and head will descend with set feed rate. Shuttle will move to programmed length and close the shuttle vice. (Note. To start the cycle, head must be in upper position and activate the head up limit switch.)
14. After completion of the cut the blade will turn off and head will move up until the head up limit switch is activated.
15. Front vise will open and shuttle will feed programmed length.
16. Front vise will close, blade will start and head will descend with set feed rate. Shuttle will move to next programmed length.
17. Cycle will repeat until all required pieces are cut and all jobs in queue are completed.
18. To interrupt auto cycle press F8 and to restart auto cycle press F7. If an interrupted cycle is restarted then it will start from the beginning of the cycle. In order to restart the head must be raised to the upper limit. Reset can be pressed to abort the cycle.

Note: In both Job (J) mode and Queue (Q) mode you can enable or disable the trim cut function by holding the FAST/ADVANCE button and pressing the F4 button.

HYDRAULIC FEED CONTROL

The Hydraulic Feed Control is located to the left of the control panel. These controls allow independent control of Feed Force (FF) and Feed Rate (FR)

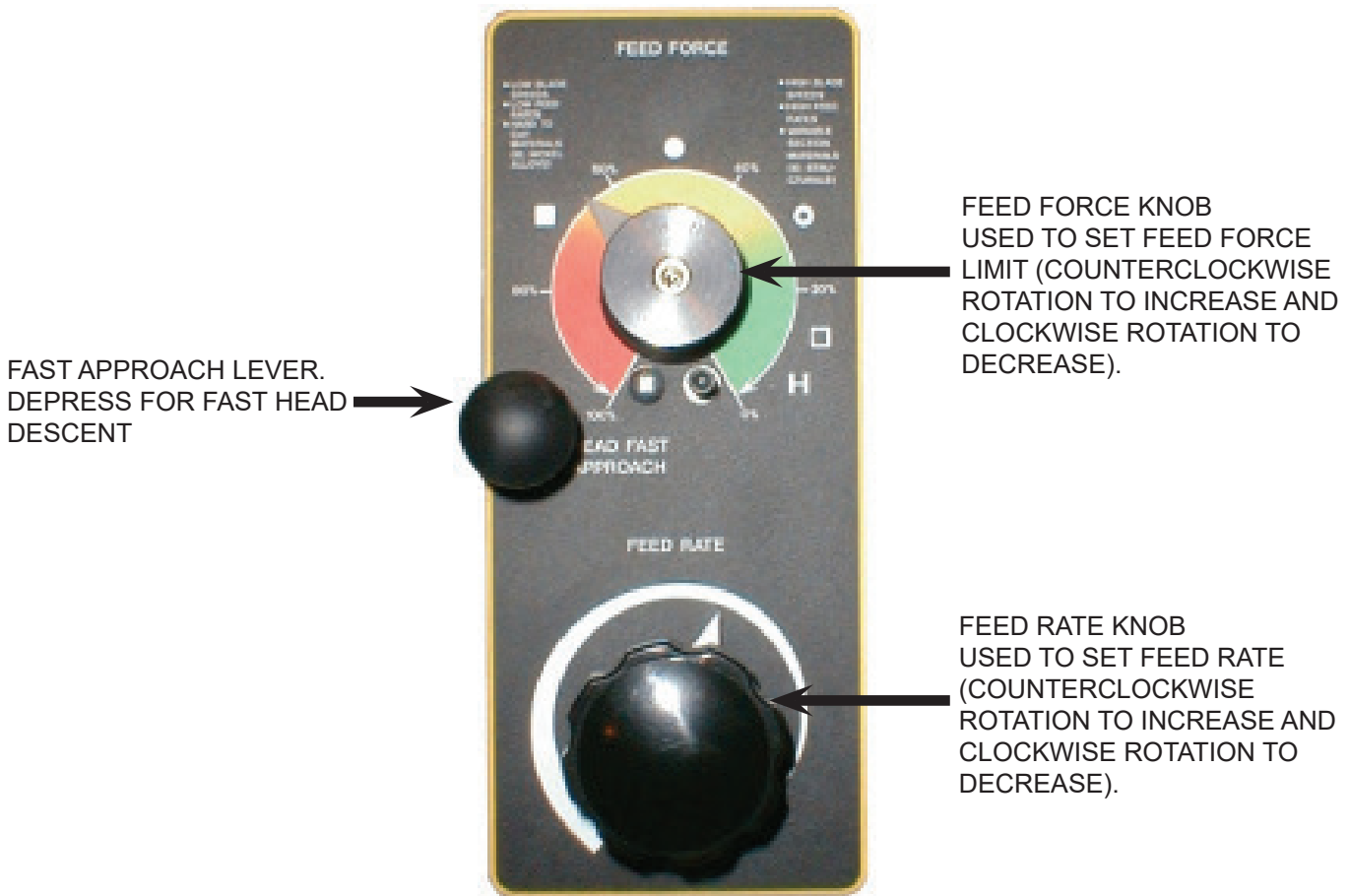

CUTTING PARAMETERS CHART

A full size CUTTING PARAMETERS CHART is mounted on the front of the main electrical panel. The chart contains five steps for the operator to follow in order to achieve optimum performance of the saw. These steps are detailed on the following pages.

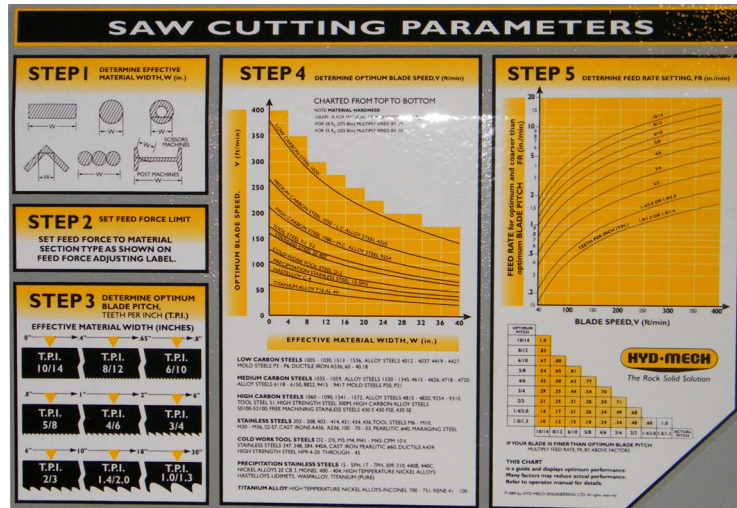

STEP 2: SET FEED FORCE LIMIT

The Feed Force Limit is the maximum amount of force with which the head is allowed to push the blade into the work-piece. (Feed force to be adjusted during head descent)

CUTTING SOLIDS

For cutting solids, the wider the section, the less FF should be set, to avoid blade overloading. See the graph below.

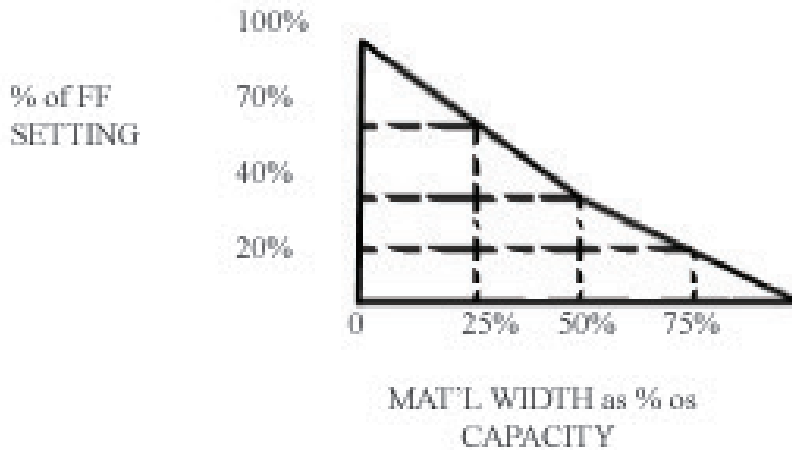

EXAMPLE: When cutting a solid which is 1/2 of machine capacity using the graph, locate 50% on the horizontal line and travel upwards to the plotted line and then travel directly across to the vertical FF Setting line. The point that you have arrived at shows a setting of 40% for a piece 50% of capacity.

CUTTING STRUCTURALS: A reduced Feed Force Setting is used when cutting structurals.

STEP 3: DETERMINE OPTIMUM BLADE PITCH - TEETH PER INCH (T.P.I.)

Selecting a blade with proper tooth pitch is important in order to achieve optimal cutting rates and good blade life.

For cutting narrow or thin wall structural materials a fine blade with many teeth per inch (T.P.I.) is recommended. For wide materials a blade with a coarse pitch should be used. The sketch can be referenced for the blade pitch changes for differing effective material widths.

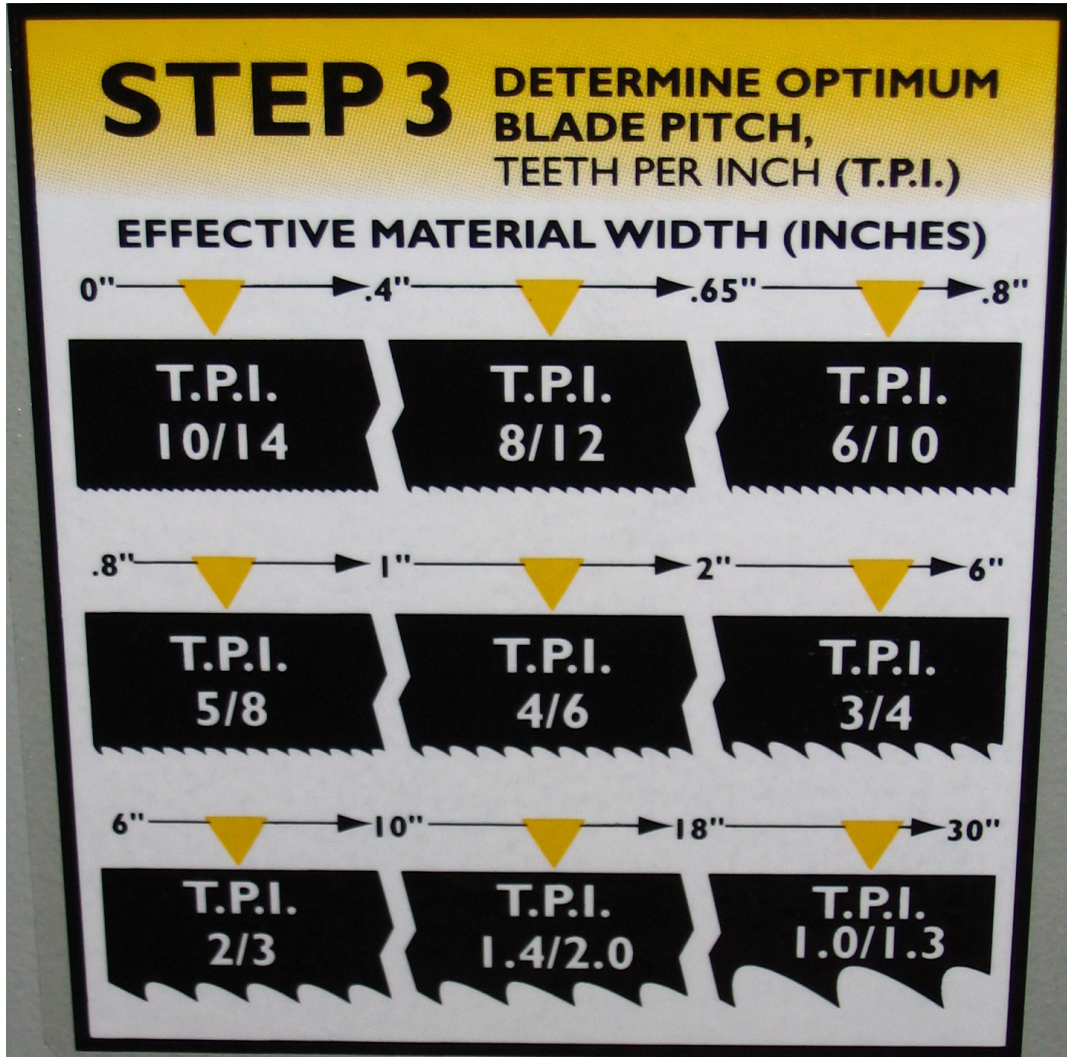

Optimum Blade Pitch (T.P.I) for Material Width (Inches)

It is impractical to change the blade to the proper pitch every time a different width of material is cut and it is not necessary, but remember that the optimum blade will cut most efficiently. Too fine a blade must be fed slower on wide material because the small gullets between the teeth will get packed with chips before they get across and out of the cut. Too coarse a blade must be fed slower because it has fewer teeth cutting and there is a limit to the depth of a cut taken by each tooth. Allowance for the use of a non-optimum blade is made in STEP 5.

Example #1: Effective material width of 8" (200 mm):

Optimum blade has 2/3 teeth per inch.

STEP 4: DETERMINE OPTIMUM BLADE SPEED, V (ft/min) (m/min)

The relationship between optimum blade speed and effective material width for various materials is represented on the graph shown.

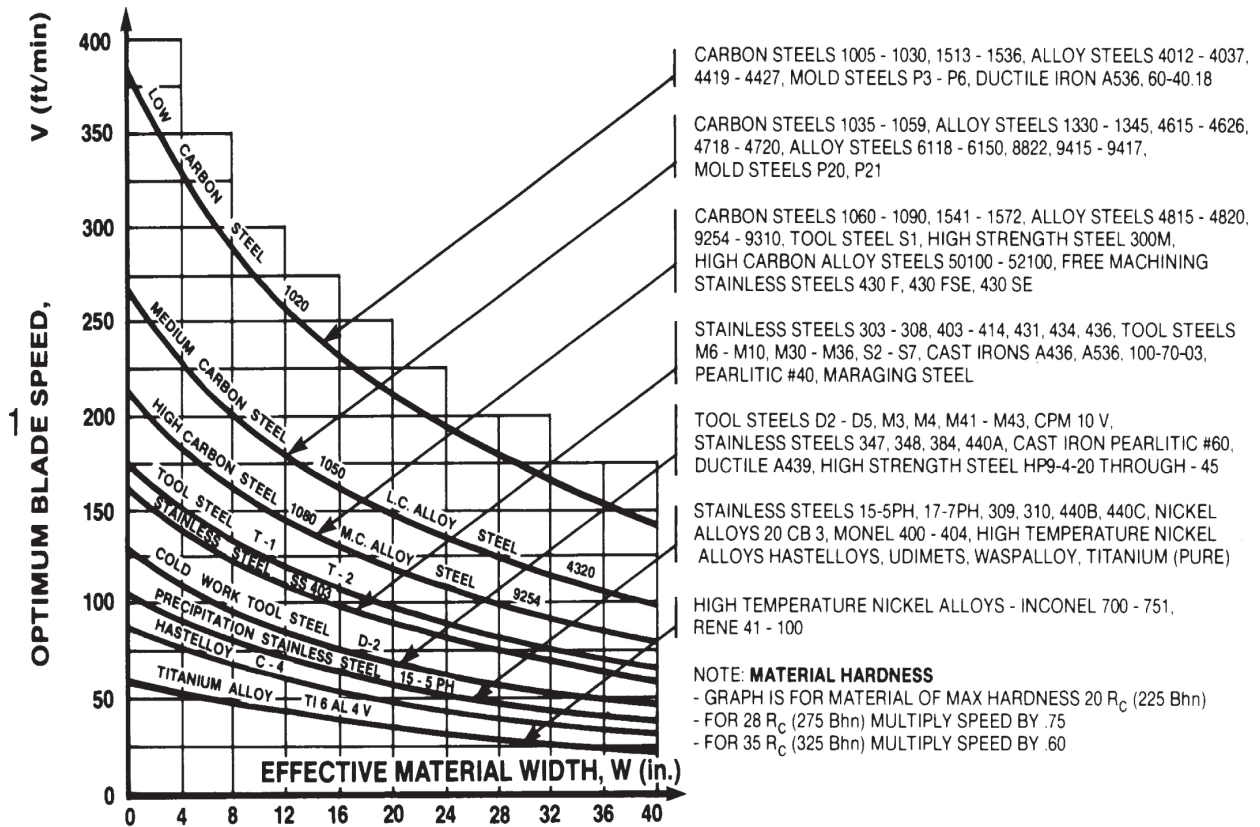

Optimum Blade Speed Curves

The graph shows that as effective material width gets wider or as material gets harder, lower blade speeds are recommended. If material is narrow or soft, higher blades speeds should be selected.

Example #1

1. 8" (200mm) diameter #1045 Medium Carbon Steel solid bar is to be cut.
2. On the graph above find the Medium Carbon Steel Curve which represents the optimum blade speeds for 1045 Carbon Steel.
3. On the horizontal axis (effective material width axis) find number 8 which represents effective material width of an 8" (200mm) diameter solid.
4. Find the point where a vertical line from 8" (200mm) intersects the Medium Carbon Steel Curve.
5. From this intersection point run horizontally left to the vertical axis (optimum blade speed axis) and find the point marked "200".
6. For 8" (200mm) diameter, 1045 Carbon Steel solid bar 200 ft/min (60m/min) is the optimum blade speed.

NOTE:

1. Higher than optimum blade speed will cause rapid blade dulling. Lower than optimum blade speeds reduce cutting rates proportionately and do not result in significantly longer blade life except where there is a vibration problem. If the blade vibrates appreciably at optimum speed as most often occurs with structurals and bundles, a lower blade speed may reduce vibration and prevent premature blade failure.
2. Material Hardness - The graph above illustrates blade speed curves for materials of hardness 20 RC (225 Bhn) or lower. If the material is hardened then the multipliers need to be used. These multipliers are given in the NOTE at the bottom right of the graph. As the hardness increases the optimum blade speed decreases.

The following table gives examples of the optimum blade speeds for different materials.

#	MATERIALS	OPTIMUM	BLADE SPEED
		(ft/min)	(m/min)
1	5" (125mm) Diameter Solid Carbon Steel	225	70
2	12" (300mm) I-Beam	290	90
3	4" x 4" (100mm x 100mm) Rect. Tube 1/4" (6mm) Wall	350	110
4	4" (100mm) 400 Stainless Steel	140	45
5	2" x 2" (50mm x 50mm) Rect. Tube 1/4" (6mm) Wall		
	Bundle 5" x 5" pcs. 10" x 10" (500mm x 500mm)	325	100
6	3" x 3" (75mm x 75mm) Inconel	60	20

Materials and Blade Speed

STEP 5: DETERMINE FEED RATE SETTING, FR (in/min) (mm/min).



FEED RATE is the vertical speed at which the blade descends through the work-piece.

The FEED RATE Knob controls FEED RATE of the blade descent. The FEED RATE should be adjusted only in one direction (from "O" to required value). If you go too far, go back to "O" and come back up. To set FEED RATE for particular cutting situations use the graph below, which represents the relationship between FEED RATE, blade speed and blade pitch.

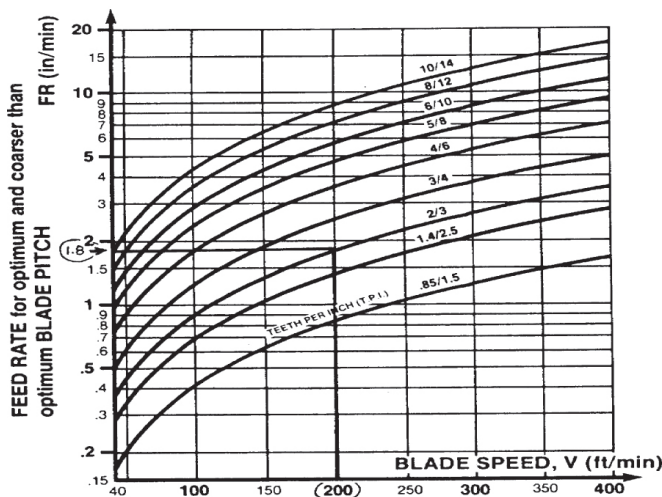

Feed Rate Calculation

Example #1: It is known from Step 3 that optimum blade pitch is 2/3, and from Step 4 that blade speed is 200 ft/min (60mm/min). From the Graph on the left, the FEED RATE is determined in the following way:

1. On the horizontal axis (blade speed axis), find 200 ft/min (60mm/min).
2. Find the point where a vertical line from 200 ft/min (60mm/min) would intersect the 2/3 blade pitch curve
3. From this intersection point run horizontally left to the vertical (FEED RATE) axis, to arrive at 1.8 in/min (45mm/min) FEED RATE. Thus 1.8 in/min (45mm/min) is the FEED RATE for cutting 8" (200mm) diameter 1045 Carbon Steel when the optimum 2/3 pitch blade is used.

FEED RATE, continued

If the saw is fitted with a blade coarser than optimum (e.g.: 1.4/2.5 TPI) we can still use the graph, but we go to the 1.4/2.5 curve. As a result we find that the FEED RATE is decreased to 1.3 in/min (133mm/min) for this blade. If however, the machine is fitted with a finer than optimum blade (e.g. 3/4 TPI) we use the graph for the optimum blade as before, and then use a multiplier given by the table below.

OPTIMUM PITCH											ACTUAL PITCH	
10/14	1.0											
8/12	.83											
6/10	.67	.80										
5/8	.54	.65	.81									
4/6	.42	.50	.63	.77								
3/4	.29	.35	.44	.54	.70							
2/3	.21	.25	.31	.38	.50	.71						
1.4/2.5	.17	.20	.25	.31	.40	.57	.80					
.85/1.5	.10	.12	.15	.18	.24	.34	.48	.60	1.0			
	10/14	8/12	6/10	5/8	4/6	3/4	2/3	1.4/2.5	.85/1.5			

**IF YOUR BLADE IS FINER THAN OPTIMUM BLADE PITCH
MULTIPLY FEED RATE, FR, BY ABOVE FACTORS**

Optimum Vs. Actual Blade Pitch

ADDITIONAL CUTTING SETUP EXAMPLES

EXAMPLE # 2

Material:

Round Steel Tube SAE 4320 - Hardened to 35 RC (325 Bhn)
Dimensions - 6" O.D. x 4" I.D. (150mm O.D. x 100mm I.D.)

- Step 1** Effective Material Width: 4 1/2" (.75 X 6) 114mm (19 x 6)
- Step 2** Feed Force limit setting for 6" Diameter material (Refer to Feed Force Limit, Setting in Step 2)
- Step 3** Optimum blade pitch (TPI): 3/4 T. P. I.
Actual blade pitch on the saw: 4/6 T. P. I.
- Step 4** Optimum blade speed for 4 1/2" effective 225 ft/min (70m/min) material width
Blade speed reduced by hardness factor: 225 ft/min X .60 = 135ft/min (70m/min x .60 = 42m/min)
- Step 5** Feed Rate for 3/4 TPI blade: 1.8 in/min (45mm/min)
Feed Rate for 4/6 TPI blade: 1.8 in/min X .70 = 1.3in/min
(reduced by finer than optimum blade pitch factor) (45mm/min x .70= 31.5mm/min)

SECTION 3 – MAINTENANCE & TROUBLESHOOTING

SAFETY DURING MAINTENANCE AND TROUBLESHOOTING

“Lock-out”, or “Lock-out Tag-out” are terms that refer to procedures taken to prevent the unexpected start-up, or other release of energy, by a machine, whenever anyone is required to remove or bypass safety guards or devices, or whenever anyone is required to place part of his body in a hazard area.

In almost all jurisdictions, it is required that owners of industrial equipment establish and post lock-out procedures. Know and use the lock-out procedures of your company or organization. In the absence, of such posted procedures, use the following procedure.

LOCK OUT PROCEDURE

Whenever work is to be performed on a machine, which requires removal or bypassing of safety guards or devices, or the placement of part of anyone’s body in a hazard area, the following steps shall be taken:

1. Operator shuts down the machine.
2. The supervisor in charge of the machine must be informed of the intention to Lock-out the machine.
3. The FEEDER power which supplies power to the machine and which is connected to the machine via the Power Junction Box (see picture below) must be turned OFF and locked in the OFF (0) position by means of a padlock. The key for this padlock must be kept by the person performing the work on the machine. If more than one person is performing work on the machine, then a multiple lock hasp shall be used, and each person shall apply his or her own lock to the hasp.
4. The Machine Power Disconnect Switch must be turned OFF, and locked in the OFF (0) position by means of a padlock. The key for this padlock must be kept by the person performing the work on the machine. If more than one person is performing work on the machine, then a multiple lock hasp shall be used, and each person shall apply his or her own lock to the hasp.
5. Prior to starting any work on the locked-out machine, the supervisor shall attempt to start the machine to ensure that the lock-out device provides adequate protection. Operating controls must be reset to the “OFF” position after this test.
6. Work on the locked-out machine may now proceed.

S20A Machine disconnect switch used for safety lockout purposes.



Special door lock.



Power Junction Box.

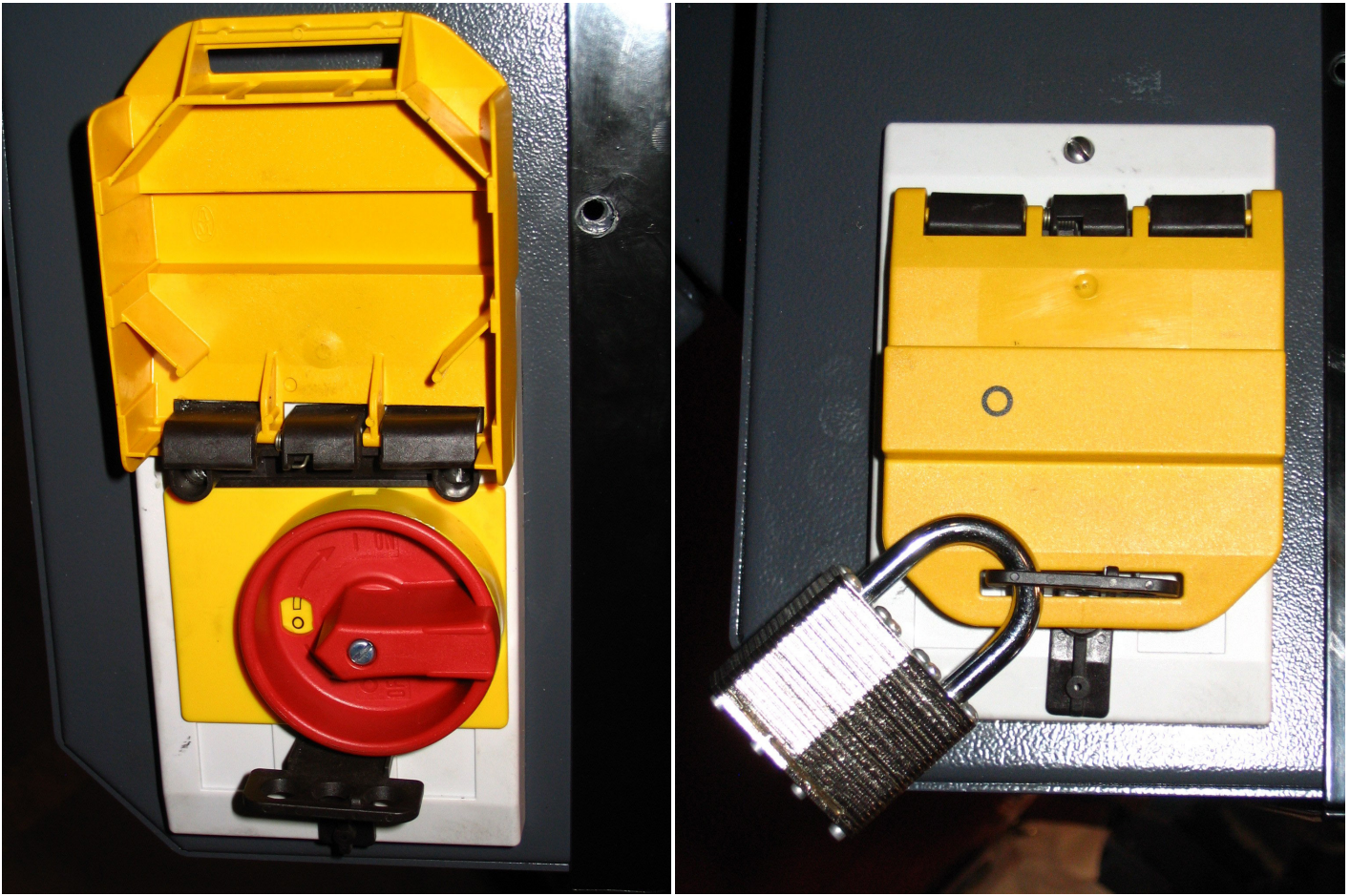

Machine Power Disconnect located on the side of the machine control box.

1. Ensure switch is in the OFF position.
2. Close the disconnect switch cover.
3. Install padlock and lock it.

RESTORING MACHINE TO USE

After completion of all repairs or maintenance to the locked-out machine, it shall be restored to use as follows:

The person(s) who performed the work shall verify that all areas around the machine are safe, before the machine is re-energized. No-one shall be permitted in un-safe areas around the machine. All guards and covers shall be properly installed.

Each lock-out padlock shall be removed by the person who applied it.

After the lock-out padlocks are removed, and before the machine is started, the supervisor and all other employees who use the machine, shall be informed that the lock-out has been removed. After notification is made, the machine may be re-started.

BLADE CHANGING PROCEDURE

NOTE: Wear gloves for protection from the sharp blade.

1. Open the Wheels door by unscrewing the two knobs.

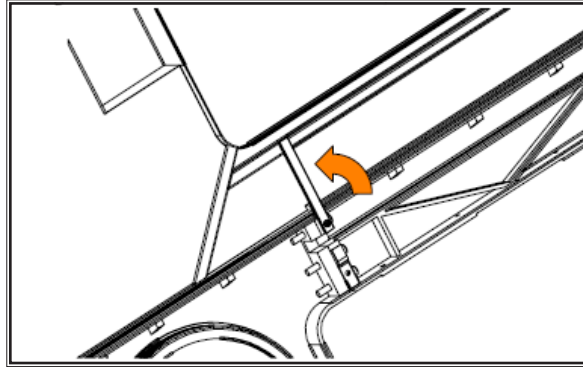

2. Loosen the Blade Tensioner by turning counter clockwise.

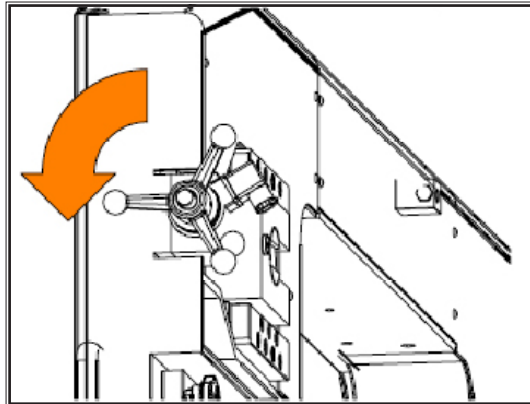

3. Open the blade guard at idler guide arm by undoing the mounting screws and removing it as illustrated below.

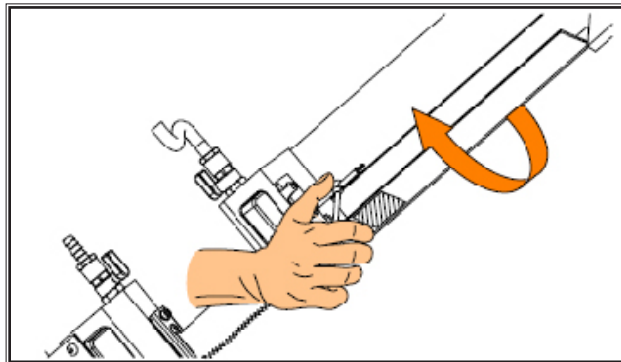

-
4. Remove the worn blade by sliding it off the wheels and out off both guide blocks

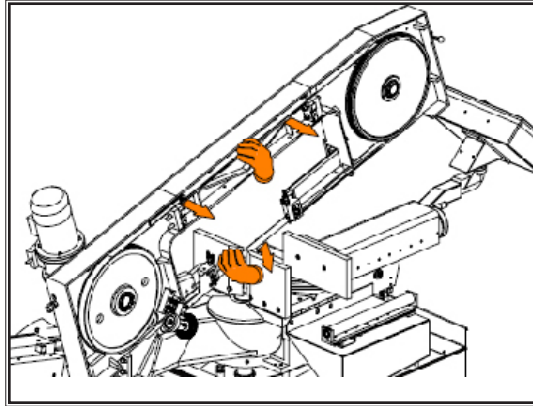

5. Your new blade will be in a coil. While wearing gloves, hold the blade away from yourself; twist the blade to uncoil it. Do not let the blade teeth bounce on the concrete floor as some damage may be caused.
6. Place the new blade in the carbide guides and then slide the blade over the wheels. The teeth should be pointing towards the drive side as they pass through the carbide guides.
7. Make sure there is a small amount of play between the blade and guide carbides. The blade band should be snug but able to move freely up and down.

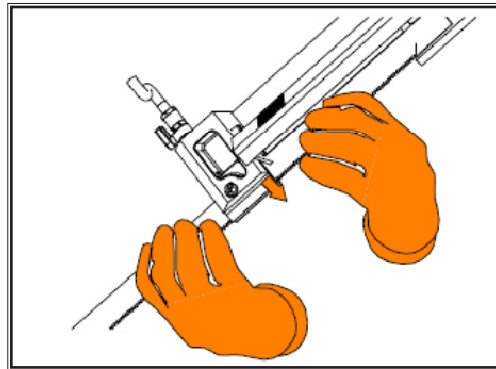

8. If the amount of play is not sufficient for the blade to run smoothly, adjust the locking torque of the screws with an Allen key.

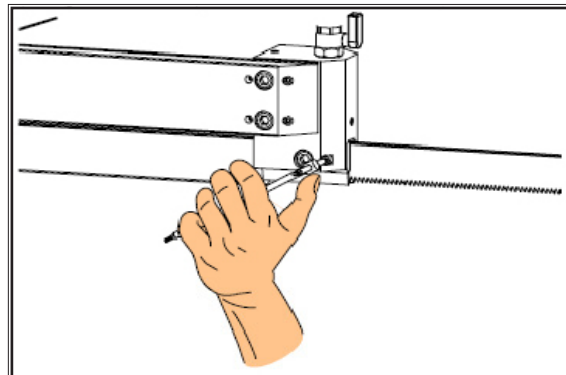

-
9. With the blade in place, turn the tensioner handle clockwise until Blade Tension Display shows required value. Recommended blade tension is between 1000 - 1200 kg. (2200 - 2650 lbs) If blade is under tensioned the blade motor will not start.
 10. Replace the blade cover and close wheels door.
 11. Jog the blade a few rotations to check that the blade is not moving in or out on the blade wheels. As the blade tracking will stay fairly constant, it should be checked occasionally by measuring the gap between the back of the blade and wheel flange. The gap should measure .040-.080". If the tracking requires adjustment, follow the instructions below.

BLADE TRACKING ADJUSTMENT

First, inspect the blade wheels for wear or damage and repair as required, Blade tracking adjustment should always begin at the wheel where the tracking is farthest out of specification. Using the instructions below, adjust the worst wheel, jog the blade and recheck both wheels. Repeat this process until both wheels are within specification.

Idler Wheel Adjustment

The Idler Wheel must be adjusted so that it is aligned with the drive wheel. The purpose of the adjustment is to ensure that the back of the blade remains about .040-.080" away from the wheel flange during rotation.

1. Release blade tension.
2. Open wheel cover.

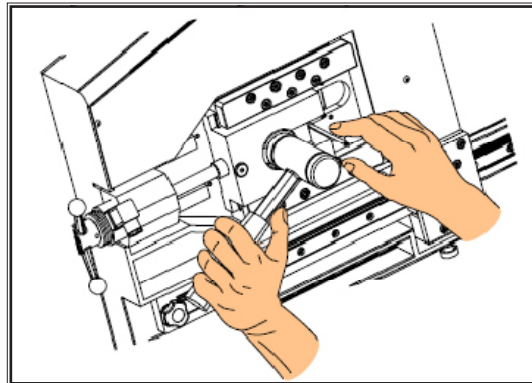

3. Loosen the screw and using a mallet tap the shaft in or out.
4. Restore the machine and run blade for few wheel rotations.
5. Check the distance between the blade and wheels flange.
6. If necessary repeat above steps until proper gap is achieved.

DRIVE WHEEL ADJUSTMENT

The Drive Wheel adjustment is closely linked to adjustment of the Idler Wheel. The purpose of the adjustment is to ensure that the back of the blade remains about .040-.080" away from the wheel flange during rotation.

1. Open wheel cover.
2. Loosen all the screws on the wheel and manually move it in or out until the blade is correctly distanced from the wheel flange.

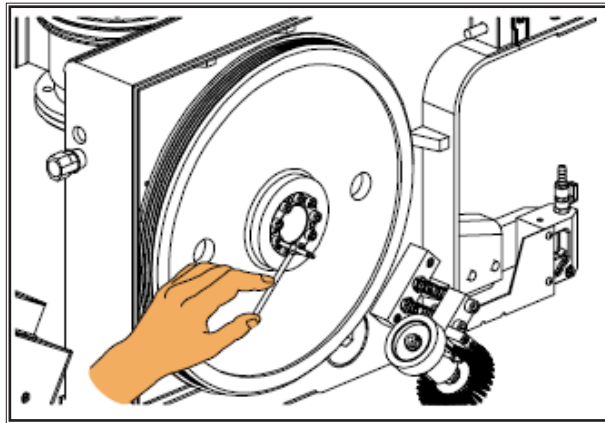

3. Restore the machine and run blade for few wheel rotations.
4. Check the distance between the blade and wheel's flange.
5. If necessary repeat steps until proper gap is achieved.

BLADE GUIDE ADJUSTMENT

At the bottom of the guide arms are the blade guide block assemblies with carbide pads. These assemblies will need to be adjusted occasionally as the carbide pads become worn, or if a blade with different thickness is used. To adjust properly, follow this simple procedure.

1. Make sure there is a small amount of play between the blade and guide carbides. The blade band should be snug but able to move freely up and down.
2. If the amount of play is not sufficient for the blade to run smoothly, adjust the locking torque of the screws with an Allen key.

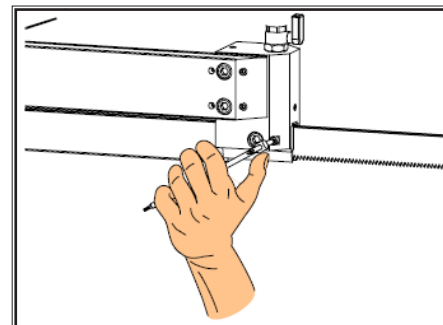
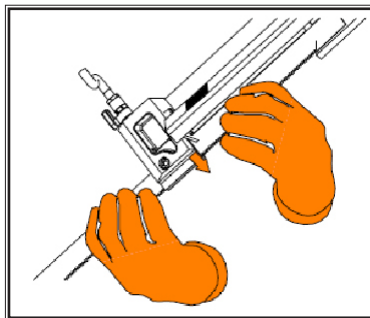

CARBIDE REPLACEMENT

The blade guide blocks are equipped with one top carbide and two side carbide inserts each. The working life of carbide guides is practically the same as that of the machine itself. However, if required they can be replaced by removing the plate fixing screw as shown.

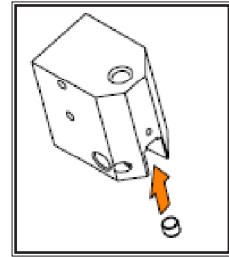
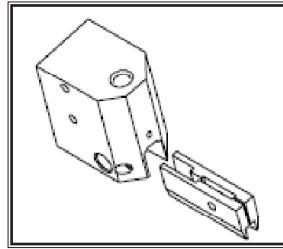
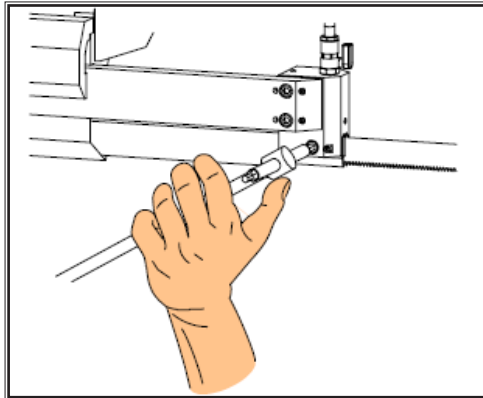

The top carbide is press fit into the guide block. If the top carbide needs replacement the whole guide block has to be changed.

BLADE BRUSH ADJUSTMENT

The machine leaves the factory with the blade brush adjusted for maximum life of the brush. This setting places the ends of the blade brush wires so as to contact the blade at the bottom of the blade gullets. The plastic drive wheel that is driven by the drive wheel face should be held against the wheel face with the minimum force that is necessary to ensure brush rotation. As the blade brush wears it is necessary to periodically adjust it closer to the blade or if a new brush is installed, further away from the blade.

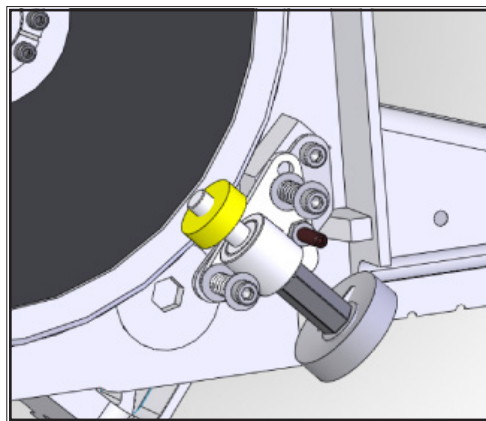

As shown, there are two springs on socket head screws holding the brush assembly against the blade. There is also an adjusting stop socket set screw **A** with a hex nut **C** on it. This adjusting set screw works as a stop determining the brush position in respect to the blade. To move the brush closer to the blade loosen the hex nut and turn the setscrew **A** counter clockwise with an Allen key. Then rotate the brush stem towards the blade and turn the spring loaded socket head bolts **B** in to maintain proper spring preload. To move the brush away from the blade loosen the spring loaded socket bolts **B** respectively. Then rotate the brush stem away from the blade and turn setscrew **A** clockwise to lock the brush in position. Lock the hex nut to prevent the set screw from loosening.

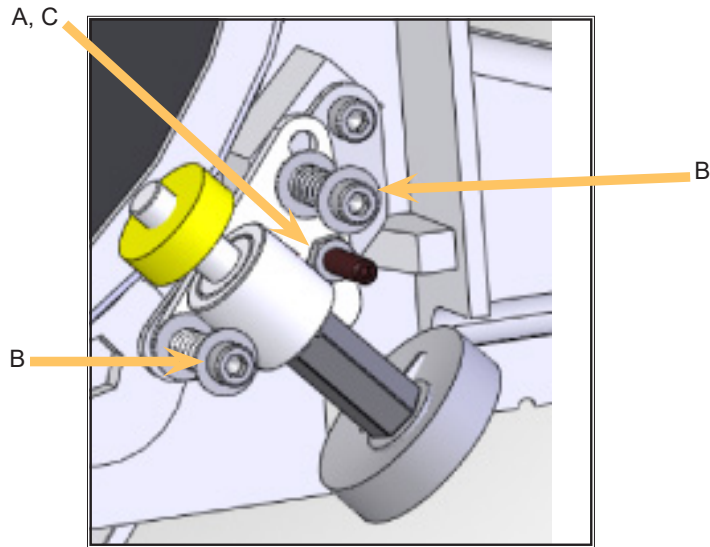

ANGLE BRAKE ADJUSTMENT

The clamping force on the swivel brake can be adjusted to ensure that the Head is held securely and does not move during cutting. The brake handle should be adjusted so that it does not “bottom out” or hit its movement limit, yet holds the head securely.

ANGLE BRAKE ADJUSTMENT PROCEDURE

STEP 1 Release the brake handle.

STEP 2 Loosen the nut “A”.

STEP 3 Adjust the set screw “B” until the swivel brake pad “C” contacts the table.

STEP 4 Tighten the nut “A”.

STEP 5 Push the brake handle down to lock the head. Try to swing the head to make sure the brake holds the head firmly in place.

Repeat the steps if necessary.

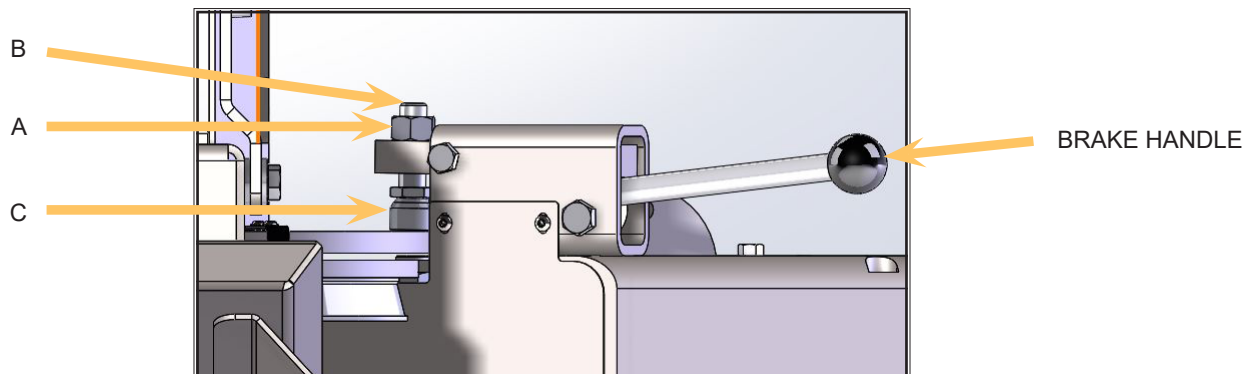

BLADE TENSION SLIDE ADJUSTMENT

To reduce the play, which may develop over time between the blade tensioner slide and slide gibs, adjust the screws between the gibs and slide as follows:

1. Remove the head front cover.
2. Undo blade tension.
3. Remove blade from wheels.
4. Remove the pin connecting tensioner actuator with slider.
5. Move the slider by hand back and forth to locate any friction or excessive play.
6. Loosen the nuts, using tubular nut driver while holding the set screws firm with Allen key.
7. Tighten the set screws to take up any play or loosen them up in case of excessive friction.
8. Retighten the nuts with tubular nut drive.

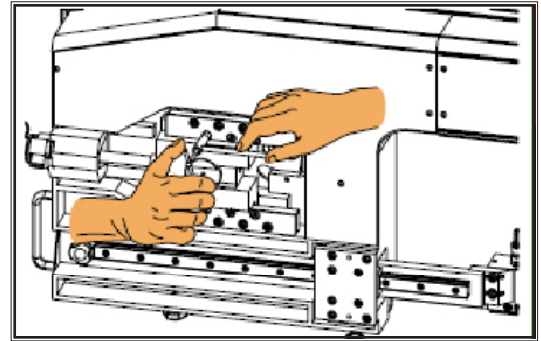

90 AND 30 DEGREE STOP ADJUSTMENT

There are two adjustable mechanical stops for 90 degree and 30 degree head swing position that can be recalibrated if required.

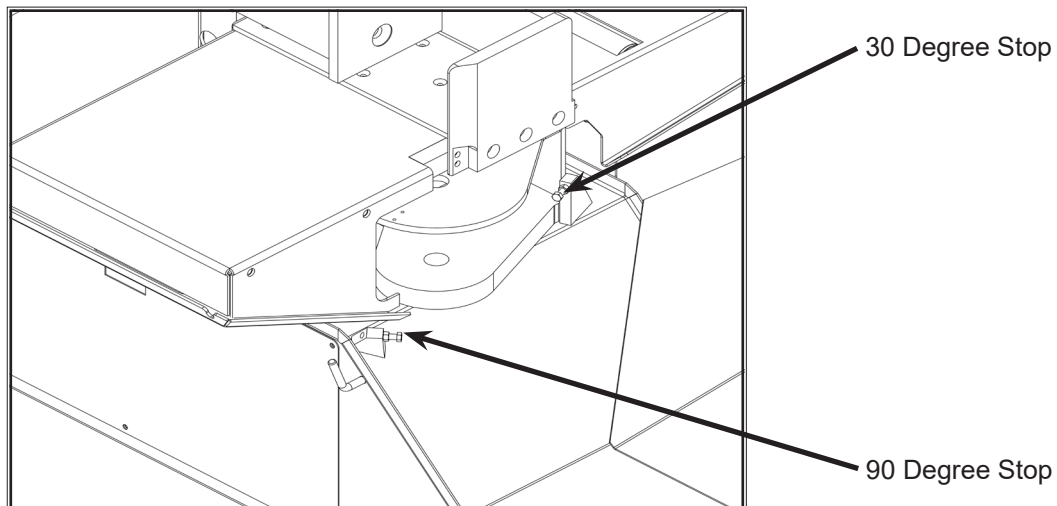

LUBRICATION

The S20A was designed to minimize the maintenance requirements. Moving assemblies and contact faces need lubrication on a regular schedule whether they are in heavy use or not. The lubrication requirements of the S20A are primarily the saw pivot points and shuttle assembly which are equipped with grease fittings, and metal to metal surfaces that require lubrication to prevent wear and seizure.

It is recommended to use LPS ThermaPex Hi-Load bearing Grease manufactured by LPS Laboratories or equivalent, for lubrication of the shuttle assembly. For other points of lubrication general purpose grease is sufficient.

The lubricant should be applied as frequently as required. Main lubrication points are indicated on the following pictures.

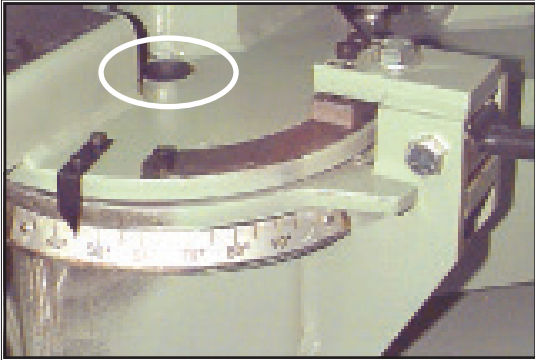

Swivel Pivot

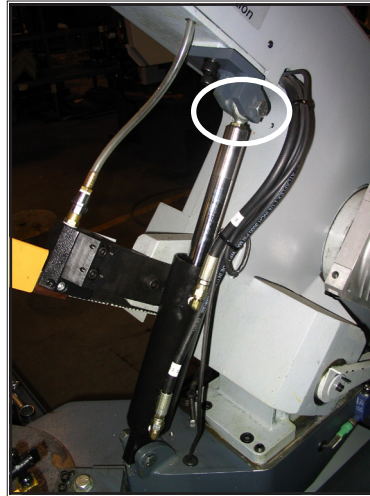

Head Cylinder Rod End



Runner Block
Movable Guide Arm

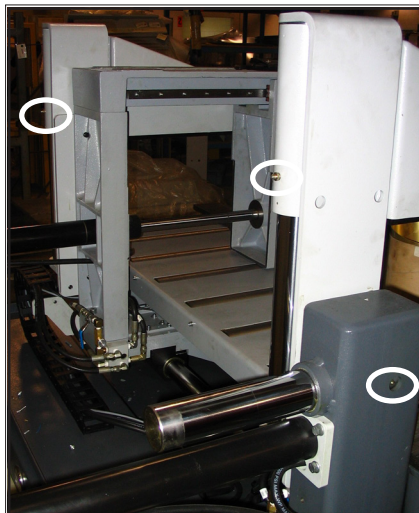

Vise/Bundling

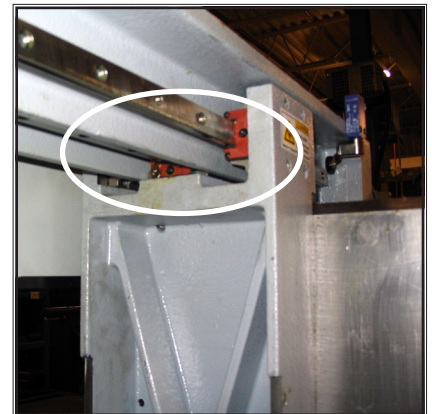

Runner Block
Shuttle Jaw (3)

GEARBOX LUBRICATION

The Bonfiglioli W86 gearbox used on the S20A is supplied with 0.64 litres (0.17 US gallons) of Shell Omala S4 WE 320 synthetic oil. This oil has an ISO Viscosity Grade of 320 that is optimum for ambient temperatures from 20-70 Deg C (70-140 Deg F). The W86 was designed to be a sealed unit, so no oil change should be necessary. However, if the oil needs to be changed, Bonfiglioli recommends that, should a lubricant other than the approved Shell type be used, this be equivalent viscosity wise and of the synthetic type. The lubricant must also have the necessary EP and anti-foaming additives.

HYDRAULIC MAINTENANCE

1. HYDRAULIC OIL- Machine hydraulic reservoir is filled with mineral oil AW 46. In case of changing the brand, hydraulic system should be drained and thoroughly flushed. Following is a list of recommended replacement oils:

- Texaco Rando HD 46
- CHEVRON ECO Hydraulic oil AW ISO 46
- MOBIL DTE 25
- ESSO NUTO H46
- SHELL TELLUS OIL 46

2. HYDRAULIC OIL LEVEL

- Units equipped with sight glass: Oil level should be maintained in the middle of the side glass window.
- Units without sight glass: Filler cap is equipped with dip stick for checking oil level. Oil level should be maintained so the oil leaves a wet trace approximately half way on the dip stick.

3. HYDRAULIC OIL CHANGE - It is recommended to change oil after every 2000 hours of operation but at least once a year.

4. HYDRAULIC PRESSURE - Hydraulic pressure is factory set to 30 bar (440 PSI) and should not require any further attention. System pressure adjustment is located directly on the hydraulic pump.

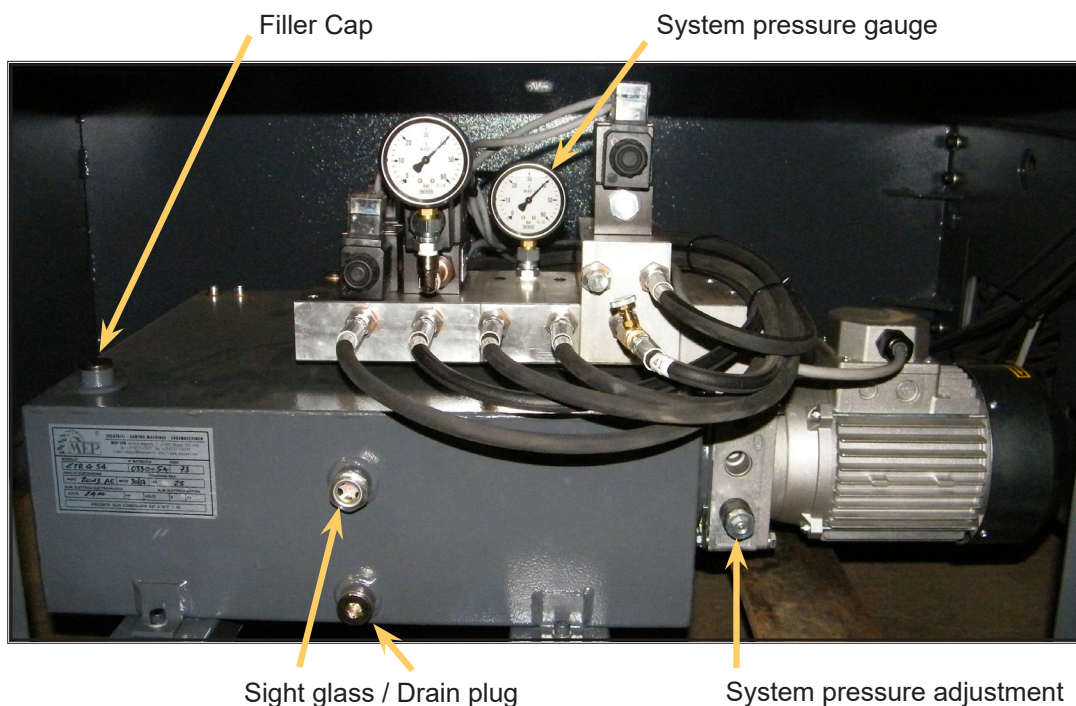

CLEANLINESS

The heavy-duty design should endure heavy operating conditions and provide the customer with flawless machine performance. To extend good performance some care is required especially where cleanliness is concerned.

The following areas should be kept clean:

- Control console free of dirt and grease
- Door charts free of dirt and grease
- Wheel boxes free of chips
- Blade guides free of chips
- Out-feed tables free of chips
- A large chip build-up should be avoided in the base of the saw

NOTE: All parts must be cleaned before any repair service may be performed on them.

TROUBLESHOOTING

LENGTH INACCURACIES

POSSIBLE CAUSES:

1. Coupling loose between screw and stepper motor.
2. Bad stepper motor drive
3. Faulty unit (not repairable in the field) Contact HYDMECH service department.
4. Improper Programmed Information:
 - Length compensation
 - Existing parameter(s) incorrect
 - Incorrect blade kerf

GENERAL RULES – Normally, three types of length inaccuracies may occur

1. Inconsistent – lengths cut are not consistent, error changes. It doesn't matter how long the part required is the error is never the same.
Cause – most likely a drag or slippage between the vises and the material.
2. Consistent – lengths cut are consistent and the error is also consistent. The error always stays the same regardless of part length.
Cause – kerf value or backlash in the ball screw assembly
3. Linear – lengths cut are consistent but the error increases as the part length increases. The longer the part the greater the error.
Cause –incorrect LENGTH and OFFSET values entered in the setup section of the parameters.

DIAGNOSIS:

Check and record existing parameter. Also check for proper blade kerf. By making a cut partway into a piece of material and measuring the width of the cut, the operator can verify blade kerf.

MACHINE ALARMS

- AL1: Emergency: one or more errors occurred:
- AL6: Emergency push button or emergency unit engaged:
these alarms are usually displayed at startup, when emergency push button is pressed or safety relay activated.
- AL12: Safety blade cover open:
blade guard is opened.
- AL16: Forward software limit switch above start position:
this alarm is displayed usually in Manual mode when starting a cut with the head not engaging upper limit switch.
- AL21: Out of stock:
this alarm is displayed when the machine runs out of material.

WARNINGS

- WR8: Check cut start conditions:
this alarm is displayed when pieces the required are equal to the pieces cut in Automatic Mode
- WR13: Jog without homing:
attempt to move the shuttle in Manual Mode without homing shuttle.
- WR15: End of cuts:
all pieces to be cut are completed in job mode.
- WR16: End of queue:
all jobs in queue are completed.

SECTION 4 - ELECTRICAL

ELECTRICAL SCHEMATICS: SEE PDF ON ATTACHED USB

SECTION 5 - HYDRAULIC

**HYDRAULIC SCHEMATICS & PLUMBING DIAGRAMS: SEE PDF
ON ATTACHED USB**

SECTION 6 - MECHANICAL ASSEMBLIES

**MECHANICAL ASSEMBLY DRAWINGS & PARTS LIST: SEE PDF
ON ATTACHED USB**

SECTION 7 - OPTIONS

OPTIONAL ASSEMBLY DRAWINGS: SEE PDF ON ATTACHED USB

SECTION 8 - SPECIFICATIONS

S20A BANDSAW SPECIFICATION LIST

Capacity - 90°	Rectangular	13" (330mm) high x 18" (457mm) wide
	Round	13" (330mm) dia
Capacity - 45°	Rectangular	13" (330mm) high x 10.9" (277mm) wide
	Round	12" (305mm) dia
Capacity - 60°	Rectangular	13" (330mm) high x 7.3" (185mm) wide
	Round	8" (203mm) dia
Blade	Length	14'10" (4521mm)
	Width	1" (25mm)
	Thickness	.035" (0.9mm)
Blade Tension	Manual	Min. = 2200 lbs. (1000kg) Max. = 2650 lbs. (1200kg)
Blade Speed	Variable Frequency Drive	75-350 surface feet/min (23-105 surface m/min)
Blade Guides	Pre Set carbide inserts	
Blade Wheel Diameter	17 3/4" (451 mm)	
Drive	Blade drive: 5 hp (3.7 kW)	
	Hydraulic drive: 1.5 hp (1.1 kW)	
Hydraulic System	440 psi (30 bar)	
Hydraulic Tank Capacity	4.75 U.S. Gallons (18 L)	
Coolant Tank	6 U.S. Gallons (22.7 L)	
Shuttle Stroke	29" (736mm)	
Table Height	31" (787mm)	
Machine Work Load	5000 lbs (2268kg)	
Machine Weight	3600 lbs (1633kg)	
Dimensions	89.5" (2273mm) Wide x 86.75" (2203mm) Long x 55" (1397mm) High	
Options	Full capacity bundling	
	Variable vise pressure	
	Material stop	

S20A LAYOUT DRAWING

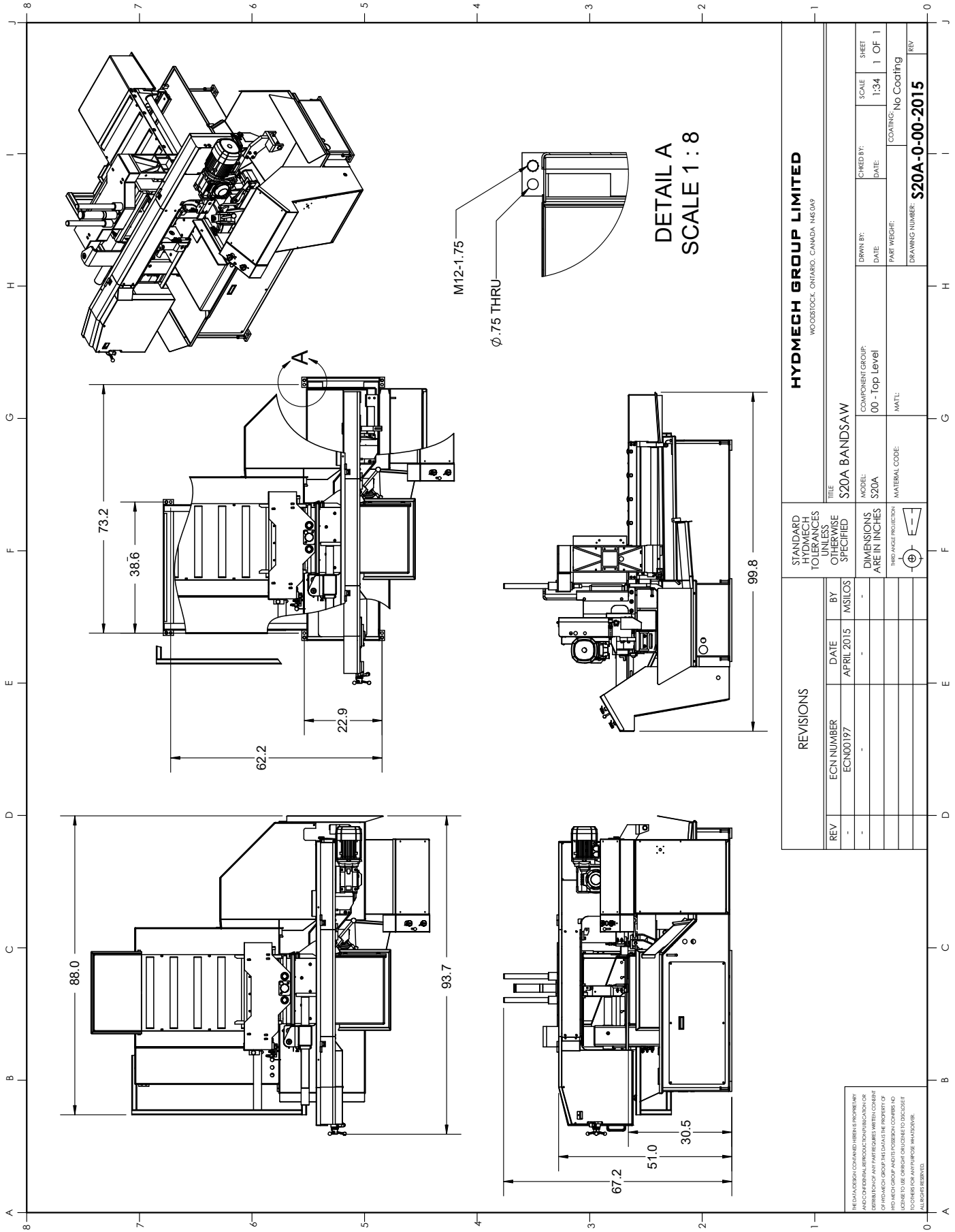

DETAIL A
SCALE 1:8

HYDMECH GROUP LIMITED
WOODSTOCK, ONTARIO, CANADA N4S 0A9

STANDARD HYDMECH TOOLS UNLESS OTHERWISE SPECIFIED		TITLE	
REV	ECN NUMBER	DATE	BY
-	ECN00197	APRIL 2015	MS/LOS
DIMENSIONS ARE IN INCHES		MODEL: S20A	
THIRD ANGLE PROJECTION		COMPONENT GROUP: 00 - Top Level	
MATERIAL CODE:		DATE:	
MATERIAL:		DRAWN BY:	
MATERIAL CODE:		DATE:	
MATERIAL:		CHECKED BY:	
MATERIAL CODE:		DATE:	
MATERIAL:		SCALE: 1:34	
MATERIAL CODE:		SHEET: 1 OF 1	
MATERIAL:		DRAWING NUMBER: S20A-0-00-2015	
MATERIAL CODE:		COATING: No Coating	
MATERIAL:		REV:	

THE DATA DESIGN CONTAINED HEREIN IS PROPRIETARY AND CONFIDENTIAL. REPRODUCTION, DISTRIBUTION, OR ANY PART THEREOF WITHOUT THE WRITTEN CONSENT OF HYDMECH GROUP LIMITED IS STRICTLY PROHIBITED. ALL RIGHTS RESERVED.

SECTION 9 - WARRANTY

WARRANTY

HYDMECH warrants parts/components on each new S20A bandsaw to be free from failure resulting from defective material and workmanship under proper use and service for a period of two years on following the date of shipment from the factory. HYDMECH's sole obligation under this warranty is limited to the repair or replacement without charge, at HYDMECH's factory, warehouse, or approved repair shop any part or parts which HYDMECH's inspection shall disclose to be defective. Return freight must be prepaid by the user.

This warranty, in its entirety, does not cover maintenance items, including but not limited to lubricating grease and oils, filters, V-belts, saw blades, etc., nor any items therein which show signs of neglect, overloading, abuse, accident, inadequate maintenance, or unauthorized altering.

MOTOR, GEARBOX, PUMP, ELECTRIC COMPONENTS, VALVES, HOSES, FITTINGS, and any other items used in the manufacture of the S20A, but not originally manufactured by HYDMECH are subject to the original manufacturer's warranty. HYDMECH will provide such assistance and information as is necessary and available to facilitate the user's claim to such other manufacturer.

Liability or obligation on the part of HYDMECH for damages, whether general, special or for negligence and expressly including any incidental and consequential damages is hereby disclaimed. HYDMECH's obligation to repair or replace shall be the limit of its liability under this warranty and the sole and exclusive right and remedy of the user.

THIS WARRANTY IS EXPRESSLY IN LIEU OF ALL OTHER WARRANTIES, EXPRESSED OR IMPLIED, WRITTEN OR ORAL, INCLUDING WITHOUT LIMITATION ANY IMPLIED WARRANTIES OF MERCHANTABILITY OR FITNESS FOR A PARTICULAR PURPOSE.

This warranty may not be changed, altered, or modified in any way except in writing by HYDMECH.

HYDMECH CANADA Corp.
1079 Parkinson Road
P.O. BOX 1659
Woodstock, Ontario
N4S 0A9
Phone: (519) 539-6341
Fax: (519) 539-5126
Toll Free: (877) 276-SAWS (7297)
E-mail: info@hydmech.com